

Technical Comparison Guide: Praseodymium Bromide Hydrate vs. Praseodymium Chloride Hydrate Solubility

Author: BenchChem Technical Support Team. **Date:** May 2026

Compound of Interest

Compound Name: Praseodymium bromide hydrate

Cat. No.: B15088958

[Get Quote](#)

Executive Summary

For researchers and drug development professionals, the choice between **Praseodymium Bromide Hydrate** (

) and Praseodymium Chloride Hydrate (

) often hinges on specific solvation kinetics and anion compatibility rather than gross solubility differences.

While Praseodymium Chloride Hydrate is the industry-standard precursor with a well-documented solubility of 104.0 g/100 mL (13°C), **Praseodymium Bromide Hydrate** exhibits characteristics of high solubility consistent with heavy lanthanide halides, though it is often kinetically slower to dissolve from anhydrous forms. This guide dissects the thermodynamic drivers of these properties and provides a validated protocol for precise solubility determination in non-standard solvents.

Physicochemical Profile Comparison

The solubility differences between these two compounds are rooted in their crystal lattice energies and the hydration enthalpy of their respective anions.

Feature	Praseodymium Chloride Hydrate	Praseodymium Bromide Hydrate
Formula	(Common)	(Typically)
Molecular Weight	373.37 g/mol (Heptahydrate)	~380–440 g/mol (varies by hydration)
Appearance	Green, blocky crystals	Green, crystalline solid
Hygroscopicity	Deliquescent (Absorbs moisture until liquid)	Hygroscopic (Absorbs moisture readily)
Solubility (Water)	104.0 g/100 mL (13°C) [1]	High (Thermodynamically favored, >50 g/100 mL est.) [1]
Solubility (Ethanol)	Soluble (Forms alcoholates)	Soluble (High solubility in polar solvents)
Anion Character	Harder Base (Cl ⁻)	Softer Base (Br ⁻)
Lattice Energy	Higher (Stronger ionic attraction)	Lower (Weaker attraction, easier to disrupt)

Key Insight: While the chloride has higher lattice energy, the chloride ion also has a higher hydration enthalpy. The bromide has a lower lattice energy (easier to break), but the bromide ion's hydration is less exothermic. The balance usually favors high solubility for both, but the chloride is more prone to rapid deliquescence.

Solubility Dynamics: The Mechanism

To understand why these compounds behave differently, we must look at the thermodynamic cycle of dissolution.

Thermodynamic Drivers

- Lattice Dissociation (+): Energy required to break the crystal lattice.
 - requires more energy to break than due to the smaller ionic radius of (181 pm) vs (196 pm).
- Hydration (-): Energy released when ions interact with water.
 - releases more energy upon hydration than .

The Result:

- PrCl₃: High Lattice Energy is compensated by High Hydration Enthalpy
Very High Solubility.
- PrBr₃: Lower Lattice Energy is compensated by Moderate Hydration Enthalpy
High Solubility (often comparable to or exceeding chloride in organic solvents due to "softer" character).

Diagram: Solvation Mechanism

The following diagram illustrates the competitive forces during the dissolution of Praseodymium halides.

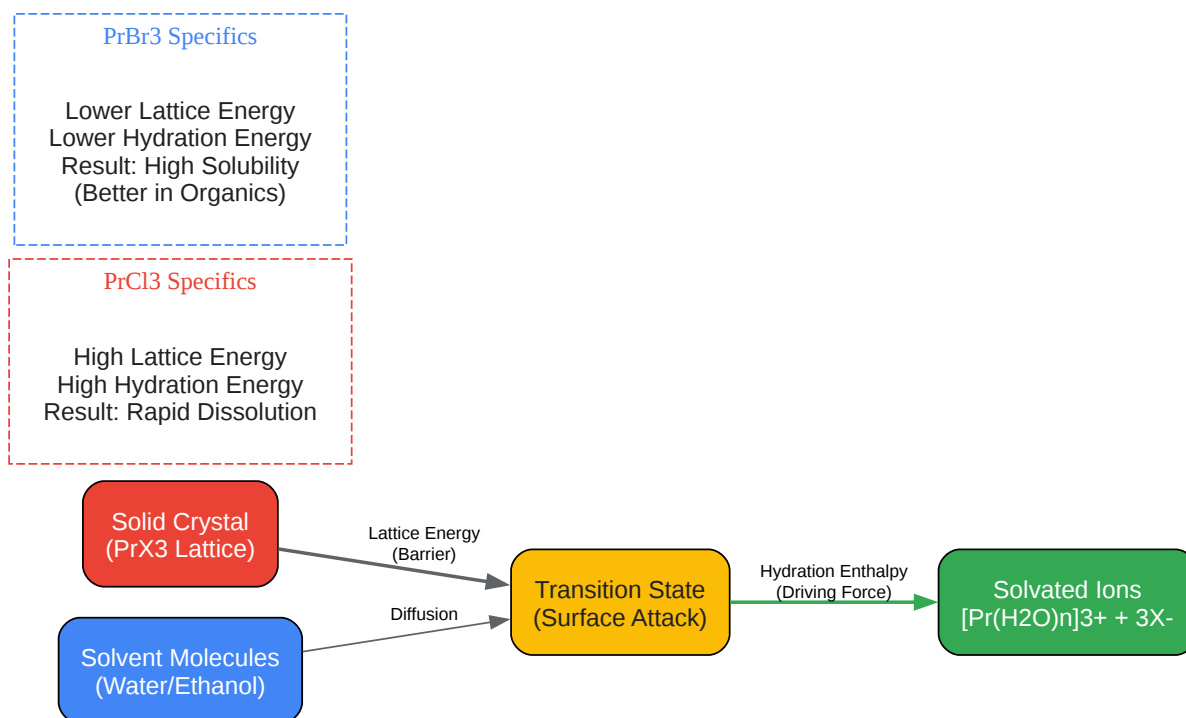

[Click to download full resolution via product page](#)

Figure 1: Thermodynamic cycle of dissolution comparing the energetic barriers and driving forces for Chloride vs. Bromide salts.

Validated Experimental Protocol: Comparative Solubility Determination

Trustworthiness: This protocol uses a Gravimetric Saturation Method, which is self-validating because it relies on mass balance rather than optical detection (which can be skewed by the color of Praseodymium ions).

Materials

- Analytical Balance (± 0.1 mg precision)
- Temperature-controlled water bath ($25.0^{\circ}\text{C} \pm 0.1^{\circ}\text{C}$)
- $0.22\ \mu\text{m}$ Syringe Filters (PTFE for organics, PES for water)
- Weighing dishes (pre-dried)

Step-by-Step Methodology

- Preparation of Supersaturated Solution:
 - Add excess Praseodymium salt ()
or
() to 10 mL of the target solvent (Water, Ethanol, or Methanol) in a glass vial.
 - Expert Tip: Ensure visible solid remains at the bottom. If all solid dissolves, add more.
- Equilibration (The Critical Step):
 - Sonicate for 20 minutes to break up crystal aggregates.
 - Place in the temperature-controlled bath at 25°C for 24 hours with continuous agitation (magnetic stir bar).
 - Self-Validation: Measure the temperature of the liquid directly, not just the bath.
- Filtration & Sampling:
 - Stop stirring and let settle for 30 minutes.
 - Using a pre-warmed syringe (to prevent precipitation in the needle), withdraw 2 mL of supernatant.
 - Filter through a $0.22\ \mu\text{m}$ filter into a pre-weighed weighing dish (

).

- **Drying & Measurement:**

- Weigh the dish + liquid immediately (

).

- Evaporate solvent in a vacuum oven at 80°C (for water) or 50°C (for ethanol) until constant weight is achieved (

).

- Caution: Praseodymium salts are hygroscopic. Cool in a desiccator with _____ before final weighing.

- **Calculation:**

Experimental Workflow Diagram

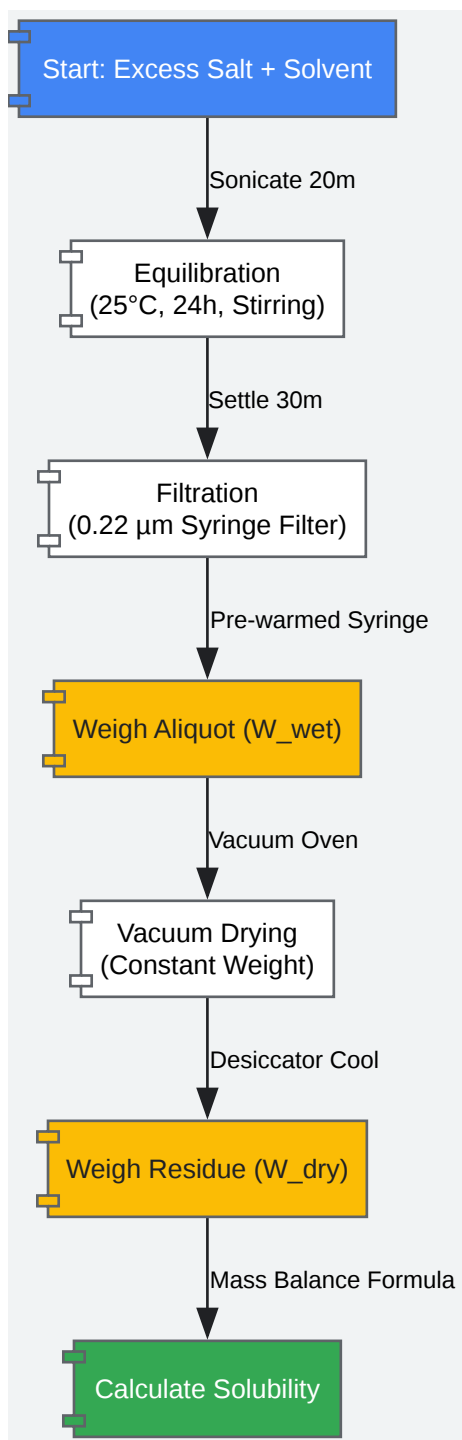

[Click to download full resolution via product page](#)

Figure 2: Step-by-step gravimetric workflow for determining solubility limits.

Application Implications

When to use Praseodymium Chloride ():

- Aqueous Synthesis: Ideal for coprecipitation reactions (e.g., forming or) due to its extremely high water solubility and stability.
- Cost-Sensitive Applications: Generally more available and cost-effective than the bromide.
- General Catalysis: Used as a Lewis acid where the counter-ion does not participate in the reaction.

When to use Praseodymium Bromide ():

- Organic Solvents: The "softer" bromide ion often confers better solubility in polar organic solvents (like alcohols or acetonitrile) compared to the harder chloride.
- Optical Materials: Used in specific crystal growth applications (e.g., scintillators) where chloride impurities might quench fluorescence.
- Specialized Catalysis: In reactions requiring a more labile ligand; the bromide ion is a better leaving group than chloride in certain substitution reactions.

References

- Wikipedia. Praseodymium(III) chloride.^{[1][2][3][4][5][6]} Retrieved from [\[Link\]\[1\]\[3\]\[4\]\[5\]](#)
- American Elements. Praseodymium Bromide.^{[1][2][7][8][9][10][11]} Retrieved from [\[Link\]](#)
- ChemEurope. Praseodymium(III) chloride Properties. Retrieved from [\[Link\]\[4\]](#)
- Royal Society of Chemistry. Solubility trends of metal halides. Retrieved from [\[Link\]](#)

Need Custom Synthesis?

BenchChem offers custom synthesis for rare earth carbides and specific isotopic labeling.

Email: info@benchchem.com or [Request Quote Online](#).

Sources

BenchChem

Our mission is to be the trusted global source of essential and advanced chemicals, empowering scientists and researchers to drive progress in science and industry.

Contact

Address: 3281 E Guasti Rd

Ontario, CA 91761, United States

Phone: (601) 213-4426

Email: info@benchchem.com

[Contact our Ph.D. Support Team for a compatibility check](#)