

Application Note: Synthesis and Evaluation of Piperazinone-Based HIV-1 Capsid Modulators

Author: BenchChem Technical Support Team. **Date:** May 2026

Compound of Interest

Compound Name: (R)-6-Benzylpiperazin-2-one

Cat. No.: B1508482

[Get Quote](#)

Introduction: Targeting the HIV-1 Capsid, A Fortress of Opportunity

The human immunodeficiency virus type 1 (HIV-1) remains a formidable global health challenge. While combination antiretroviral therapy (cART) has transformed HIV-1 into a manageable chronic condition, the continuous emergence of drug-resistant strains necessitates the development of novel therapeutics with unique mechanisms of action.^[1] The HIV-1 capsid protein (CA), a structural protein that forms a conical shell around the viral genome, has emerged as a critical and clinically validated therapeutic target.^{[1][2][3]}

The capsid is far more than a passive container; it is a dynamic participant in multiple, essential stages of the viral lifecycle. Following viral entry, the capsid core must undergo a precisely timed disassembly process, known as "uncoating," to release the viral genome for reverse transcription.^{[4][5]} The intact or partially uncoated capsid also interacts with host cell factors, such as cleavage and polyadenylation specificity factor 6 (CPSF6) and nucleoporin 153 (NUP153), to facilitate transport through the cytoplasm and import into the nucleus.^{[6][7]} In the late stages of replication, newly synthesized CA monomers assemble to form immature capsids, which mature into the infectious conical core.^{[7][8]}

This multifaceted functionality makes the CA protein an ideal target for disruption. Capsid modulators are a novel class of antiretrovirals that interfere with these processes. A promising strategy in this area involves the use of piperazinone scaffolds. The piperazine ring is considered a "privileged scaffold" in medicinal chemistry due to its synthetic tractability and its presence in numerous FDA-approved drugs.[9][10][11][12] Specifically, peptidomimetics bearing a 2-piperazinone core have been designed to mimic the phenylalanine-glycine (FG) motif found in host factors that bind to the capsid, such as PF74.[2][13] These compounds bind to a highly conserved pocket at the interface between the N-terminal domain (NTD) and C-terminal domain (CTD) of adjacent CA monomers within the assembled capsid hexamer.[1][8][14]

This application note provides a detailed guide for the rational design, chemical synthesis, and biological evaluation of HIV-1 capsid modulators built upon a piperazinone scaffold.

Mechanism of Action: Inducing Lethal Hyperstability

Piperazinone-based capsid modulators exert their antiviral effect through a multi-stage mechanism that disrupts the delicate equilibrium of capsid stability. By binding to the NTD-CTD interface, these molecules act as molecular "glue," leading to the following disruptive events:

- **Inhibition of Uncoating:** The primary mechanism is the hyper-stabilization of the capsid lattice.[5][7] This "lethal hyperstability" prevents the timely and coordinated disassembly of the core after cell entry, effectively trapping the viral genome and preventing the initiation of reverse transcription.[5][7]
- **Disruption of Nuclear Import:** The binding of the modulator to the CA hexamer physically blocks the interaction sites required for host factors like CPSF6 and NUP153, which are essential for trafficking the viral core to and through the nuclear pore complex.[2][7]
- **Aberrant Assembly and Maturation:** During the late phase of the viral lifecycle, the presence of these modulators interferes with the proper assembly of new CA proteins. This leads to the formation of malformed, non-infectious virions.[7][8]

This multi-pronged attack on the viral lifecycle is a key advantage of capsid-targeting antivirals, as exemplified by the first-in-class approved drug, Lenacapavir.[8][15]

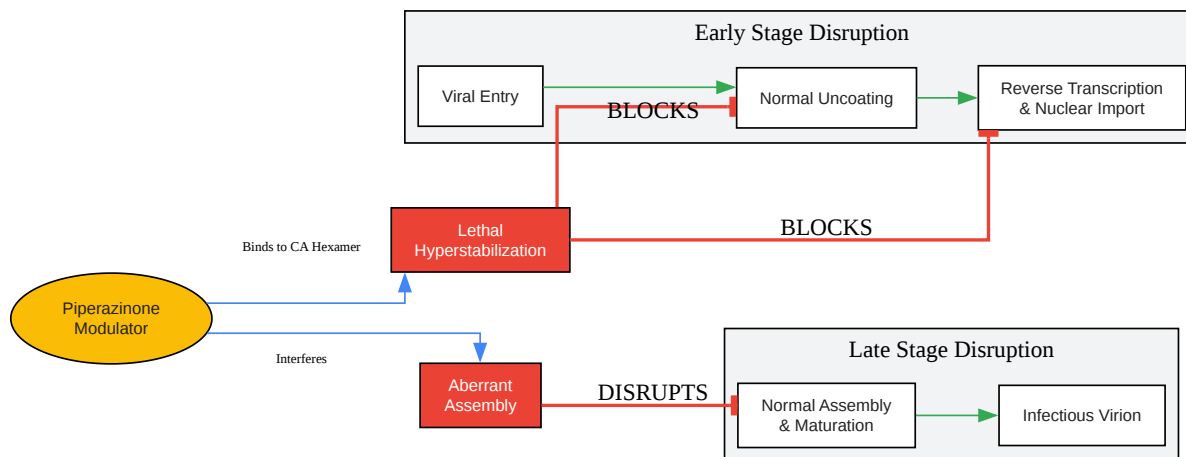

[Click to download full resolution via product page](#)

Caption: Mechanism of piperazinone capsid modulator action.

Synthetic Strategy and Protocols

The synthesis of piperazinone-based HIV-1 capsid modulators can be approached through a convergent strategy, focusing on the construction of a central piperazinone core followed by the coupling of key side chains that mimic the interactions of natural binding partners.

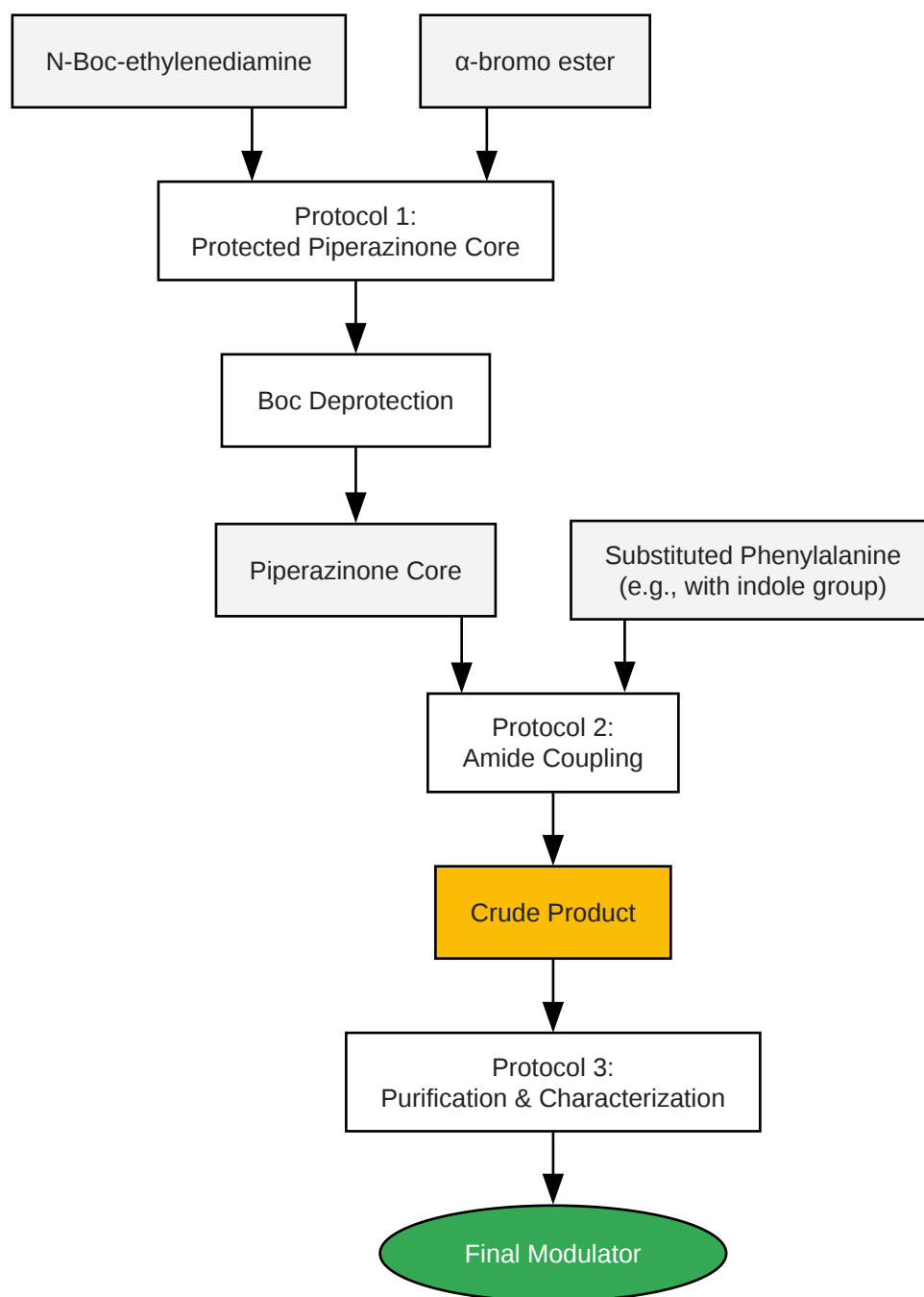

[Click to download full resolution via product page](#)

Caption: General synthetic workflow for piperazinone modulators.

Protocol 1: Synthesis of the Piperazinone Core (Example: tert-butyl 3-oxo-1-piperazinecarboxylate)

This protocol describes a common method for synthesizing the protected piperazinone ring, which serves as the central scaffold.

Rationale: This two-step process involves an initial nucleophilic substitution followed by an intramolecular cyclization. The Boc protecting group is used for its stability under the reaction conditions and its facile removal under acidic conditions.

Materials:

- N-Boc-ethylenediamine
- Ethyl bromoacetate
- Potassium carbonate (K_2CO_3)
- Acetonitrile (ACN)
- Sodium ethoxide (NaOEt)
- Ethanol (EtOH)
- Diethyl ether, Ethyl acetate (EtOAc), Hexanes, Saturated sodium bicarbonate ($NaHCO_3$), Brine, Anhydrous sodium sulfate (Na_2SO_4)
- TLC plates, Silica gel for column chromatography

Procedure:

- Alkylation:
 - To a solution of N-Boc-ethylenediamine (1.0 eq) in ACN, add K_2CO_3 (2.5 eq).
 - Add ethyl bromoacetate (1.1 eq) dropwise at room temperature.
 - Stir the reaction mixture at 60°C for 16 hours. Monitor reaction completion by TLC.
 - Filter the solid and concentrate the filtrate under reduced pressure.

- Purify the crude product by flash column chromatography to yield the alkylated intermediate.
- Cyclization:
 - Dissolve the intermediate from the previous step in EtOH.
 - Add a solution of NaOEt (1.5 eq) in EtOH dropwise at 0°C.
 - Allow the reaction to warm to room temperature and stir for 4 hours.
 - Quench the reaction by adding saturated aq. NaHCO₃.
 - Extract the product with EtOAc (3x).
 - Wash the combined organic layers with brine, dry over Na₂SO₄, and concentrate in vacuo.
 - The resulting solid is the Boc-protected piperazinone core.
- Deprotection:
 - Dissolve the protected core in a solution of 4M HCl in dioxane or trifluoroacetic acid (TFA) in dichloromethane (DCM).
 - Stir for 1-2 hours at room temperature.
 - Concentrate under reduced pressure and triturate with diethyl ether to obtain the piperazinone salt, which can be used directly or neutralized for the next step.

Protocol 2: Amide Coupling to the Piperazinone Core

This protocol details the coupling of the desired side chain (e.g., a modified phenylalanine) to the free secondary amine of the piperazinone core.

Rationale: HATU is a highly efficient peptide coupling reagent that minimizes side reactions and racemization, making it ideal for coupling carboxylic acids to the piperazinone nitrogen. DIPEA is a non-nucleophilic base used to scavenge the acid formed during the reaction.

Materials:

- Piperazinone core (from Protocol 1)
- Carboxylic acid side chain (e.g., N-protected-3-(1H-indol-3-yl)-L-alanine)
- HATU (1-[Bis(dimethylamino)methylene]-1H-1,2,3-triazolo[4,5-b]pyridinium 3-oxid hexafluorophosphate)
- N,N-Diisopropylethylamine (DIPEA)
- Dimethylformamide (DMF), anhydrous

Procedure:

- Dissolve the carboxylic acid side chain (1.0 eq) in anhydrous DMF.
- Add HATU (1.1 eq) and DIPEA (3.0 eq) to the solution and stir for 15 minutes at room temperature to pre-activate the acid.
- Add a solution of the piperazinone core (1.2 eq) in DMF to the activated acid mixture.
- Stir the reaction at room temperature for 12-18 hours. Monitor completion by LC-MS or TLC.
- Upon completion, dilute the reaction mixture with EtOAc and wash with 1N HCl, saturated aq. NaHCO₃, and brine.
- Dry the organic layer over Na₂SO₄, filter, and concentrate under reduced pressure.

Protocol 3: Purification and Characterization

Rationale: Proper purification is critical to remove unreacted starting materials and coupling reagents. Characterization confirms the identity and purity of the final compound before biological testing.

Procedure:

- Purification:
 - Purify the crude product from Protocol 2 using flash column chromatography on silica gel. A typical eluent system would be a gradient of methanol in dichloromethane or ethyl

acetate in hexanes.

- Characterization:
 - ^1H and ^{13}C NMR: Dissolve the purified compound in a suitable deuterated solvent (e.g., DMSO- d_6 , CDCl_3) to confirm the chemical structure.
 - High-Resolution Mass Spectrometry (HRMS): Determine the exact mass of the compound to confirm its elemental composition.
 - Purity Analysis (HPLC): Determine the purity of the final compound using reverse-phase HPLC, aiming for >95% purity for biological assays.

Biological Evaluation Protocols

Once synthesized and characterized, the compounds must be evaluated for their ability to bind the CA protein and inhibit viral replication in a cellular context.

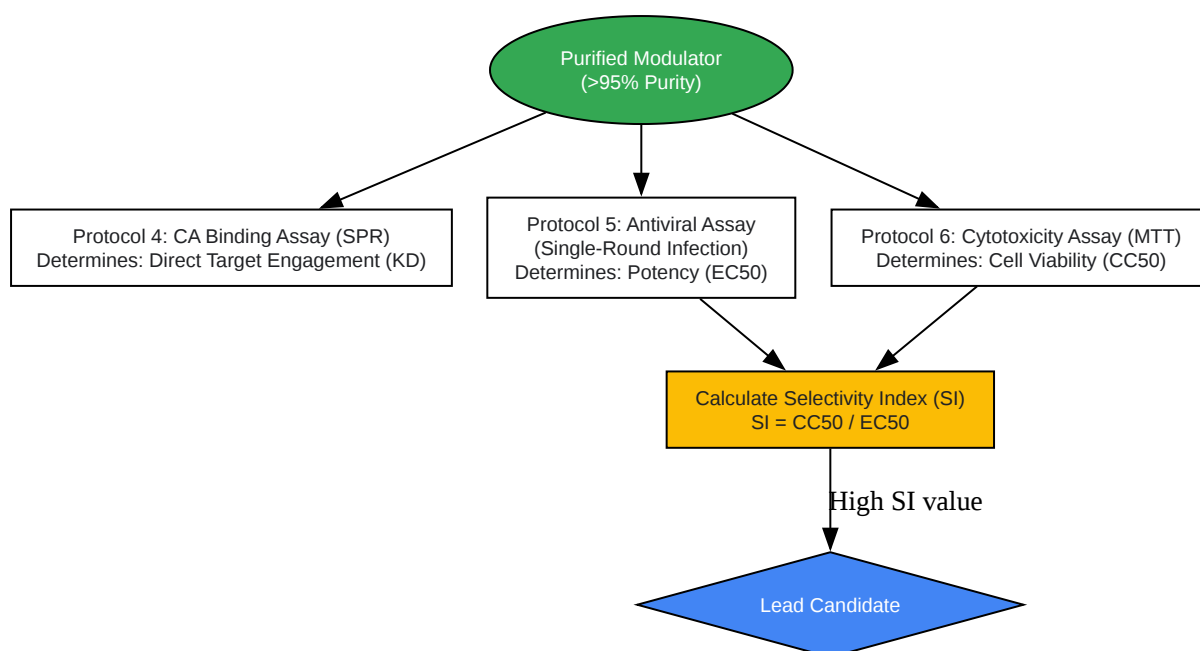

[Click to download full resolution via product page](#)

Caption: Workflow for the biological evaluation of modulators.

Protocol 4: Capsid Binding Assay (Surface Plasmon Resonance)

Objective: To quantify the direct binding affinity (K_D) of the synthesized modulator to both monomeric and hexameric forms of the HIV-1 CA protein. A preference for the hexamer is characteristic of this class of inhibitors.^{[1][16]}

Materials:

- SPR instrument (e.g., Biacore)
- CM5 sensor chip
- Amine coupling kit (EDC, NHS, ethanolamine)
- Recombinant HIV-1 CA protein (monomer and disulfide-stabilized hexamer)
- Synthesized compound library
- Running buffer (e.g., HBS-EP+)

Procedure:

- Immobilization: Immobilize the CA monomer and hexamer proteins onto separate flow cells of a CM5 sensor chip via standard amine coupling.
- Binding Analysis:
 - Prepare a serial dilution of the synthesized modulator in running buffer (e.g., 0.1 to 10 μM).
 - Inject the compound solutions over the flow cells at a constant flow rate.
 - Record the association and dissociation phases.
 - Regenerate the surface between injections using a mild acid or base pulse.

- Data Analysis: Fit the resulting sensorgrams to a suitable binding model (e.g., 1:1 Langmuir) to determine the association rate (k_a), dissociation rate (k_d), and the equilibrium dissociation constant ($K_D = k_d/k_a$).

Protocol 5: Antiviral Activity (Single-Round Infection Assay)

Objective: To determine the half-maximal effective concentration (EC_{50}) of the modulator required to inhibit HIV-1 infection in a cell-based model.[\[17\]](#)

Materials:

- Target cells (e.g., U87.CD4.CCR5 or TZM-bl cells)
- VSV-G pseudotyped HIV-1 reporter virus (expressing luciferase or GFP)
- 96-well cell culture plates
- Complete growth medium
- Luciferase substrate/reagent

Procedure:

- Seed target cells in a 96-well plate and incubate for 24 hours.
- Prepare serial dilutions of the test compound in growth medium.
- Add the compound dilutions to the cells, followed by a fixed amount of the reporter virus.
- Incubate for 48 hours at 37°C.
- Quantify the reporter signal (luciferase activity or GFP fluorescence).
- Plot the percentage of infection inhibition versus the log of the compound concentration and fit the data to a dose-response curve to calculate the EC_{50} value.

Protocol 6: Cytotoxicity Assay (MTT Assay)

Objective: To determine the half-maximal cytotoxic concentration (CC_{50}) and calculate the modulator's selectivity index (SI).

Materials:

- Target cells (same as in Protocol 5)
- 96-well cell culture plates
- MTT reagent (3-(4,5-dimethylthiazol-2-yl)-2,5-diphenyltetrazolium bromide)
- Solubilization buffer (e.g., DMSO or acidic isopropanol)

Procedure:

- Seed cells in a 96-well plate and incubate for 24 hours.
- Add serial dilutions of the test compound to the cells (in parallel with the antiviral assay).
- Incubate for 48 hours.
- Add MTT reagent to each well and incubate for 2-4 hours, allowing viable cells to convert MTT to formazan crystals.
- Add solubilization buffer to dissolve the crystals.
- Measure the absorbance at 570 nm.
- Plot cell viability versus log of the compound concentration to calculate the CC_{50} .
- Calculate the Selectivity Index (SI) as $SI = CC_{50} / EC_{50}$. A higher SI value indicates a more promising therapeutic window.

Data Presentation

Results from the biological evaluation should be summarized in a clear, tabular format to allow for easy comparison of structure-activity relationships (SAR).

Compound ID	Modification	CA Hexamer K _D (μM)	Antiviral EC ₅₀ (μM)	Cytotoxicity CC ₅₀ (μM)	Selectivity Index (SI)
PF74 (Ref)	Indole	0.159	0.75	>50	>66
PIP-001	4-fluoroindole	5.89	6.0	>100	>16
PIP-002	Benzene	12.3	21.8	>100	>4.5
PIP-003	N-methylindole	0.95	1.2	>100	>83

Note: Data are hypothetical and for illustrative purposes, inspired by published results.^{[1][2][18]}

Conclusion and Future Directions

The piperazinone scaffold represents a versatile and effective platform for the design and synthesis of novel HIV-1 capsid modulators. The protocols outlined in this application note provide a robust framework for creating these compounds and evaluating their potential as next-generation antiretrovirals. The key to success lies in the multi-parameter optimization of binding affinity, antiviral potency, and cellular toxicity. Future work should focus on exploring diverse substitutions on the core scaffold to improve pharmacokinetic properties and metabolic stability, ultimately leading to the development of candidates with potent, long-acting therapeutic profiles.

References

- Design, synthesis, and mechanistic study of 2-piperazineone-bearing peptidomimetics as novel HIV capsid modulators. RSC Medicinal Chemistry. Available at: [\[Link\]](#)
- Design, synthesis, and mechanistic study of 2-piperazineone-bearing peptidomimetics as novel HIV capsid modulators - PMC. National Center for Biotechnology Information. Available at: [\[Link\]](#)
- Lenacapavir Synthesis Highlights. Drug Hunter. Available at: [\[Link\]](#)

- Design, synthesis, and mechanistic study of 2-piperazineone-bearing peptidomimetics as novel HIV capsid modulators | Request PDF. ResearchGate. Available at: [\[Link\]](#)
- Discovery and Mechanistic Investigation of Piperazinone Phenylalanine Derivatives with Terminal Indole or Benzene Ring as Novel HIV-1 Capsid Modulators - PubMed. National Center for Biotechnology Information. Available at: [\[Link\]](#)
- Discovery and Mechanistic Investigation of Piperazinone Phenylalanine Derivatives with Terminal Indole or Benzene Ring as Novel HIV-1 Capsid Modulators. MDPI. Available at: [\[Link\]](#)
- Discovery of Lenacapavir: First-in-Class Twice-Yearly Capsid Inhibitor for HIV-1 Treatment and Pre-exposure Prophylaxis - PMC. National Center for Biotechnology Information. Available at: [\[Link\]](#)
- Recent advances in the piperazine based antiviral agents: A remarkable heterocycle for antiviral research. Arabian Journal of Chemistry. Available at: [\[Link\]](#)
- Discovery and Mechanistic Investigation of Piperazinone Phenylalanine Derivatives with Terminal Indole or Benzene Ring as Novel HIV-1 Capsid Modulators - PMC. National Center for Biotechnology Information. Available at: [\[Link\]](#)
- A Concise Route to Lenacapavir Sodium: First Demonstration of One-Pot Heck-Suzuki Coupling in Lenacapavir API Synthesis. ChemRxiv. Available at: [\[Link\]](#)
- Lenacapavir - Wikipedia. Wikipedia. Available at: [\[Link\]](#)
- Preparation of a Key Intermediate En Route to the Anti-HIV Drug Lenacapavir. ACS Publications. Available at: [\[Link\]](#)
- Discovery of Novel Piperazinone-Fused Hydroxypyridinones Inhibiting Herpes Simplex Virus Gene Transcription and Viral Replication - PubMed. National Center for Biotechnology Information. Available at: [\[Link\]](#)
- The primary mechanism for highly potent inhibition of HIV-1 maturation by lenacapavir. bioRxiv. Available at: [\[Link\]](#)

- Cell-free assays reveal that the HIV-1 capsid protects reverse transcripts from cGAS immune sensing. PLOS. Available at: [\[Link\]](#)
- Disassembling the Nature of Capsid: Biochemical, Genetic, and Imaging Approaches to Assess HIV-1 Capsid Functions - PMC. National Center for Biotechnology Information. Available at: [\[Link\]](#)
- The Fate of HIV-1 Capsid: A Biochemical Assay for HIV-1 Uncoating - PMC. National Center for Biotechnology Information. Available at: [\[Link\]](#)
- Mini-Lecture Series: HIV Capsid Inhibitors: Mechanism of Action. YouTube. Available at: [\[Link\]](#)
- What are HIV-1 capsid inhibitors and how do they work?. Patsnap. Available at: [\[Link\]](#)
- An Overview of Piperazine Scaffold as Promising Nucleus for Different Therapeutic Targets. Ingenta Connect. Available at: [\[Link\]](#)
- Piperazine Derivatives: A Privileged Scaffold in Modern Synthesis and Medicinal Chemistry. Chemistry Europe. Available at: [\[Link\]](#)
- Piperazine-based HIV-1 entry inhibitors: Massive in silico library design and screening for gp120 attachment inhibitors. bioRxiv. Available at: [\[Link\]](#)
- Pharmacologic hyperstabilisation of the HIV-1 capsid lattice induces capsid failure. eLife. Available at: [\[Link\]](#)
- Exploring Modifications of an HIV-1 Capsid Inhibitor: Design, Synthesis, and Mechanism of Action. Drexel University. Available at: [\[Link\]](#)
- Piperazine Derivatives: A Privileged Scaffold in Modern Synthesis and Medicinal Chemistry. Wiley Online Library. Available at: [\[Link\]](#)

Need Custom Synthesis?

BenchChem offers custom synthesis for rare earth carbides and specific isotopic labeling.

Email: info@benchchem.com or [Request Quote Online](#).

Sources

- [1. Discovery and Mechanistic Investigation of Piperazinone Phenylalanine Derivatives with Terminal Indole or Benzene Ring as Novel HIV-1 Capsid Modulators - PMC \[pmc.ncbi.nlm.nih.gov\]](#)
- [2. Design, synthesis, and mechanistic study of 2-piperazineone-bearing peptidomimetics as novel HIV capsid modulators - PMC \[pmc.ncbi.nlm.nih.gov\]](#)
- [3. What are HIV-1 capsid inhibitors and how do they work? \[synapse.patsnap.com\]](#)
- [4. The Fate of HIV-1 Capsid: A Biochemical Assay for HIV-1 Uncoating - PMC \[pmc.ncbi.nlm.nih.gov\]](#)
- [5. Pharmacologic hyperstabilisation of the HIV-1 capsid lattice induces capsid failure | eLife \[elifesciences.org\]](#)
- [6. Disassembling the Nature of Capsid: Biochemical, Genetic, and Imaging Approaches to Assess HIV-1 Capsid Functions - PMC \[pmc.ncbi.nlm.nih.gov\]](#)
- [7. m.youtube.com \[m.youtube.com\]](#)
- [8. The primary mechanism for highly potent inhibition of HIV-1 maturation by lenacapavir - PMC \[pmc.ncbi.nlm.nih.gov\]](#)
- [9. Recent advances in the piperazine based antiviral agents: A remarkable heterocycle for antiviral research - Arabian Journal of Chemistry \[arabjchem.org\]](#)
- [10. An Overview of Piperazine Scaffold as Promising Nucleus for Diffe...: Ingenta Connect \[ingentaconnect.com\]](#)
- [11. researchgate.net \[researchgate.net\]](#)
- [12. Piperazine Derivatives: A Privileged Scaffold in Modern Synthesis and Medicinal Chemistry - PMC \[pmc.ncbi.nlm.nih.gov\]](#)
- [13. Design, synthesis, and mechanistic study of 2-piperazineone-bearing peptidomimetics as novel HIV capsid modulators - RSC Medicinal Chemistry \(RSC Publishing\) \[pubs.rsc.org\]](#)
- [14. Discovery of Lenacapavir: First-in-Class Twice-Yearly Capsid Inhibitor for HIV-1 Treatment and Pre-exposure Prophylaxis - PMC \[pmc.ncbi.nlm.nih.gov\]](#)
- [15. Lenacapavir - Wikipedia \[en.wikipedia.org\]](#)
- [16. Discovery and Mechanistic Investigation of Piperazinone Phenylalanine Derivatives with Terminal Indole or Benzene Ring as Novel HIV-1 Capsid Modulators \[mdpi.com\]](#)
- [17. francis-lab.create.fsu.edu \[francis-lab.create.fsu.edu\]](#)

- [18. Discovery and Mechanistic Investigation of Piperazinone Phenylalanine Derivatives with Terminal Indole or Benzene Ring as Novel HIV-1 Capsid Modulators - PubMed](#) [pubmed.ncbi.nlm.nih.gov]
- To cite this document: BenchChem. [Application Note: Synthesis and Evaluation of Piperazinone-Based HIV-1 Capsid Modulators]. BenchChem, [2026]. [Online PDF]. Available at: [https://www.benchchem.com/product/b1508482/docs#application-note-synthesis-and-evaluation-of-piperazinone-based-hiv-1-capsid-modulators]

Disclaimer & Data Validity:

The information provided in this document is for Research Use Only (RUO) and is strictly not intended for diagnostic or therapeutic procedures. While BenchChem strives to provide accurate protocols, we make no warranties, express or implied, regarding the fitness of this product for every specific experimental setup.

Technical Support: The protocols provided are for reference purposes. Unsure if this reagent suits your experiment?

Need Industrial/Bulk Grade? [Request Custom Synthesis Quote](#)

BenchChem

Our mission is to be the trusted global source of essential and advanced chemicals, empowering scientists and researchers to drive progress in science and industry.

Contact

Address: 3281 E Guasti Rd
Ontario, CA 91761, United States
Phone: (601) 213-4426
Email: info@benchchem.com

[Contact our Ph.D. Support Team for a compatibility check](#)

