

Technical Guide: TLC Monitoring of N-[4-(Decyloxy)phenyl]acetamide Synthesis

Author: BenchChem Technical Support Team. **Date:** April 2026

Compound of Interest

Compound Name: *N*-[4-(Decyloxy)phenyl]acetamide

CAS No.: 55792-68-2

Cat. No.: B15076872

[Get Quote](#)

Executive Summary & Reaction Context

Product: **N-[4-(Decyloxy)phenyl]acetamide** (4-Decyloxyacetanilide) Reaction Type: Williamson Ether Synthesis (O-Alkylation) Significance: This transformation converts the polar phenolic hydroxyl group of paracetamol into a lipophilic decyl ether. This drastic change in polarity makes TLC an exceptionally robust method for monitoring reaction progress.

The Reaction Scheme

The synthesis involves the alkylation of 4-Acetamidophenol (Paracetamol) with 1-Bromodecane using a base (typically

) in a polar aprotic solvent (e.g., DMF or Acetone).

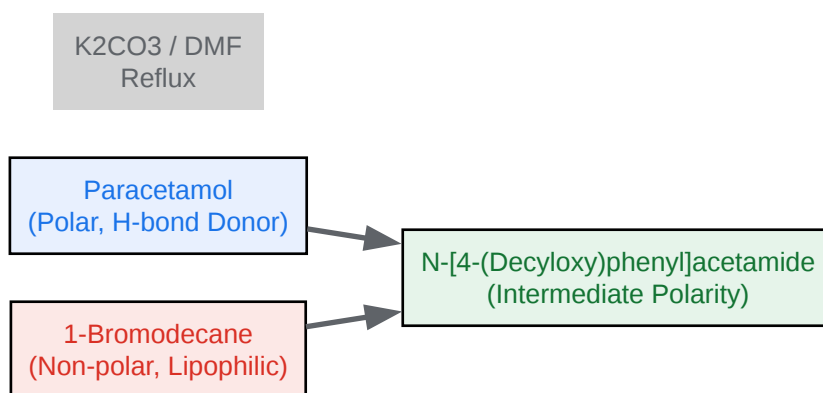

[Click to download full resolution via product page](#)

Figure 1: Reaction pathway showing the convergence of polar and non-polar starting materials into the product.

Critical Analysis of Components

Successful TLC monitoring requires understanding the physicochemical properties of each component. The polarity difference here is substantial, allowing for easy separation.

Component	Role	Polarity	Detection Method (Primary)	Detection Method (Secondary)
Paracetamol	Starting Material (Limiting)	High (Phenol + Amide)	UV (254 nm) - Strong	(Phenolic purple)
1-Bromodecane	Alkylating Agent (Excess)	Very Low (Alkyl chain)	Iodine Chamber (Brown)	(Weak/None*)
Product	Target Compound	Medium (Ether + Amide)	UV (254 nm) - Strong	Iodine (Lipophilic tail)

*Note: Pure alkyl halides are resistant to oxidation stains like

. Iodine adsorption is the most reliable visualization for 1-Bromodecane.

Experimental Protocol: Self-Validating TLC System

To ensure scientific integrity, this protocol uses a Dual-Visualization Strategy to account for the UV-inactive alkyl halide.

Step 1: Mobile Phase Optimization

A standard "drug discovery" solvent system of pure Ethyl Acetate or Methanol is too polar for the lipophilic product and starting bromide. A non-polar co-solvent is required.

- Recommended System: Hexane : Ethyl Acetate (60:40 v/v).
- Alternative: Toluene : Acetone (80:20 v/v) for higher resolution of aromatic impurities.

Step 2: Plate Preparation & Elution

- Stationary Phase: Silica Gel 60
(Aluminum or Glass backed).
- Spotting: Apply 3 spots:
 - Lane 1: Paracetamol (dissolved in MeOH).
 - Lane 2: Co-spot (Reaction Mixture).
 - Lane 3: 1-Bromodecane (dissolved in Hexane).
- Elution: Run until the solvent front reaches 80% of the plate height.

Step 3: Visualization Workflow

Because 1-Bromodecane is invisible under UV, you must perform sequential visualization.

- UV Check (254 nm): Circle the dark spots.^[1] (Visible: Paracetamol, Product).^{[2][3][4][5]}
- Iodine Stain: Place plate in an iodine vapor chamber for 2-3 minutes. (Visible: 1-Bromodecane, Product).

Data Interpretation: Value Comparison

The following values are representative for a Hexane : Ethyl Acetate (1:1) system.

Compound	Value (Approx)	Appearance (UV)	Appearance (Iodine)	Mechanistic Explanation
1-Bromodecane	0.85 - 0.95	Invisible	Brown Spot	Lacks polar functional groups; interacts minimally with silica. Travels with solvent front.[1]
Product	0.50 - 0.60	Dark Spot	Light Brown	Phenolic -OH (strong H-bond donor) is capped. The amide group still interacts with silica, preventing it from running as high as the bromide.
Paracetamol	0.15 - 0.25	Dark Spot	Faint/Yellow	Contains free Phenol and Amide. Strong Hydrogen bonding with silica silanols () retards migration.

Visualizing the Separation

The diagram below illustrates the expected plate appearance using the Dual-Visualization strategy.

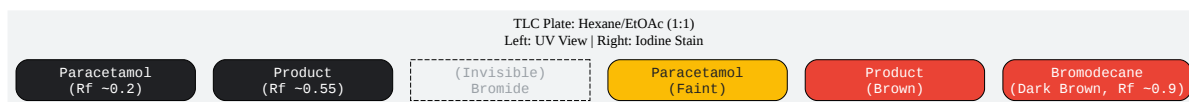

[Click to download full resolution via product page](#)

Figure 2: Simulated TLC plate showing the necessity of Iodine staining to detect the excess alkylating agent.

Troubleshooting & Expert Tips

- The "Ghost" Spot: If you see a spot at the very baseline ($R_f = 0$), it is likely the salt byproduct () or unreacted phenolate anion if the mixture was not acidified during workup.
- O-Alkylation vs N-Alkylation: Paracetamol has two nucleophilic sites (Phenolic O and Amide N).
 - O-Alkylated (Desired):
 $R_f \sim 0.55$.^[6]
 - N-Alkylated (Byproduct): Usually lower R_f than the O-product due to the retention of the free phenol (if N-alkylated only) or slightly higher if bis-alkylated. However, under standard basic conditions (), O-alkylation is highly favored.
- Monitoring Completion: The reaction is complete when the Paracetamol spot ($R_f = 0.2$) disappears. Do not rely on the disappearance of Bromodecane, as it is usually added in excess.

References

- Paracetamol Impurity Profiling
 - Source: Tusiimire, J. "Chromatographic purity profiling of a sample of paracetamol pure substance." [7] University of Strathclyde. [7]
 - Relevance: Establishes baseline and UV characteristics of paracetamol.
- TLC Visualization of Alkyl Halides
 - Source: "Visualizing a TLC plate." YouTube / Organic Lab Techniques. [8]
 - Relevance: Confirms Iodine vapor as the primary detection method for UV-inactive alkyl chains.
- General TLC of Analgesics
 - Source: "Chromatography of painkiller drugs." [9] ChemBAM.
 - Relevance: Provides comparative data for paracetamol in ethyl acetate.
- Properties of 1-Bromodecane
 - Source: Sigma-Aldrich Product Sheet (1-Bromodecane).
 - Relevance: Confirms lack of chromophores (UV inactivity)

Need Custom Synthesis?

BenchChem offers custom synthesis for rare earth carbides and specific isotopic labeling.

Email: info@benchchem.com or [Request Quote Online](#).

Sources

- [1. chembam.com](http://chembam.com) [chembam.com]
- [2. Acetaminophen | C8H9NO2 | CID 1983 - PubChem](https://pubchem.ncbi.nlm.nih.gov) [pubchem.ncbi.nlm.nih.gov]

- [3. A novel pipeline of 2-\(benzenesulfonamide\)-N-\(4-hydroxyphenyl\) acetamide analgesics that lack hepatotoxicity and retain antipyresis - PMC \[pmc.ncbi.nlm.nih.gov\]](#)
- [4. mdpi.com \[mdpi.com\]](#)
- [5. preprints.org \[preprints.org\]](#)
- [6. chembam.com \[chembam.com\]](#)
- [7. scribd.com \[scribd.com\]](#)
- [8. m.youtube.com \[m.youtube.com\]](#)
- [9. edu.rsc.org \[edu.rsc.org\]](#)
- To cite this document: BenchChem. [Technical Guide: TLC Monitoring of N-[4-(Decyloxy)phenyl]acetamide Synthesis]. BenchChem, [2026]. [Online PDF]. Available at: [<https://www.benchchem.com/product/b15076872/docs#technical-guide-tlc-monitoring-of-n-4-decyloxy-phenyl-acetamide-synthesis>]

Disclaimer & Data Validity:

The information provided in this document is for Research Use Only (RUO) and is strictly not intended for diagnostic or therapeutic procedures. While BenchChem strives to provide accurate protocols, we make no warranties, express or implied, regarding the fitness of this product for every specific experimental setup.

Technical Support: The protocols provided are for reference purposes. Unsure if this reagent suits your experiment?

Need Industrial/Bulk Grade? [Request Custom Synthesis Quote](#)

BenchChem

Our mission is to be the trusted global source of essential and advanced chemicals, empowering scientists and researchers to drive progress in science and industry.

Contact

Address: 3281 E Guasti Rd

Ontario, CA 91761, United States

Phone: (601) 213-4426

Email: info@benchchem.com

Contact our Ph.D. Support Team for a compatibility check