

Preventing degradation of MN-25 during experiments

Author: BenchChem Technical Support Team. **Date:** April 2026

Compound of Interest

Compound Name: MN-25
Cat. No.: B15073441

[Get Quote](#)

Technical Support Center: MN-25

Welcome to the technical support center for **MN-25**. This resource is designed to assist researchers, scientists, and drug development professionals in preventing the degradation of **MN-25** during experiments. Here you will find troubleshooting guides, frequently asked questions (FAQs), and detailed protocols to ensure the stability and integrity of your compound.

Frequently Asked Questions (FAQs)

Q1: What is **MN-25** and why is its stability a concern?

A1: **MN-25** is a novel small molecule inhibitor under investigation for its therapeutic potential. Due to its chemical structure, **MN-25** is susceptible to degradation under common experimental conditions, including exposure to light, fluctuations in pH, and elevated temperatures. Degradation can lead to a loss of biological activity and the formation of artifacts, resulting in unreliable and irreproducible experimental outcomes.

Q2: What are the primary factors that cause **MN-25** degradation?

A2: The main factors contributing to the degradation of **MN-25** are:

- **Light Exposure:** **MN-25** is photosensitive and can undergo photodegradation upon exposure to ambient light.
- **pH:** The compound is most stable within a narrow pH range. Deviations to more acidic or alkaline conditions can catalyze its breakdown.
- **Temperature:** Elevated temperatures accelerate the rate of degradation. Long-term storage at inappropriate temperatures can significantly reduce the purity and activity of the compound.
- **Oxidizing Agents:** The presence of oxidizing agents in solutions can lead to the oxidative degradation of **MN-25**.

Q3: How should I properly store **MN-25**?

A3: For optimal stability, **MN-25** should be stored as a dry powder at -20°C in a light-protected container. When in solution, it should be aliquoted into single-use volumes and stored at -80°C. Avoid repeated freeze-thaw cycles.

Troubleshooting Guides

This section addresses specific issues that may arise during your experiments with **MN-25**.

Issue 1: Loss of **MN-25** Activity in a Cell-Based Assay

Q: I am observing a significant decrease in the expected biological activity of **MN-25** in my cell-based assay. What could be the cause?

A: A loss of activity is often linked to the degradation of the compound. Consider the following potential causes and solutions:

- **Improper Solution Preparation:** Was the **MN-25** stock solution prepared and stored correctly? Refer to the Protocol for Preparation of **MN-25** Stock Solution.
- **Light Exposure During Experiment:** Were the experimental steps, including incubation, performed under light-protected conditions? Use amber-colored plates or cover standard plates with aluminum foil.

- pH of the Culture Medium: Is the pH of your cell culture medium within the optimal range for **MN-25** stability (pH 6.8-7.4)? Verify the pH of your medium before and after the addition of **MN-25**.
- Extended Incubation Time: Long incubation periods, especially at 37°C, can lead to thermal degradation. Consider reducing the incubation time if your experimental design allows.

Issue 2: Inconsistent Results Between Experiments

Q: My results with **MN-25** are highly variable from one experiment to the next. How can I improve reproducibility?

A: Inconsistent results are often a sign of variable **MN-25** integrity. To improve reproducibility, strictly adhere to the following:

- Standardized Solution Preparation: Always prepare fresh dilutions of **MN-25** from a properly stored, single-use aliquot of the stock solution for each experiment.
- Control for Environmental Factors: Consistently use light-protected containers and ensure the temperature and pH of your experimental system are maintained within the recommended ranges.
- Use of a Positive Control: Include a stable, known inhibitor in your experiments to confirm that the assay itself is performing consistently.

Quantitative Data on MN-25 Stability

The following tables summarize the impact of different experimental conditions on the stability of **MN-25**.

Table 1: Effect of pH on **MN-25** Stability

pH	Percent Degradation (after 24h at 25°C)
5.0	45%
6.0	15%
7.0	< 5%
8.0	25%
9.0	60%

Table 2: Effect of Light Exposure on **MN-25** Stability

Light Condition	Percent Degradation (after 8h at 25°C, pH 7.0)
Ambient Light	35%
Dark (Light-Protected)	< 2%

Table 3: Effect of Temperature on **MN-25** Stability

Temperature	Percent Degradation (after 24h, pH 7.0, Dark)
4°C	< 2%
25°C (Room Temp)	10%
37°C	20%

Experimental Protocols

Protocol for Preparation of **MN-25** Stock Solution

- Allow the vial of **MN-25** powder to equilibrate to room temperature before opening to prevent condensation.

- Under sterile conditions and in a dimly lit environment, dissolve the **MN-25** powder in anhydrous DMSO to a final concentration of 10 mM.
- Vortex briefly to ensure complete dissolution.
- Aliquot the stock solution into single-use, light-protected microcentrifuge tubes.
- Store the aliquots at -80°C.

Protocol for a Typical Cell-Based Assay with MN-25

- Culture cells to the desired density in a multi-well plate.
- Prepare fresh serial dilutions of **MN-25** from a thawed stock aliquot using pre-warmed (37°C), pH-stable (pH 7.2-7.4) cell culture medium. Perform this step in a dark or dimly lit environment.
- Add the **MN-25** dilutions to the appropriate wells. Include vehicle control (DMSO) wells.
- Immediately place the plate in a 37°C incubator. If the plate is not amber-colored, wrap it in aluminum foil to protect it from light.
- Incubate for the desired period.
- Proceed with the assay readout (e.g., viability, proliferation, or target-specific endpoint).

Visual Guides

The following diagrams illustrate key concepts related to **MN-25** degradation and its prevention.

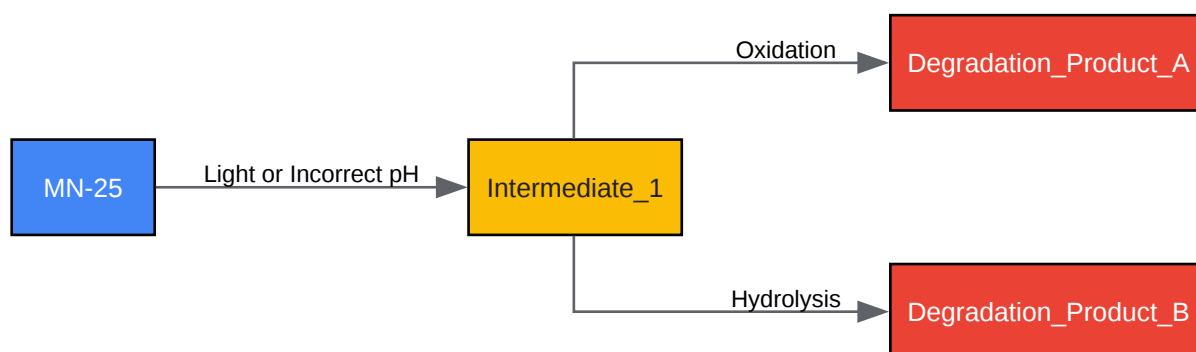

[Click to download full resolution via product page](#)

Caption: Hypothetical degradation pathway of **MN-25**.

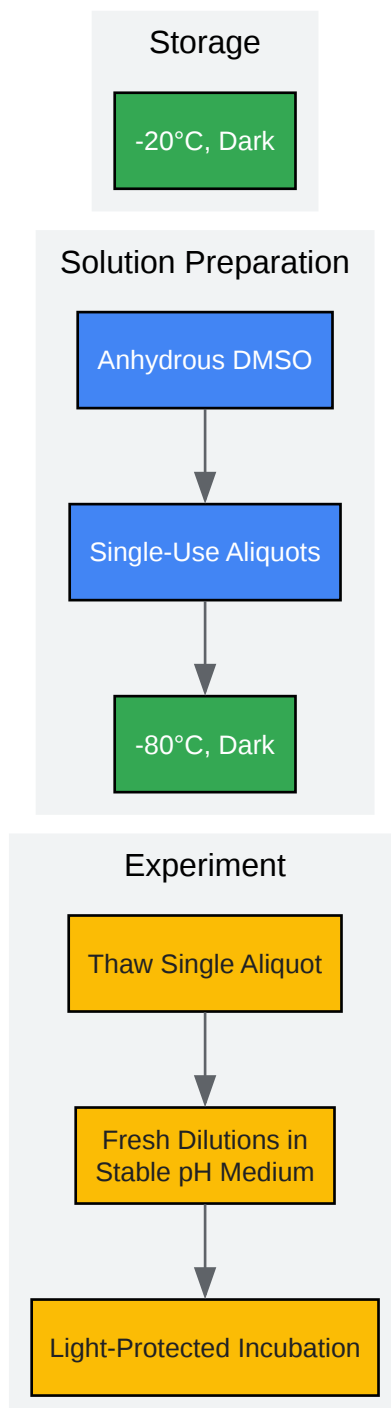

[Click to download full resolution via product page](#)

Caption: Recommended workflow for handling MN-25.

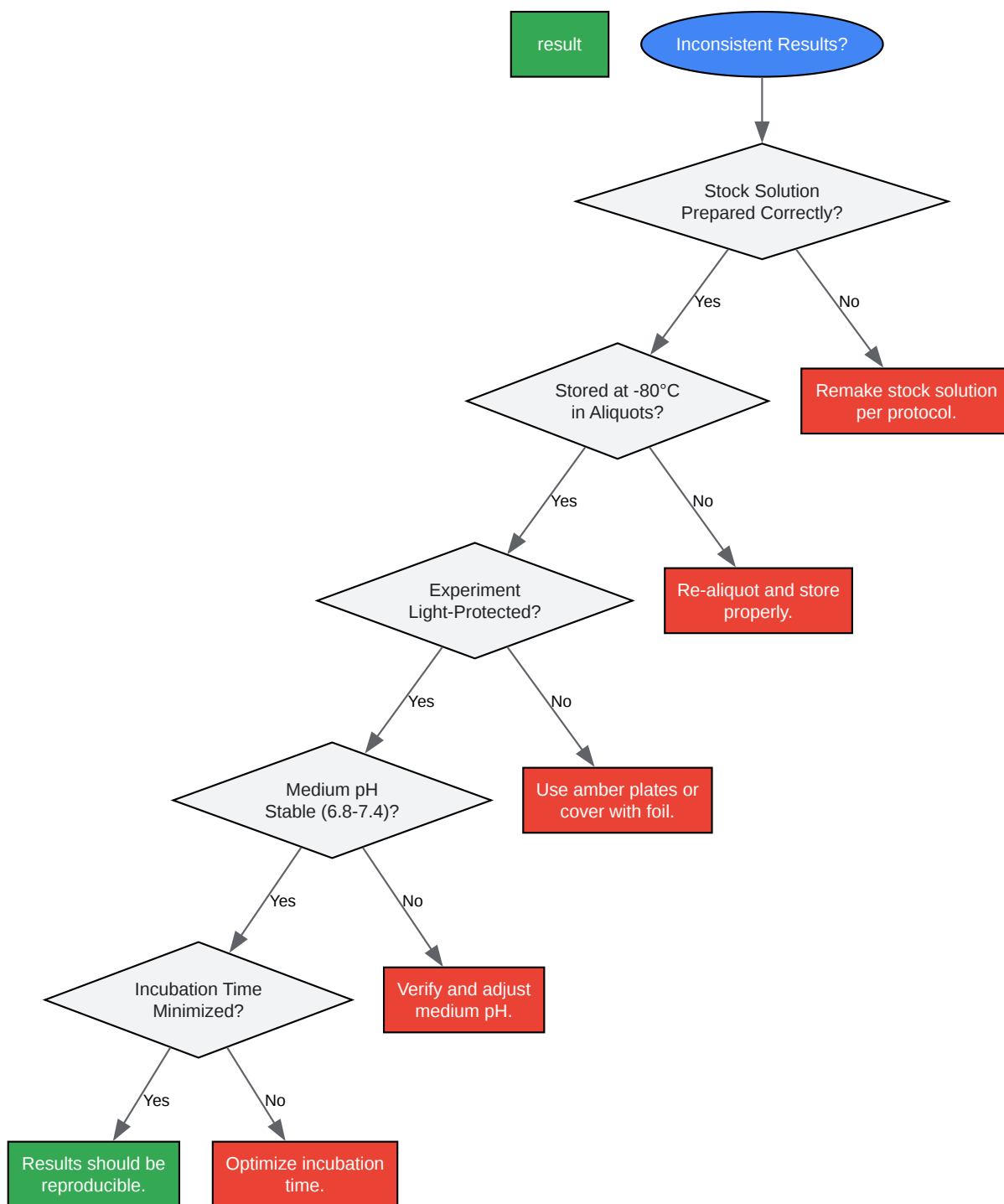

[Click to download full resolution via product page](#)

Caption: Troubleshooting decision tree for **MN-25**.

- To cite this document: BenchChem. [Preventing degradation of MN-25 during experiments]. BenchChem, [2026]. [Online PDF]. Available at: [<https://www.benchchem.com/product/b15073441/docs#preventing-degradation-of-mn-25-during-experiments>]

Disclaimer & Data Validity:

The information provided in this document is for Research Use Only (RUO) and is strictly not intended for diagnostic or therapeutic procedures. While BenchChem strives to provide accurate protocols, we make no warranties, express or implied, regarding the fitness of this product for every specific experimental setup.

Technical Support: The protocols provided are for reference purposes. Unsure if this reagent suits your experiment?

Need Industrial/Bulk Grade? [Request Custom Synthesis Quote](#)

BenchChem

Our mission is to be the trusted global source of essential and advanced chemicals, empowering scientists and researchers to drive progress in science and industry.

Contact

Address: 3281 E Guasti Rd
Ontario, CA 91761, United States
Phone: (601) 213-4426
Email: info@benchchem.com

[Contact our Ph.D. Support Team for a compatibility check](#)