

# Application Notes and Protocols for Testing Arzanol's Anti-inflammatory Activity

**Author:** BenchChem Technical Support Team. **Date:** April 2026

## Compound of Interest

Compound Name: Cararosinol A

Cat. No.: B15073832

[Get Quote](#)

Audience: Researchers, scientists, and drug development professionals.

## Introduction

Arzanol, a natural phloroglucinol  $\alpha$ -pyrone derived from *Helichrysum italicum*, has demonstrated significant anti-inflammatory properties.[1] Its mechanism of action involves the modulation of key inflammatory pathways, making it a compound of interest for therapeutic development. These application notes provide detailed protocols for in vitro and in vivo assays to characterize the anti-inflammatory activity of Arzanol, focusing on its effects on eicosanoid biosynthesis and major inflammatory signaling pathways.

## Data Presentation: Quantitative Inhibitory and Efficacy Data

The following tables summarize the reported quantitative data on Arzanol's inhibitory activity against key inflammatory enzymes and its in vivo efficacy.

Table 1: In Vitro Inhibitory Activity of Arzanol

Target Enzyme	Assay Type	IC50 Value	Reference
Cyclooxygenase-1 (COX-1)	Cell-free	2.3 - 9 $\mu$ M	[2]
Cyclooxygenase-2 (COX-2)	Cell-based (PGE <sub>2</sub> formation)	Not directly inhibitory on protein	[2]
5-Lipoxygenase (5-LOX)	Neutrophil-based	2.3 - 9 $\mu$ M	[2]
Microsomal Prostaglandin E <sub>2</sub> Synthase-1 (mPGES-1)	Cell-free	0.4 $\mu$ M	[2][3]
Nuclear Factor- $\kappa$ B (NF- $\kappa$ B)	Luciferase Reporter Assay	~12 $\mu$ M	[4]

Table 2: In Vivo Anti-inflammatory Efficacy of Arzanol

Animal Model	Treatment	Key Findings	Reference
Carrageenan-induced pleurisy in rats	3.6 mg/kg, i.p.	- 59% reduction in exudate formation- 48% reduction in cell infiltration- 47% inhibition of PGE <sub>2</sub> levels in exudate	[1][2]

## Experimental Protocols

This section provides detailed methodologies for key experiments to evaluate the anti-inflammatory properties of Arzanol.

### In Vitro Assays

#### 1. Cyclooxygenase (COX-1 and COX-2) Inhibition Assay (Cell-free Fluorometric Method)

This protocol is adapted from commercially available COX inhibitor screening kits and provides a method to assess the direct inhibitory effect of Arzanol on COX-1 and COX-2 enzymes.

- Materials:
  - Ovine COX-1 and human recombinant COX-2 enzymes
  - COX Assay Buffer (e.g., 100 mM Tris-HCl, pH 8.0)
  - Heme cofactor
  - Fluorometric probe (e.g., ADHP)
  - Arachidonic acid (substrate)
  - Arzanol
  - Selective COX-1 and COX-2 inhibitors (for controls, e.g., SC-560 and Celecoxib)
  - 96-well white opaque microplate
  - Fluorescence plate reader (Ex/Em = 535/587 nm)
- Procedure:
  - Prepare a reaction mixture containing COX Assay Buffer, COX Probe, and COX Cofactor.
  - In the wells of the 96-well plate, add the reaction mixture.
  - Add the test compound (Arzanol at various concentrations) or a vehicle control (e.g., DMSO).
  - Add the COX-1 or COX-2 enzyme to the respective wells.
  - Incubate the plate for 10-15 minutes at 37°C.
  - Initiate the reaction by adding arachidonic acid to all wells.
  - Immediately begin kinetic measurement of fluorescence intensity for 5-10 minutes at 25°C.

- Calculate the rate of reaction (slope of the linear portion of the kinetic curve).
- Determine the percent inhibition for each concentration of Arzanol relative to the vehicle control.
- Calculate the IC50 value by plotting percent inhibition versus Arzanol concentration.

## 2. 5-Lipoxygenase (5-LOX) Inhibition Assay (Human Neutrophil-based)

This protocol assesses the ability of Arzanol to inhibit 5-LOX activity in a cellular context, which is physiologically relevant.

- Materials:
  - Freshly isolated human neutrophils
  - Hanks' Balanced Salt Solution (HBSS) with calcium and magnesium
  - Arzanol
  - Calcium ionophore A23187
  - Methanol
  - Solid-phase extraction (SPE) columns
  - HPLC or UPLC-MS/MS system for leukotriene B<sub>4</sub> (LTB<sub>4</sub>) analysis
- Procedure:
  - Isolate human neutrophils from the peripheral blood of healthy donors using density gradient centrifugation.
  - Resuspend the neutrophils in HBSS.
  - Pre-incubate the neutrophil suspension with various concentrations of Arzanol or vehicle control for 15 minutes at 37°C.
  - Stimulate the cells with calcium ionophore A23187 to activate 5-LOX.

- Incubate for 10 minutes at 37°C.
- Terminate the reaction by adding cold methanol.
- Isolate the 5-LOX products (e.g., LTB<sub>4</sub>) from the supernatant using SPE.
- Quantify the amount of LTB<sub>4</sub> using a validated HPLC or UPLC-MS/MS method.
- Calculate the percent inhibition of LTB<sub>4</sub> formation by Arzanol and determine the IC<sub>50</sub> value.

### 3. Microsomal Prostaglandin E<sub>2</sub> Synthase-1 (mPGES-1) Inhibition Assay (Cell-free)

This assay directly measures the inhibitory effect of Arzanol on the enzymatic activity of mPGES-1.

- Materials:
  - Microsomal fraction containing recombinant human mPGES-1
  - Phosphate buffer (0.1 M, pH 7.4)
  - Glutathione (GSH)
  - Prostaglandin H<sub>2</sub> (PGH<sub>2</sub>) (substrate)
  - Arzanol
  - Stannous chloride (SnCl<sub>2</sub>) to terminate the reaction
  - ELISA kit for PGE<sub>2</sub> quantification or LC-MS/MS system
- Procedure:
  - Pre-incubate the microsomal preparation containing mPGES-1 with various concentrations of Arzanol or vehicle in phosphate buffer containing GSH for 15 minutes at 4°C.
  - Initiate the enzymatic reaction by adding PGH<sub>2</sub>.

- Incubate for 60-90 seconds at room temperature.
- Stop the reaction by adding SnCl<sub>2</sub>.
- Measure the amount of PGE<sub>2</sub> produced using a competitive ELISA or by LC-MS/MS.
- Calculate the percent inhibition of PGE<sub>2</sub> synthesis and determine the IC<sub>50</sub> value for Arzanol.

#### 4. NF-κB Activation Assay (Luciferase Reporter Gene Assay)

This assay quantifies the ability of Arzanol to inhibit the activation of the NF-κB signaling pathway.

- Materials:
  - HEK293 or similar cells
  - NF-κB luciferase reporter plasmid and a control plasmid (e.g., Renilla luciferase)
  - Transfection reagent
  - Cell culture medium and supplements
  - TNF-α or other NF-κB activator
  - Arzanol
  - Passive Lysis Buffer
  - Luciferase Assay System
  - Luminometer
- Procedure:
  - Co-transfect the cells with the NF-κB luciferase reporter plasmid and the control plasmid.
  - Seed the transfected cells into a 96-well plate and allow them to adhere overnight.

- Pre-treat the cells with various concentrations of Arzanol or vehicle for 1-2 hours.
- Stimulate the cells with TNF- $\alpha$  (e.g., 10 ng/mL) for 6-8 hours to activate the NF- $\kappa$ B pathway.
- Lyse the cells using Passive Lysis Buffer.
- Measure the firefly and Renilla luciferase activities using a luminometer.
- Normalize the firefly luciferase activity to the Renilla luciferase activity for each well.
- Calculate the percent inhibition of NF- $\kappa$ B activation by Arzanol and determine the IC50 value.

#### 5. Nrf2 Activation Assay (ARE-Luciferase Reporter Assay)

This protocol is designed to assess whether Arzanol can activate the Nrf2 antioxidant response pathway.

- Materials:
  - HepG2 or other suitable cells
  - Antioxidant Response Element (ARE) luciferase reporter vector and a control plasmid
  - Transfection reagent
  - Cell culture medium
  - Arzanol
  - Known Nrf2 activator (e.g., sulforaphane) as a positive control
  - Luciferase Assay System
  - Luminometer
- Procedure:

- Co-transfect cells with the ARE-luciferase reporter vector and a control vector.
- Plate the transfected cells in a 96-well plate and allow them to attach.
- Treat the cells with various concentrations of Arzanol, vehicle control, or a positive control for 16-24 hours.
- Lyse the cells and measure firefly and Renilla luciferase activities.
- Normalize the firefly luciferase signal to the Renilla luciferase signal.
- Determine the fold induction of ARE-luciferase activity by Arzanol compared to the vehicle control.

## In Vivo Assay

### 6. Carrageenan-Induced Pleurisy in Rats

This is an acute model of localized inflammation used to evaluate the in vivo anti-inflammatory efficacy of Arzanol.<sup>[5][6]</sup>

- Materials:
  - Male Wistar rats (180-220 g)
  - Carrageenan (1% w/v in sterile saline)
  - Arzanol
  - Vehicle (e.g., saline with 0.5% Tween 80)
  - Anesthetic (e.g., isoflurane)
  - Heparinized saline
  - Cell counting chamber (hemocytometer)
  - ELISA kit for PGE<sub>2</sub>

- Procedure:
  - Acclimatize the rats for at least one week.
  - Divide the animals into groups: vehicle control, Arzanol-treated (e.g., 3.6 mg/kg, i.p.), and a positive control (e.g., indomethacin).
  - Administer Arzanol or vehicle intraperitoneally 30-60 minutes before the inflammatory challenge.
  - Anesthetize the rats and inject 0.1-0.2 mL of 1% carrageenan solution into the pleural cavity.
  - At a predetermined time point (e.g., 4 hours) after carrageenan injection, euthanize the animals.
  - Carefully open the thoracic cavity and collect the pleural exudate by washing the cavity with a known volume of heparinized saline.
  - Measure the total volume of the collected exudate.
  - Determine the total leukocyte count in the exudate using a hemocytometer.
  - Centrifuge the exudate and store the supernatant at -80°C for subsequent analysis of inflammatory mediators like PGE<sub>2</sub> by ELISA.
  - Compare the exudate volume, leukocyte count, and PGE<sub>2</sub> levels between the Arzanol-treated group and the vehicle control group to determine the anti-inflammatory effect.

## Mandatory Visualizations

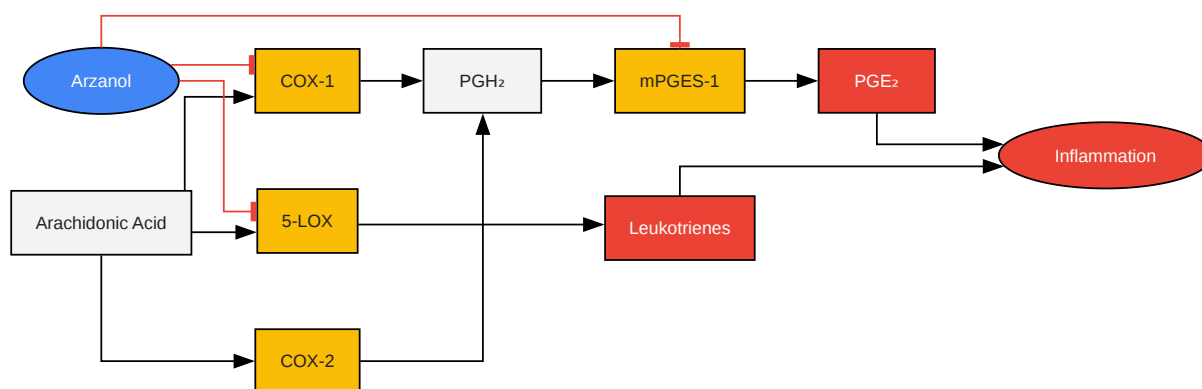

[Click to download full resolution via product page](#)

Caption: Arzanol's inhibition of the eicosanoid biosynthesis pathway.

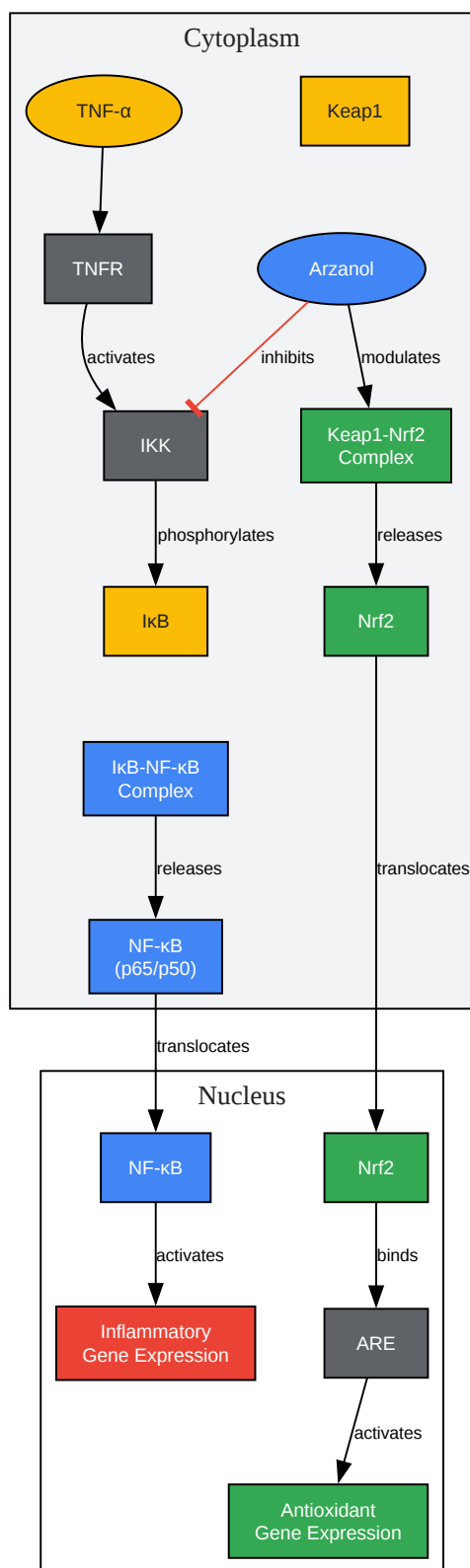

[Click to download full resolution via product page](#)

Caption: Arzanol's modulation of NF-κB and Nrf2 signaling pathways.

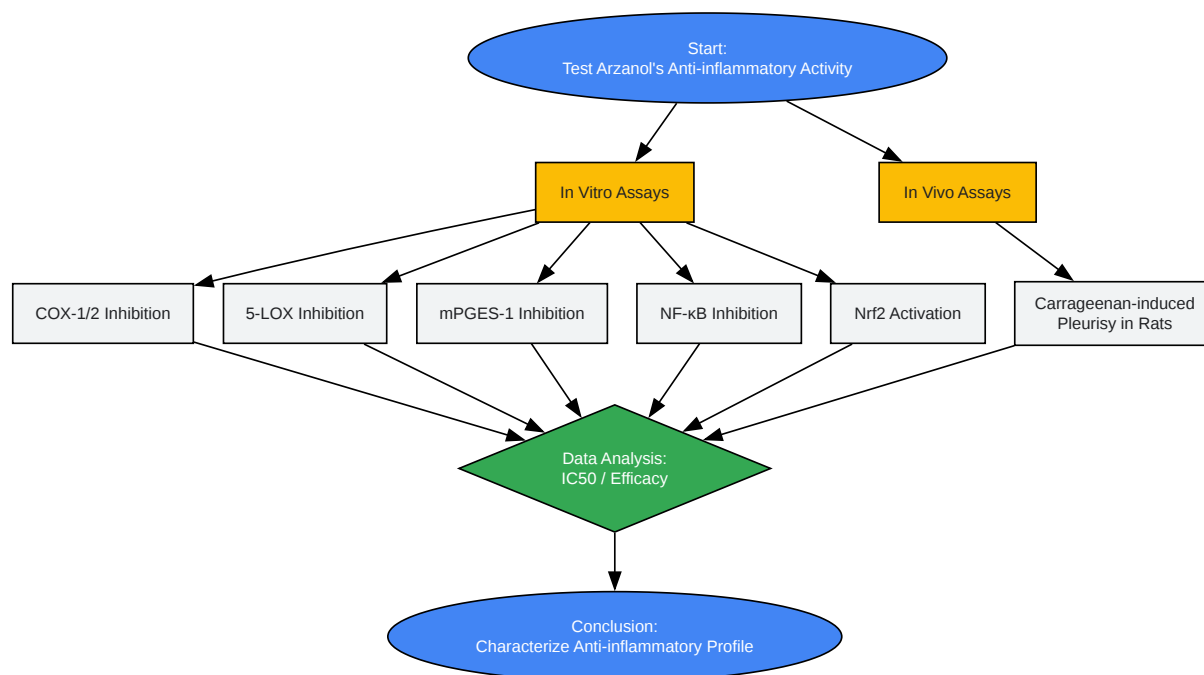

[Click to download full resolution via product page](#)

Caption: Experimental workflow for assessing Arzanol's anti-inflammatory activity.

### Need Custom Synthesis?

BenchChem offers custom synthesis for rare earth carbides and specific isotopic labeling.

Email: [info@benchchem.com](mailto:info@benchchem.com) or [Request Quote Online](#).

## References

- 1. [benchchem.com](https://www.benchchem.com) [benchchem.com]

- [2. promega.com \[promega.com\]](#)
- [3. benchchem.com \[benchchem.com\]](#)
- [4. indigobiosciences.com \[indigobiosciences.com\]](#)
- [5. Monitor NF- \$\kappa\$ B activation with dual luciferase reporter assay on SpectraMax iD5 \[moleculardevices.com\]](#)
- [6. mdpi.com \[mdpi.com\]](#)
- To cite this document: BenchChem. [Application Notes and Protocols for Testing Arzanol's Anti-inflammatory Activity]. BenchChem, [2026]. [Online PDF]. Available at: [<https://www.benchchem.com/product/b15073832/docs#application-notes-and-protocols-for-testing-arzanol-s-anti-inflammatory-activity>]

---

### Disclaimer & Data Validity:

The information provided in this document is for Research Use Only (RUO) and is strictly not intended for diagnostic or therapeutic procedures. While BenchChem strives to provide accurate protocols, we make no warranties, express or implied, regarding the fitness of this product for every specific experimental setup.

**Technical Support:** The protocols provided are for reference purposes. Unsure if this reagent suits your experiment?

**Need Industrial/Bulk Grade?** [Request Custom Synthesis Quote](#)

## BenchChem

Our mission is to be the trusted global source of essential and advanced chemicals, empowering scientists and researchers to drive progress in science and industry.

### Contact

Address: 3281 E Guasti Rd

Ontario, CA 91761, United States

Phone: (601) 213-4426

Email: [info@benchchem.com](mailto:info@benchchem.com)

Contact our Ph.D. Support Team for a compatibility check