

Application Note: Orthogonal Functionalization Strategies for N4/N7 Diazaspiro Scaffolds

Author: BenchChem Technical Support Team. **Date:** April 2026

Compound of Interest

Compound Name: *(R)*-5-Methyl-4,7-diazaspiro[2.5]octan-6-one

Cat. No.: B15072436

[Get Quote](#)

Introduction: The "Escape from Flatland"

Diazaspiro cycles are critical "Fsp³-rich" scaffolds in modern drug discovery, offering defined exit vectors that improve solubility and metabolic stability compared to flat aromatic heterocycles. However, their utility is often bottlenecked by the difficulty in differentiating the two nitrogen atoms (e.g., N4 and N7), which are often both secondary amines with similar pK_a values.

This guide details three strategies to break this symmetry:

- Steric Differentiation: Exploiting the local environment (e.g., spiro-center proximity).
- Electronic Modulation: Leveraging subtle pK_a differences between ring sizes (e.g., azetidine vs. piperidine).
- Thermal/Kinetic Control: Using temperature to control reaction rates at the more nucleophilic center.

Strategic Framework

Strategy A: pKa and Nucleophilicity-Driven Selectivity

In asymmetric spiro systems (e.g., [3.5] or [2.5] rings), the nitrogen atoms reside in rings of different strain.

- **Smaller Rings (3-4 membered):** The nitrogen often exhibits higher s-character in its lone pair (due to ring strain), potentially lowering nucleophilicity compared to unstrained rings, despite similar basicity.
- **Larger Rings (5-6 membered):** Typically display "standard" secondary amine nucleophilicity.

Rule of Thumb: Under kinetic control (low temp, stoichiometric reagent), electrophiles (Boc₂O, Cbz-Cl) preferentially react with the nitrogen in the larger, less strained ring (e.g., N7 in a [2.5] system) or the position furthest from the sterically demanding spiro-center.

Strategy B: The "Temporary Silicon" Mask

For scenarios where direct differentiation is difficult, a "double protection / single deprotection" strategy is robust.

- Global protection (e.g., bis-benylation).
- Selective deprotection (e.g., ACE-Cl or hydrogenation) based on steric accessibility.

Experimental Protocols

Protocol 1: Kinetic Separation via Selective Boc-Protection

Target: Selective protection of the less hindered amine (typically N7 in [2.5] or [3.5] systems).

Materials:

- Diazaspiro diamine (1.0 equiv)
- Boc-anhydride (0.95 equiv) — Crucial: use slight deficit to prevent bis-protection.
- Triethylamine (TEA) (1.5 equiv)

- Dichloromethane (DCM) (Anhydrous)

Procedure:

- Dissolution: Dissolve the diazaspino diamine (10 mmol) in anhydrous DCM (50 mL) and cool to -78°C (dry ice/acetone bath).
 - Why: Low temperature maximizes the kinetic difference between the two amines.
- Addition: Add TEA (15 mmol). Then, add Boc₂O (9.5 mmol) dissolved in DCM (10 mL) dropwise over 1 hour.
 - Why: Slow addition ensures the concentration of electrophile remains low, favoring the most reactive amine.
- Equilibration: Allow the mixture to stir at -78°C for 2 hours, then slowly warm to 0°C over 4 hours. Do not warm to room temperature immediately.
- Quench & Workup: Quench with water (20 mL). Extract with DCM (3x). Wash organics with brine, dry over Na₂SO₄.
- Purification: The crude will contain mostly mono-Boc (N7) and unreacted starting material. Bis-Boc is minimized. Separate via flash chromatography (MeOH/DCM gradient).

Protocol 2: Orthogonal Arylation (SNAr)

Target: Installing a heteroaryl group on the more nucleophilic nitrogen (N7) while leaving N4/N2 free.

Materials:

- Diazaspino scaffold (1.0 equiv)
- 2-Chloropyrimidine or similar SNAr electrophile (1.0 equiv)
- DIPEA (2.5 equiv)
- DMSO or NMP (Polar aprotic solvent promotes SNAr)

Procedure:

- Setup: Mix diazaspiro diamine (1.0 equiv) and DIPEA (2.5 equiv) in DMSO (0.2 M concentration).
- Reaction: Add the heteroaryl chloride (1.0 equiv) at Room Temperature (RT).
- Monitoring: Monitor by LCMS.
 - Observation: The less hindered/more nucleophilic nitrogen (N7) typically reacts within 1-4 hours at RT. The hindered nitrogen (N4/N2) usually requires heating (>80°C) to react.
- Stop Point: Quench immediately upon consumption of the electrophile to prevent bis-arylation.

Data Summary: Reactivity Profiles

Variable	N4/N2 Position (Small/Hindered Ring)	N7 Position (Large/Exposed Ring)	Recommended Strategy
Ring Size	Typically 3 or 4- membered	Typically 5 or 6- membered	--
Steric Bulk	High (Proximal to Spiro center)	Low (Distal)	Target N7 first with bulky groups.
Nucleophilicity	Moderate to Low	High	N7 reacts faster with alkyl halides/anhydrides.
pKa (Approx)	~9.5 - 10.5	~10.5 - 11.2	Use pH-controlled extraction to separate isomers.
SNAr Reactivity	Requires Heat (>80°C)	Reacts at RT	Perform SNAr at RT to selective tag N7.

Visualizing the Workflow

The following diagrams illustrate the decision logic for functionalizing these scaffolds.

Diagram 1: Strategic Decision Tree

This flowchart guides the chemist through selecting the correct pathway based on the desired final substitution pattern.

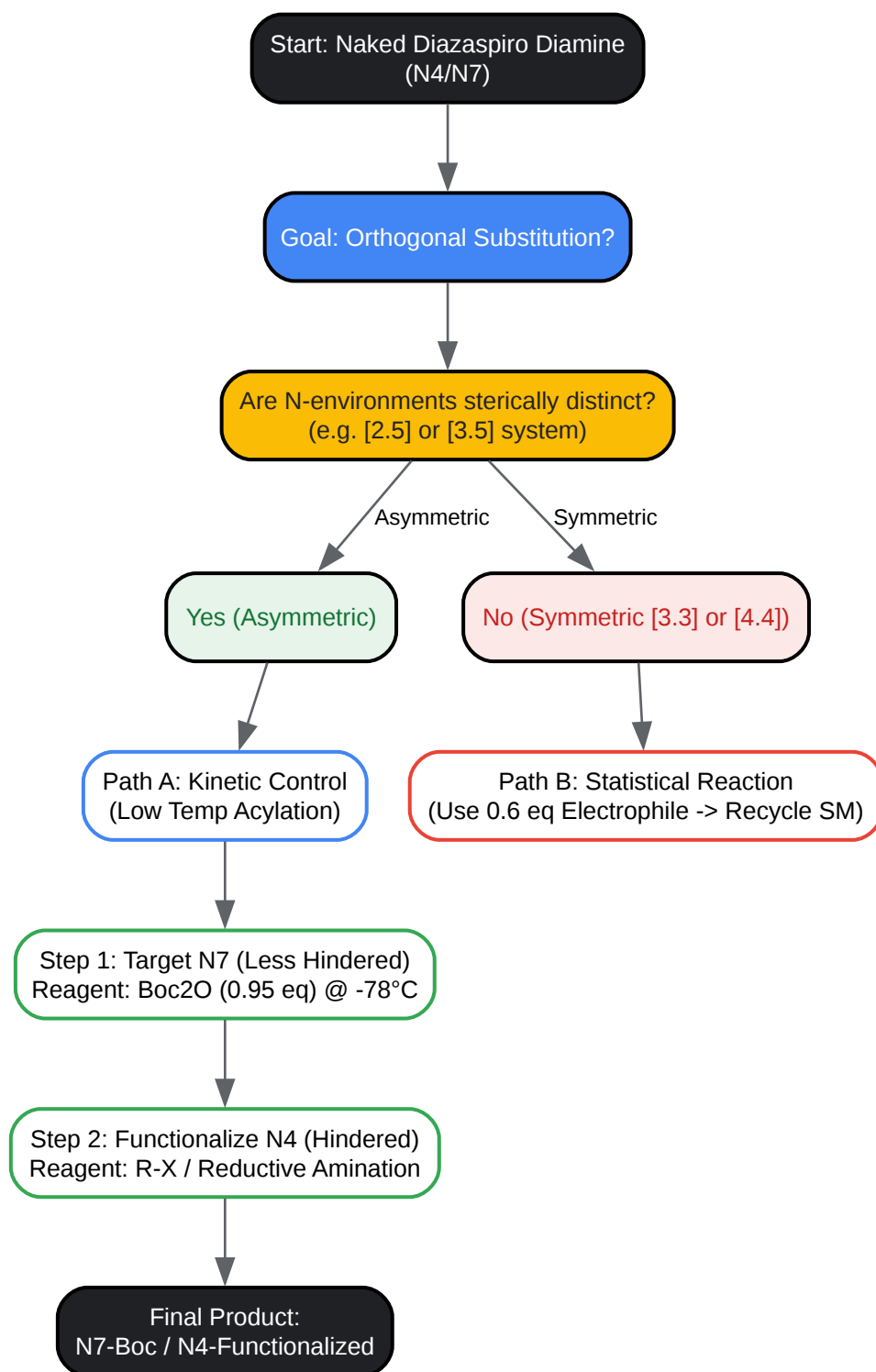

[Click to download full resolution via product page](#)

Caption: Decision matrix for selecting kinetic vs. statistical functionalization routes based on scaffold symmetry.

Diagram 2: Synthetic Workflow for N7-Selective Arylation

A specific protocol visualization for installing a heteroaryl group on N7 followed by N4 diversification.

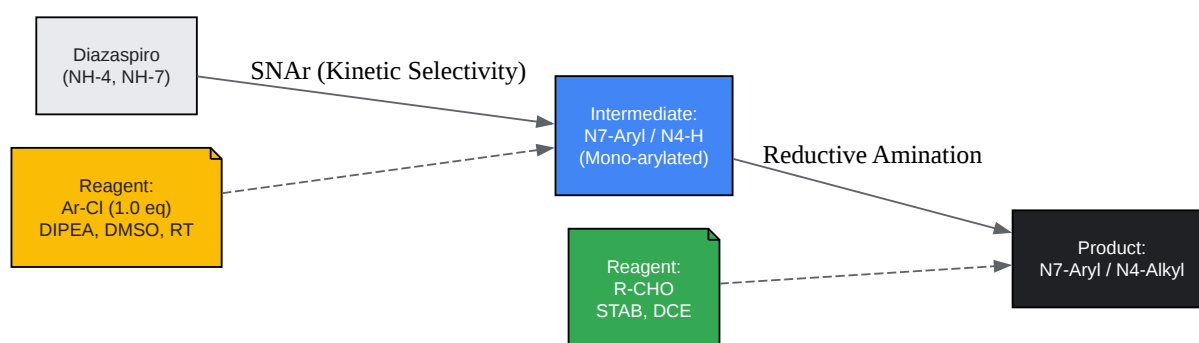

[Click to download full resolution via product page](#)

Caption: Step-wise protocol for N7-selective SNAr followed by N4-reductive amination.

References

- Burkhard, J. A., et al. (2010). Synthesis and Structural Analysis of 2-Azaspiro[3.3]heptanes as Piperidine Surrogates. *Organic Letters*. [Link](#)
- Wuitschik, G., et al. (2010). Spirocyclic Scaffolds in Medicinal Chemistry: Evaluation of Physical Properties and Metabolic Stability. *Journal of Medicinal Chemistry*. [Link](#)
- PubChem Compound Summary. (2025). 4,7-Diazaspiro[2.5]octane and related spiro-systems. National Library of Medicine. [Link](#)
- Mykhailiuk, P. K. (2019). Saturated Bioisosteres of Benzene: Where to Go Next? *Organic & Biomolecular Chemistry*.^{[1][2][3]} [Link](#)
- BenchChem Technical Notes. (2025). Regioselective Functionalization of 7-Azaspiro[3.5]nonane.^[4][Link](#)

Need Custom Synthesis?

BenchChem offers custom synthesis for rare earth carbides and specific isotopic labeling.

Email: info@benchchem.com or [Request Quote Online](#).

Sources

- [1. pdf.benchchem.com \[pdf.benchchem.com\]](https://pdf.benchchem.com)
- [2. Orthogonally Protected Furanoid Sugar Diamino Acids for Solid-Phase Synthesis of Oligosaccharide Mimetics - PubMed \[pubmed.ncbi.nlm.nih.gov\]](#)
- [3. Selecting Orthogonal Building Blocks \[sigmaaldrich.com\]](#)
- [4. fujc.pp.ua \[fujc.pp.ua\]](#)
- To cite this document: BenchChem. [Application Note: Orthogonal Functionalization Strategies for N4/N7 Diazaspiro Scaffolds]. BenchChem, [2026]. [Online PDF]. Available at: [\[https://www.benchchem.com/product/b15072436/docs#application-note-orthogonal-functionalization-strategies-for-n4-n7-diazaspiro-scaffolds\]](https://www.benchchem.com/product/b15072436/docs#application-note-orthogonal-functionalization-strategies-for-n4-n7-diazaspiro-scaffolds)

Disclaimer & Data Validity:

The information provided in this document is for Research Use Only (RUO) and is strictly not intended for diagnostic or therapeutic procedures. While BenchChem strives to provide accurate protocols, we make no warranties, express or implied, regarding the fitness of this product for every specific experimental setup.

Technical Support: The protocols provided are for reference purposes. Unsure if this reagent suits your experiment?

Need Industrial/Bulk Grade? [Request Custom Synthesis Quote](#)

BenchChem

Our mission is to be the trusted global source of essential and advanced chemicals, empowering scientists and researchers to drive progress in science and industry.

Contact

Address: 3281 E Guasti Rd

Ontario, CA 91761, United States

Phone: (601) 213-4426

Email: info@benchchem.com

[Contact our Ph.D. Support Team for a compatibility check](#)