

Application Note: Advanced Synthetic Architectures for Bioactive Quinoline Derivatives

Author: BenchChem Technical Support Team. **Date:** April 2026

Compound of Interest

Compound Name: 2-(Quinolin-2-yl)acetaldehyde

Cat. No.: B15071258

[Get Quote](#)

Abstract

The quinoline scaffold remains a "privileged structure" in medicinal chemistry, serving as the pharmacophore for antimalarials (Chloroquine), kinase inhibitors (Lenvatinib), and antibacterials (Ciprofloxacin). This guide moves beyond textbook definitions to provide industrial-grade synthetic protocols. We focus on three distinct methodologies: a modernized classical condensation for scalability, a transition-metal-catalyzed C-H activation for late-stage functionalization, and a green multicomponent reaction for diversity-oriented synthesis (DOS).

Part 1: Strategic Retrosynthesis & Design

The selection of a synthetic route must be dictated by the target's substitution pattern. "One-size-fits-all" chemistry fails in modern SAR (Structure-Activity Relationship) studies.

- C2/C3 Substitution: Best accessed via Friedländer or Povarov methodologies.
- C4 Functionalization: Best accessed via Conrad-Limpach or Gould-Jacobs (followed by chlorination/SNAr).

- C8 Functionalization: Best accessed via C-H Activation using directing groups.[1][2]

Visualization: Strategic Synthetic Map

The following diagram maps precursor selection to the optimal synthetic pathway.

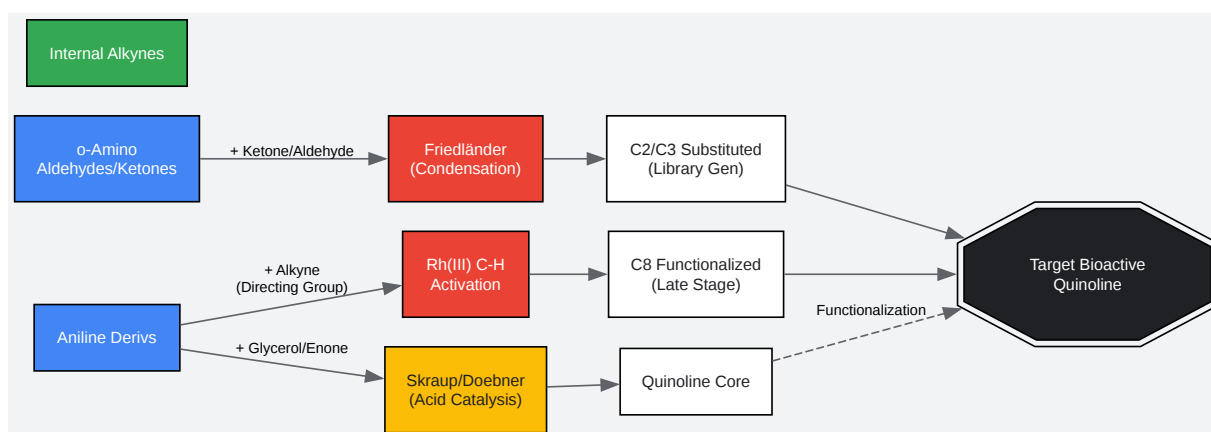

[Click to download full resolution via product page](#)

Caption: Decision tree for selecting synthetic pathways based on the desired substitution pattern of the quinoline core.

Part 2: Experimental Protocols

Protocol A: Optimized Friedländer Annulation (Scalable)

Application: Generation of C2/C3-substituted quinoline libraries (e.g., for GPCR ligands).

Mechanism: Base-catalyzed aldol condensation followed by cyclodehydration.

Reagents & Equipment[1][3][4][5][6][7]

- Substrate 1: 2-Aminoaryl ketone (e.g., 2-aminobenzophenone).
- Substrate 2:

-Methylene ketone (e.g., cyclohexanone or acetophenone).

- Catalyst: KOH (pellets, crushed) or saturated ethanolic KOH.
- Solvent: Absolute Ethanol (EtOH).
- Equipment: Microwave reactor (optional for speed) or standard reflux setup.

Step-by-Step Methodology

- Stoichiometry Setup: In a 50 mL round-bottom flask, dissolve 2-aminoaryl ketone (1.0 equiv, 5 mmol) in absolute EtOH (15 mL).
- Catalyst Addition: Add the
 - methylene ketone (1.2 equiv).^[5] Add solid KOH (0.2 equiv) directly to the solution.
 - Critical Process Parameter (CPP): Do not use excess base if the substrate contains base-sensitive esters. For sensitive substrates, switch to piperidine (catalytic drops).
- Reaction: Reflux at 80°C for 3–6 hours.
 - Self-Validation: Monitor via TLC (30% EtOAc/Hexane). The disappearance of the fluorescent amine spot (starting material) and the appearance of a new, highly fluorescent spot (quinoline) confirms progress.
- Workup: Cool to room temperature. Pour the mixture into crushed ice (50 g) with vigorous stirring.
- Isolation: The product often precipitates as a solid.^[7] Filter, wash with cold water (3x), and dry. If oil forms, extract with DCM, dry over MgSO₄, and concentrate.
- Yield Expectation: 85–95%.

Protocol B: Rh(III)-Catalyzed C-H Activation/Annulation

Application: High-value, atom-economical synthesis of quinolines from anilines and alkynes. Ideal for "scaffold hopping" in drug discovery. Mechanism: C-H activation directed by an oxidizing directing group (e.g., N-oxide or amide), alkyne insertion, and reductive elimination.

Reagents & Equipment[1][3][4][5][6][7]

- Substrate: N-Methoxybenzamide (Directing Group substrate) or Aniline.
- Coupling Partner: Internal alkyne (e.g., diphenylacetylene).
- Catalyst:

(Pentamethylcyclopentadienyl rhodium dichloride dimer).
- Oxidant/Additive:

(Silver hexafluoroantimonate) and

.
- Solvent: t-Amyl alcohol or DCE.

Workflow Visualization

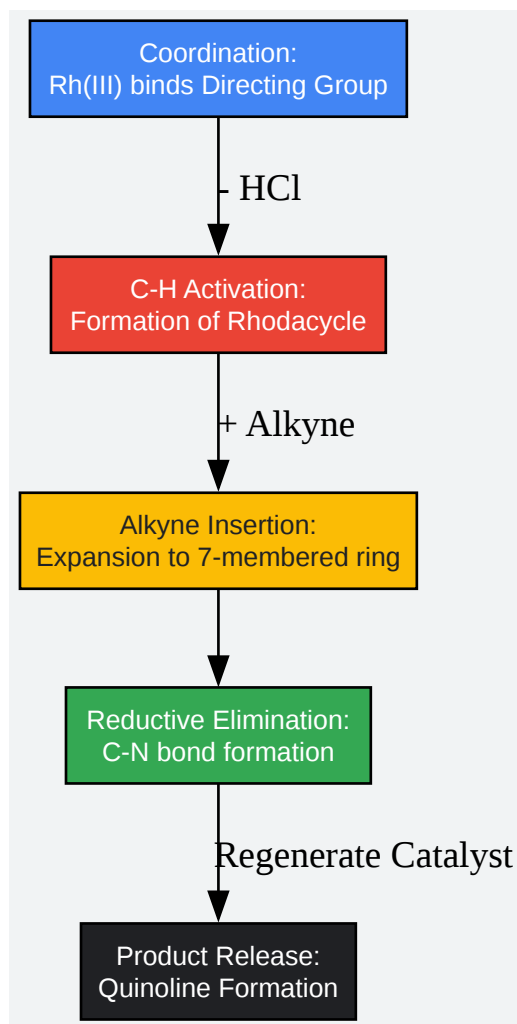

[Click to download full resolution via product page](#)

Caption: Mechanistic cycle of Rh(III)-catalyzed quinoline synthesis via C-H activation.

Step-by-Step Methodology

- **Glovebox/Schlenk Prep:** In a dried screw-cap pressure tube, combine the aniline derivative (0.2 mmol), alkyne (0.24 mmol), (2.5 mol%), and (2.1 equiv).
- **Solvent Addition:** Add t-Amyl alcohol (2.0 mL) under atmosphere.

- Thermal Activation: Seal the tube and heat to 110°C for 16 hours.
 - Why this temp? High temperature is required to overcome the energy barrier for the C-H cleavage step (the rate-determining step).
- Filtration: Cool to RT. Dilute with DCM and filter through a short pad of Celite to remove metal salts.
- Purification: Concentrate filtrate and purify via flash chromatography (Gradient: 0-20% EtOAc in Hexanes).

Protocol C: Green Microwave-Assisted Multicomponent Synthesis

Application: Rapid generation of tetrahydroquinolines (which can be oxidized to quinolines) for diversity libraries. Green Metrics: Solvent-free or water-based, high atom economy.

Reagents

- Components: Aniline (1 equiv), Benzaldehyde derivative (1 equiv), Styrene or Vinyl ether (1 equiv).
- Catalyst:

(Indium trichloride) or

(Scandium triflate) - Lewis Acids tolerant of water.
- Solvent: Water or Acetonitrile.

Step-by-Step Methodology

- Mixing: In a microwave vial, mix aniline (1.0 mmol), aldehyde (1.0 mmol), and alkene (1.0 mmol) in water (2 mL).
- Catalysis: Add

(10 mol%).
- Irradiation: Microwave at 100°C for 15 minutes (Power: 150W).

- Comparison: Conventional heating would require 12+ hours reflux.
- Extraction: Extract with Ethyl Acetate.
- Oxidation (Optional): To convert the tetrahydroquinoline to fully aromatic quinoline, treat the crude product with DDQ (2,3-Dichloro-5,6-dicyano-1,4-benzoquinone) in Toluene at RT for 1 hour.

Part 3: Data Summary & Troubleshooting

Comparative Efficiency Table

Methodology	Atom Economy	Reaction Time	Scalability	Key Limitation
Friedländer	Moderate (-)	3–6 hrs	High (kg scale)	Requires specific o-amino ketone precursors.
Rh(III) C-H	High	16–24 hrs	Low (mg scale)	High cost of catalyst; requires inert atmosphere.
Povarov (MCR)	Very High	15 min (MW)	Medium	Stereocontrol can be difficult; produces tetrahydro- core initially.

Troubleshooting Guide

- Problem: Low yield in Friedländer reaction.
 - Solution: Check the freshness of the o-amino ketone. These oxidize easily. Recrystallize precursor if dark. Ensure conditions are strictly anhydrous if using alkoxide bases.
- Problem: Regioselectivity issues in C-H activation.

- Solution: Use a stronger directing group (e.g., pivalamide) or switch solvent to TFE (Trifluoroethanol) to alter the transition state energetics.

References

- Sharma, S., et al. (2023).[8] "Synthetic Strategies for Quinoline Based Derivatives as Potential Bioactive Heterocycles." *Current Organic Synthesis*, 20(6).
- Wang, X., et al. (2022).[9][10] "Ruthenium-catalyzed aza-Michael addition and intramolecular annulation of enaminones with anthranils." *Organic Chemistry Frontiers*.
- BenchChem. (2025).[1][5][7] "Application Notes and Protocols for C–H Activation in Quinoline Synthesis." *BenchChem Technical Library*.
- Maddila, S., et al. (2020). "Recent advances in the synthesis of quinoline derivatives via multicomponent reactions." *Synthetic Communications*.
- Alfa Chemistry. (2024). "Friedländer Quinoline Synthesis Protocol." *Alfa Chemistry Knowledge Base*.

Need Custom Synthesis?

BenchChem offers custom synthesis for rare earth carbides and specific isotopic labeling.

Email: info@benchchem.com or [Request Quote Online](#).

Sources

- 1. pdf.benchchem.com [pdf.benchchem.com]
- 2. pubs.acs.org [pubs.acs.org]
- 3. pdf.benchchem.com [pdf.benchchem.com]
- 4. [Quinoline Synthesis: Nanocatalyzed Green Protocols—An Overview - PMC](#) [[pmc.ncbi.nlm.nih.gov](https://pubmed.ncbi.nlm.nih.gov/)]
- 5. benchchem.com [benchchem.com]
- 6. pdf.benchchem.com [pdf.benchchem.com]
- 7. pdf.benchchem.com [pdf.benchchem.com]

- [8. benthamdirect.com](https://benthamdirect.com) [benthamdirect.com]
- [9. mdpi.com](https://mdpi.com) [mdpi.com]
- [10. researchgate.net](https://researchgate.net) [researchgate.net]
- To cite this document: BenchChem. [Application Note: Advanced Synthetic Architectures for Bioactive Quinoline Derivatives]. BenchChem, [2026]. [Online PDF]. Available at: [<https://www.benchchem.com/product/b15071258/docs#application-note-advanced-synthetic-architectures-for-bioactive-quinoline-derivatives>]

Disclaimer & Data Validity:

The information provided in this document is for Research Use Only (RUO) and is strictly not intended for diagnostic or therapeutic procedures. While BenchChem strives to provide accurate protocols, we make no warranties, express or implied, regarding the fitness of this product for every specific experimental setup.

Technical Support: The protocols provided are for reference purposes. Unsure if this reagent suits your experiment?

Need Industrial/Bulk Grade? [Request Custom Synthesis Quote](#)

BenchChem

Our mission is to be the trusted global source of essential and advanced chemicals, empowering scientists and researchers to drive progress in science and industry.

Contact

Address: 3281 E Guasti Rd
Ontario, CA 91761, United States
Phone: (601) 213-4426
Email: info@benchchem.com

[Contact our Ph.D. Support Team for a compatibility check](#)

