

Technical Whitepaper: 2-Chloroethoxymethyl Acetate (CEM-OAc)

Author: BenchChem Technical Support Team. **Date:** April 2026

Compound of Interest

Compound Name: 2-Chloroethoxymethyl acetate

Cat. No.: B15062920

[Get Quote](#)

Executive Summary

2-Chloroethoxymethyl acetate (CAS 89181-29-3) is a specialized organochlorine reagent used primarily in organic synthesis as a precursor for the 2-chloroethoxymethyl (CEM) protecting group. Unlike its more volatile and unstable counterpart, 2-chloroethoxymethyl chloride (CEM-Cl), the acetate derivative offers enhanced stability and handling characteristics while retaining high reactivity under Lewis acid catalysis.

This guide provides a comprehensive technical analysis of **2-chloroethoxymethyl acetate**, detailing its chemical identity, mechanism of action, synthesis protocols, and applications in drug development, particularly in nucleoside and carbohydrate chemistry.

Part 1: Chemical Identity & Properties[1][2]

Nomenclature and Identifiers

The precise identification of this compound is critical due to the existence of structurally similar isomers (e.g., methyl 2-(2-chloroethoxy)acetate, CAS 83881-47-4). Researchers must verify the structure $\text{AcO-CH}_2\text{-O-CH}_2\text{CH}_2\text{Cl}$ to ensure the correct reagent is selected for etherification/protection reactions.

Property	Details
Chemical Name	2-Chloroethoxymethyl acetate
CAS Number	89181-29-3
Synonyms	Acetoxymethyl 2-chloroethyl ether; (2-Chloroethoxy)methyl acetate; CEM-Acetate
Molecular Formula	C ₅ H ₉ ClO ₃
Molecular Weight	152.58 g/mol
SMILES	CC(=O)OCCCl
InChI Key	AOZMJKVQCFCLKQ-UHFFFAOYSA-N
Structure	Acetate ester of a hemiacetal: CH ₃ -C(=O)-O-CH ₂ -O-CH ₂ -CH ₂ -Cl

Physical Properties[3]

- Appearance: Colorless to pale yellow liquid.
- Solubility: Soluble in polar organic solvents (Dichloromethane, THF, Ethyl Acetate); hydrolyzes in water.
- Stability: More stable than the corresponding chloromethyl ether (CEM-Cl) but sensitive to moisture and strong acids. Store under inert atmosphere (Argon/Nitrogen) at 2–8°C.

Part 2: Mechanistic Role & Reactivity

The CEM Protecting Group

The 2-chloroethoxymethyl (CEM) group is an acetal-type protecting group for hydroxyl moieties. It is structurally related to the MEM (2-methoxyethoxymethyl) group but contains a terminal chlorine atom. This chlorine handle allows for specific post-synthetic modifications or unique deprotection conditions (e.g., reductive cleavage) that are orthogonal to standard acid-labile groups.

Mechanism of Activation

2-Chloroethoxymethyl acetate acts as a "CEM donor." It is an acetal ester that, upon activation by a Lewis acid, generates a highly electrophilic oxocarbenium ion. This species reacts with nucleophiles (alcohols) to form the stable CEM ether.

Key Advantages over CEM-Cl:

- Safety: CEM-Cl is a potent alkylating agent and a suspected carcinogen (like MOM-Cl). The acetate precursor is less volatile and safer to handle.
- Controlled Reactivity: The acetate requires Lewis acid activation (e.g., $\text{BF}_3 \cdot \text{OEt}_2$ / TMSOTf), allowing for better control over reaction kinetics compared to the highly reactive chloride.

Reaction Pathway Diagram

The following diagram illustrates the activation of CEM-OAc and the subsequent protection of an alcohol.

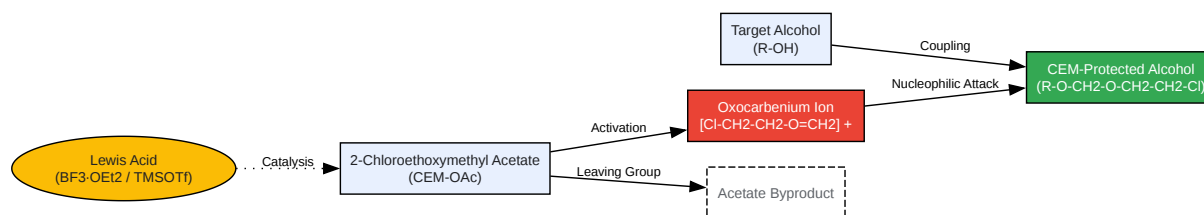

[Click to download full resolution via product page](#)

Figure 1: Mechanism of Lewis acid-catalyzed alcohol protection using **2-Chloroethoxymethyl acetate**.

Part 3: Synthesis & Experimental Protocols

Synthesis of 2-Chloroethoxymethyl Acetate

Two primary routes exist for synthesizing this reagent. The Salt Metathesis Route is preferred for high purity, while the One-Pot Acetalization is more direct from commodity chemicals.

Protocol A: Salt Metathesis (From CEM-Cl)

This method converts the unstable chloride to the stable acetate.

Reagents:

- 2-Chloroethoxymethyl chloride (CEM-Cl)
- Sodium Acetate (Anhydrous)[1]
- Solvent: DMF or Acetone

Step-by-Step Methodology:

- Preparation: Flame-dry a round-bottom flask and purge with Argon.
- Dissolution: Suspend anhydrous Sodium Acetate (1.2 equiv) in dry DMF.
- Addition: Cool the mixture to 0°C. Add CEM-Cl (1.0 equiv) dropwise via syringe to control the exotherm.
- Reaction: Allow the mixture to warm to room temperature and stir for 4–6 hours. Monitor by TLC (or NMR aliquot).
- Workup: Dilute with diethyl ether, wash with water (3x) to remove DMF and salts, and wash with brine.
- Purification: Dry organic layer over
 , filter, and concentrate in vacuo. Distillation under reduced pressure yields pure CEM-OAc.
 [2]

Protocol B: One-Pot Acetalization (From 2-Chloroethanol)

A direct synthesis utilizing paraformaldehyde and acetic anhydride.

Reagents:

- 2-Chloroethanol[3][4][5][6][7][8]
- Paraformaldehyde
- Acetic Anhydride[1][9]
- Catalyst:
or similar Lewis acid

Step-by-Step Methodology:

- Mixing: Combine 2-chloroethanol (1.0 equiv) and paraformaldehyde (1.1 equiv) in a flask.
- Acylation: Add acetic anhydride (1.2 equiv) and a catalytic amount of fused
.
- Heating: Heat the mixture to 70–80°C for 2–4 hours. The paraformaldehyde will dissolve as the reaction proceeds.
- Isolation: Fractional distillation of the reaction mixture yields **2-chloroethoxymethyl acetate**.

Application: Protection of a Nucleoside (5'-OH)

This protocol demonstrates the use of CEM-OAc to protect the 5'-hydroxyl group of a nucleoside.

Workflow Diagram:

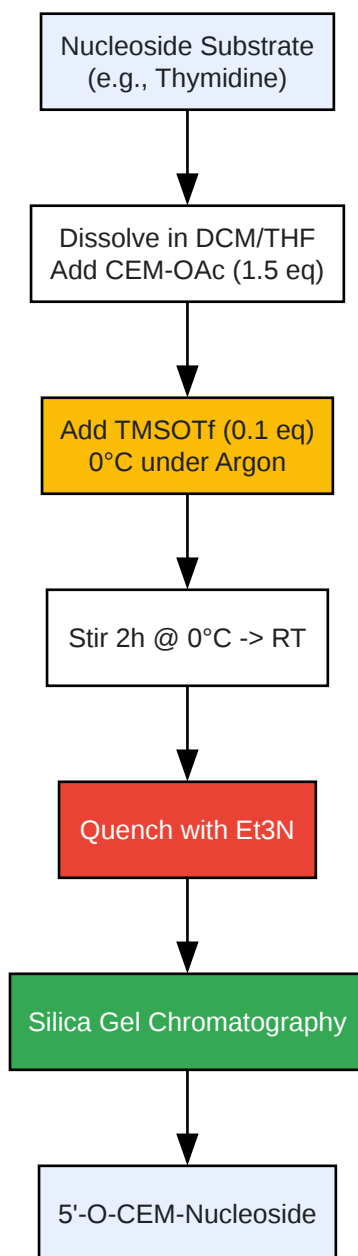

[Click to download full resolution via product page](#)

Figure 2: Workflow for the protection of nucleoside hydroxyls using CEM-OAc.

Part 4: Safety & Handling

- Hazards: **2-Chloroethoxymethyl acetate** is an alkylating agent. It is potentially carcinogenic and mutagenic. It may hydrolyze to release formaldehyde and 2-chloroethanol.

- PPE: Wear chemical-resistant gloves (nitrile/butyl), safety goggles, and a lab coat. Always handle inside a fume hood.
- Decontamination: Spills should be treated with aqueous ammonia or dilute sodium hydroxide to hydrolyze the ester and neutralize the alkylating potential.

References

- Google Patents. CN1030607C - Synthesis for the preparation of tetracyclic compounds. (Lists **2-chloroethoxymethyl acetate** as an intermediate).
- LookChem. 2-(2-chloroethoxy) methyl acetate CAS 83881-47-4 vs 89181-29-3. (Differentiation of isomers). Retrieved from [\[Link\]](#)
- Tomozawa, T., et al. (2013). "Chemical synthesis of a very long oligoribonucleotide with 2-cyanoethoxymethyl (CEM) as the 2'-O-protecting group".[\[10\]](#) Nucleic Acids Research.[\[10\]](#) (Contextual reference for CEM protecting group chemistry). Retrieved from [\[Link\]](#)
- Greene, T. W., & Wuts, P. G. M. Protective Groups in Organic Synthesis. (General reference for acetal protecting groups).

Need Custom Synthesis?

BenchChem offers custom synthesis for rare earth carbides and specific isotopic labeling.

Email: info@benchchem.com or [Request Quote Online](#).

Sources

- [1. Organic Syntheses Procedure \[orgsyn.org\]](#)
- [2. pdf.benchchem.com \[pdf.benchchem.com\]](#)
- [3. CN101844978A - Synthesis method of 2-\(2-chloroethoxy\) acetic acid - Google Patents \[patents.google.com\]](#)
- [4. scribd.com \[scribd.com\]](#)
- [5. Ethanol, 2-chloro-, acetate \[webbook.nist.gov\]](#)
- [6. CN101665415A - Preparation method of 2-\(2-chloroethyl\) ethanol - Google Patents \[patents.google.com\]](#)

- [7. A Process For Preparing 2\(2 Chloroethoxy\) Ethanol. \[quickcompany.in\]](#)
- [8. Preparation method of 2-chloroethoxy-2-ethoxyethanol - Eureka | Patsnap \[eureka.patsnap.com\]](#)
- [9. discovery.researcher.life \[discovery.researcher.life\]](#)
- [10. Chemical synthesis of a very long oligoribonucleotide with 2-cyanoethoxymethyl \(CEM\) as the 2'-O-protecting group: structural identification and biological activity of a synthetic 110mer precursor-microRNA candidate - PMC \[pmc.ncbi.nlm.nih.gov\]](#)
- To cite this document: BenchChem. [Technical Whitepaper: 2-Chloroethoxymethyl Acetate (CEM-OAc)]. BenchChem, [2026]. [Online PDF]. Available at: [\[https://www.benchchem.com/product/b15062920/docs#technical-whitepaper-2-chloroethoxymethyl-acetate-cem-oac\]](https://www.benchchem.com/product/b15062920/docs#technical-whitepaper-2-chloroethoxymethyl-acetate-cem-oac)

Disclaimer & Data Validity:

The information provided in this document is for Research Use Only (RUO) and is strictly not intended for diagnostic or therapeutic procedures. While BenchChem strives to provide accurate protocols, we make no warranties, express or implied, regarding the fitness of this product for every specific experimental setup.

Technical Support: The protocols provided are for reference purposes. Unsure if this reagent suits your experiment?

Need Industrial/Bulk Grade? [Request Custom Synthesis Quote](#)

BenchChem

Our mission is to be the trusted global source of essential and advanced chemicals, empowering scientists and researchers to drive progress in science and industry.

Contact

Address: 3281 E Guasti Rd
Ontario, CA 91761, United States
Phone: (601) 213-4426
Email: info@benchchem.com

Contact our Ph.D. Support Team for a compatibility check