

# Application Note: Precision Microwave-Assisted Synthesis of 1,2,4-Oxadiazole Derivatives

**Author:** BenchChem Technical Support Team. **Date:** May 2026

## Compound of Interest

Compound Name: (3-Ethyl-1,2,4-oxadiazol-5-  
YL)methanol

CAS No.: 959237-62-8

Cat. No.: B1506632

[Get Quote](#)

## Executive Summary

The 1,2,4-oxadiazole ring is a privileged scaffold in medicinal chemistry, serving as a bioisostere for esters and amides with improved metabolic stability and lipophilicity. Conventional thermal synthesis of this moiety often suffers from prolonged reaction times (12–48 hours), harsh conditions, and difficult purification steps due to the formation of O-acylamidoxime intermediates that resist cyclization.

This guide details a Microwave-Assisted Organic Synthesis (MAOS) protocol that reduces reaction times to under 20 minutes while significantly enhancing yield and purity. We focus on a "One-Pot, Two-Step" condensation of amidoximes with carboxylic acids, utilizing polymer-supported reagents to facilitate rapid workup—ideal for high-throughput library generation in drug discovery.

## Mechanistic Insight & Scientific Rationale

### The Challenge of Cyclodehydration

The formation of 1,2,4-oxadiazoles from carboxylic acids and amidoximes proceeds through two distinct stages:

- O-Acylation: The carboxylic acid is activated (e.g., by HBTU, CDI, or T3P) and attacked by the oxygen of the amidoxime to form an O-acylamidoxime intermediate.
- Cyclodehydration: This rate-determining step requires the elimination of water to close the ring. Under thermal conditions, this often requires high temperatures (>100°C) which can degrade sensitive functional groups.

## The Microwave Advantage

Microwave irradiation provides direct dielectric heating, coupling efficiently with polar solvents (e.g., DMF, MeCN) and the polar transition state of the cyclization. This "superheating" effect overcomes the activation energy barrier of the dehydration step almost instantaneously, preventing the accumulation of the thermally unstable O-acylamidoxime intermediate.

## Reaction Mechanism Diagram

The following diagram illustrates the pathway from activation to cyclization.[1]

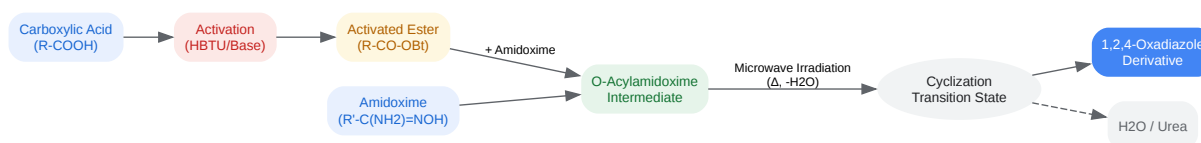

[Click to download full resolution via product page](#)

Figure 1: Mechanistic pathway of 1,2,4-oxadiazole formation via O-acylamidoxime dehydration. [2]

## Experimental Protocols

### Protocol A: Polymer-Supported High-Throughput Synthesis

Best for: Library generation, high purity requirements, avoiding aqueous workup. Chemistry: HBTU coupling with Polymer-Supported BEMP (PS-BEMP) base.

## Materials

- Carboxylic Acid: 1.0 equiv (0.5 mmol)
- Amidoxime: 1.1 equiv (0.55 mmol)
- Coupling Reagent: HBTU (1.1 equiv)
- Base: PS-BEMP (2-tert-butylimino-2-diethylamino-1,3-dimethylperhydro-1,3,2-diazaphosphorine on polystyrene), 3.0 equiv.
- Solvent: Acetonitrile (MeCN) or MeCN/DMF (4:1).
- Vessel: 10 mL microwave-transparent sealed tube.

## Workflow Diagram

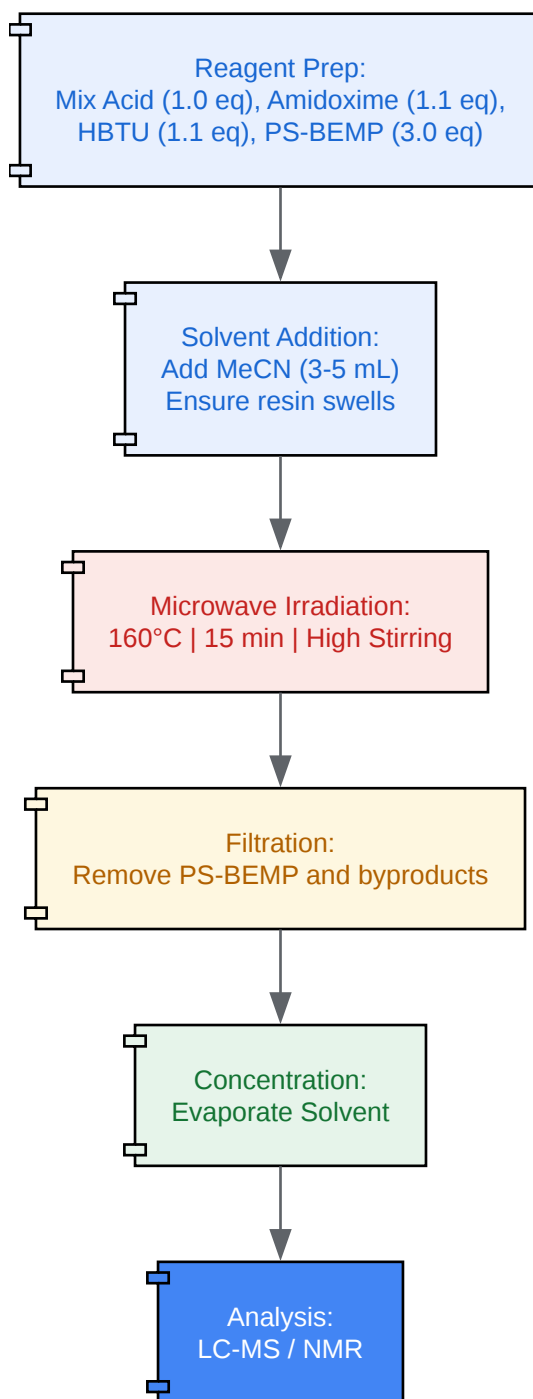

[Click to download full resolution via product page](#)

Figure 2: Workflow for polymer-supported microwave synthesis.

## Step-by-Step Procedure

- Charge Vessel: In a 10 mL microwave vial, add the carboxylic acid (0.5 mmol), amidoxime (0.55 mmol), and HBTU (0.55 mmol).

- Add Base: Add PS-BEMP resin (approx. 1.5 mmol loading).[3] Note: PS-BEMP acts as both a base and a scavenger for acidic byproducts.
- Solvation: Add 3–4 mL of anhydrous Acetonitrile. If reagents are not fully soluble, add up to 20% DMF.[4]
- Irradiation: Seal the vial. Program the microwave reactor:
  - Temperature: 160°C
  - Hold Time: 15 minutes
  - Pressure Limit: 250 psi (17 bar)
  - Power: Dynamic (Max 200W)
  - Stirring: High (critical for resin suspension)
- Workup: After cooling, filter the reaction mixture through a frit to remove the resin. Wash the resin with 2 mL MeCN.
- Isolation: Concentrate the filtrate under reduced pressure. The residue is typically >90% pure 1,2,4-oxadiazole.

## Protocol B: Solution-Phase T3P® Mediated Synthesis

Best for: Scale-up (>1g), cost-sensitive projects, "Green" chemistry compliance. Chemistry: Propylphosphonic anhydride (T3P) coupling.[5]

### Materials

- Carboxylic Acid: 1.0 equiv
- Amidoxime: 1.1 equiv
- Reagent: T3P (50% w/w in EtOAc or DMF), 1.5 equiv.
- Base: Triethylamine (TEA) or DIPEA, 3.0 equiv.

- Solvent: Ethyl Acetate (EtOAc) or DMF.

## Step-by-Step Procedure

- Activation: Dissolve carboxylic acid and base in the solvent in a microwave vial. Add T3P solution dropwise. Stir for 2 minutes at room temperature.
- Addition: Add the amidoxime in one portion.
- Irradiation:
  - Temperature: 140°C
  - Time: 20 minutes
- Workup: Dilute with water and extract with EtOAc. Wash organic layer with NaHCO<sub>3</sub> (sat.) and Brine. Dry over MgSO<sub>4</sub> and concentrate.

## Data & Optimization Guidelines

### Comparison: Microwave vs. Conventional Thermal

The following data highlights the efficiency gains using Protocol A (HBTU/PS-BEMP) compared to standard thermal reflux in Toluene/Pyridine.

Parameter	Conventional Thermal	Microwave-Assisted (Protocol A)
Reaction Temp	110°C (Reflux)	160°C
Reaction Time	18–24 Hours	15 Minutes
Yield (Avg)	45–65%	85–98%
Purity (Crude)	Low (requires column)	High (>90%, often no column)
Solvent	Toluene/Pyridine (Toxic)	Acetonitrile (Class 2)

## Solvent Screening for Microwave Efficiency

Dielectric properties of the solvent significantly impact heating rates.

Solvent	Dielectric Constant ( $\epsilon$ )	Heating Efficiency	Recommendation
Acetonitrile	37.5	High	Preferred. Clean workup.
DMF	36.7	Very High	Use as co-solvent for solubility. Hard to remove.
Ethanol	24.5	High	Good for green chem, but lower temp limit (pressurizes).
Toluene	2.4	Low	Avoid. Poor microwave coupling.

## Troubleshooting & Critical Parameters

- **Incomplete Cyclization:** If LC-MS shows the O-acylamidoxime intermediate (M+18 relative to product), increase temperature to 170°C rather than extending time. The dehydration is endothermic and entropy-driven.
- **Resin Degradation:** For Protocol A, do not exceed 180°C, as the polystyrene backbone of PS-BEMP may degrade.
- **Pressure Limits:** Acetonitrile at 160°C generates significant pressure (~10–12 bar). Ensure your microwave vial is rated for at least 20 bar.
- **Steric Hindrance:** For ortho-substituted carboxylic acids, extend reaction time to 30 minutes and use T3P (Protocol B) as it is a more aggressive dehydrating agent than HBTU.

## References

- Wang, Y., et al. (2005). "Rapid and Efficient Synthesis of 1,2,4-Oxadiazoles Utilizing Polymer-Supported Reagents under Microwave Heating." *Organic Letters*, 7(5), 925–928.
- Adib, M., et al. (2006).[6] "A Novel, One-Pot, Three-Component Synthesis of 1,2,4-Oxadiazoles under Microwave Irradiation and Solvent-Free Conditions." *Synlett*, 2006(11),

1765–1767.

- Augustine, J. K., et al. (2009).<sup>[6]</sup> "PTSA-ZnCl<sub>2</sub> is an efficient and mild catalyst for the synthesis of 3,5-disubstituted-1,2,4-oxadiazoles from amidoximes and organic nitriles."<sup>[6]</sup> Journal of Organic Chemistry, 74, 5640-5643.<sup>[6]</sup>
- Bostancioglu, R. B., et al. (2020). "A review on microwave assisted synthesis, mechanism of action and structure activity relationship of 1, 3, 4-oxadiazole derivatives as anticancer agent." World Journal of Advanced Research and Reviews.
- Nagy, et al. (2025). "One-Pot Synthesis of 1,2,4-Oxadiazoles from Carboxylic Acid Esters and Amidoximes Using Potassium Carbonate." Journal of Heterocyclic Chemistry.

#### Need Custom Synthesis?

BenchChem offers custom synthesis for rare earth carbides and specific isotopic labeling.

Email: [info@benchchem.com](mailto:info@benchchem.com) or [Request Quote Online](#).

## Sources

- [1. ias.ac.in](http://ias.ac.in) [[ias.ac.in](http://ias.ac.in)]
- [2. Multistep Synthesis of 1,2,4-Oxadiazoles via DNA-Conjugated Aryl Nitrile Substrates - PMC](#) [[pmc.ncbi.nlm.nih.gov](http://pmc.ncbi.nlm.nih.gov)]
- [3. mdpi.com](http://mdpi.com) [[mdpi.com](http://mdpi.com)]
- [4. pubs.acs.org](http://pubs.acs.org) [[pubs.acs.org](http://pubs.acs.org)]
- [5. researchgate.net](http://researchgate.net) [[researchgate.net](http://researchgate.net)]
- [6. 1,2,4-Oxadiazole synthesis](#) [[organic-chemistry.org](http://organic-chemistry.org)]
- To cite this document: BenchChem. [Application Note: Precision Microwave-Assisted Synthesis of 1,2,4-Oxadiazole Derivatives]. BenchChem, [2026]. [Online PDF]. Available at: [<https://www.benchchem.com/product/b1506632/docs#application-note-precision-microwave-assisted-synthesis-of-1-2-4-oxadiazole-derivatives>]

#### Disclaimer & Data Validity:

The information provided in this document is for Research Use Only (RUO) and is strictly not intended for diagnostic or therapeutic procedures. While BenchChem strives to provide accurate protocols, we make no warranties, express or implied, regarding the fitness of this product for every specific experimental setup.

**Technical Support:** The protocols provided are for reference purposes. Unsure if this reagent suits your experiment?

**Need Industrial/Bulk Grade?** [Request Custom Synthesis Quote](#)

## BenchChem

Our mission is to be the trusted global source of essential and advanced chemicals, empowering scientists and researchers to drive progress in science and industry.

### Contact

Address: 3281 E Guasti Rd  
Ontario, CA 91761, United States  
Phone: (601) 213-4426  
Email: [info@benchchem.com](mailto:info@benchchem.com)

[Contact our Ph.D. Support Team for a compatibility check](#)