

# An In-Depth Technical Guide to Fmoc Protection of Non-Natural Amino Acids

**Author:** BenchChem Technical Support Team. **Date:** May 2026

## Compound of Interest

**Compound Name:** 4-Fmoc-3-(2-carboxy-ethyl)-morpholine

**CAS No.:** 885274-10-2

**Cat. No.:** B1506980

[Get Quote](#)

## Introduction: The Indispensable Role of Non-Natural Amino Acids and the Dominance of Fmoc Chemistry

The incorporation of non-natural amino acids into peptides has become a cornerstone of modern drug discovery and development. These unique building blocks offer the ability to introduce novel functionalities, enhance proteolytic stability, constrain peptide conformation, and ultimately improve the therapeutic properties of peptide-based drugs.<sup>[1][2]</sup> The successful synthesis of these modified peptides, however, is critically dependent on robust and reliable protecting group strategies. Among these, the 9-fluorenylmethoxycarbonyl (Fmoc) strategy has emerged as the preeminent choice for solid-phase peptide synthesis (SPPS).<sup>[1][2][3][4]</sup>

This guide provides an in-depth technical overview of the Fmoc protection of non-natural amino acids, addressing the underlying chemical principles, practical considerations for various classes of non-natural amino acids, and troubleshooting common challenges. As a self-validating system, the protocols and insights described herein are grounded in established chemical principles and field-proven experience, aimed at empowering researchers, scientists,

and drug development professionals to confidently navigate the intricacies of this critical synthetic step.

## I. The Chemistry of Fmoc Protection and Deprotection: A Tale of Basicity and Aromaticity

The widespread adoption of Fmoc chemistry stems from its mild reaction conditions and orthogonality to common acid-labile side-chain protecting groups.<sup>[1][3][4]</sup> Understanding the mechanisms of both the protection and deprotection steps is fundamental to its successful application.

### The Mechanism of Fmoc Protection

The Fmoc group is introduced to the primary or secondary amine of an amino acid via nucleophilic attack on an activated Fmoc reagent. The most commonly used reagents are 9-fluorenylmethyl chloroformate (Fmoc-Cl) and N-(9-fluorenylmethoxycarbonyloxy)succinimide (Fmoc-OSu). The reaction is typically carried out under basic conditions, which deprotonate the amino group, enhancing its nucleophilicity.

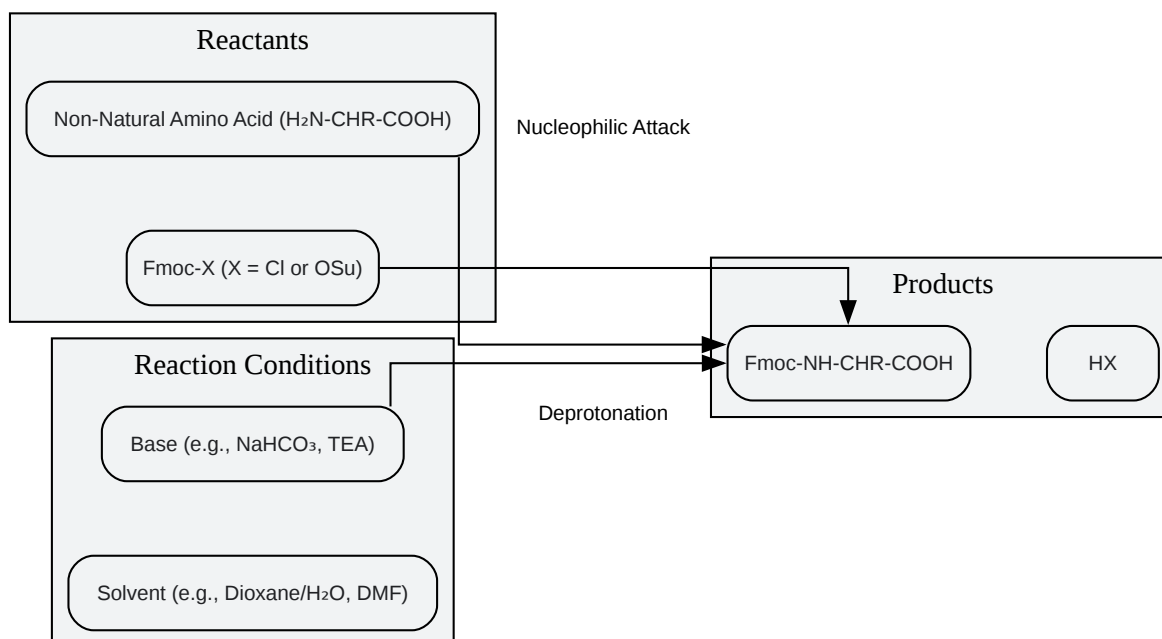

[Click to download full resolution via product page](#)

Caption: General workflow for the Fmoc protection of a non-natural amino acid.

The choice between Fmoc-Cl and Fmoc-OSu is often a matter of balancing reactivity and stability. Fmoc-Cl is more reactive but also more susceptible to hydrolysis. Fmoc-OSu is more stable, reducing the formation of unwanted side products like oligopeptides.[5] However, it's important to be aware that Fmoc-OSu can be a source of Fmoc- $\beta$ -Ala-OH impurity through a Lossen-type rearrangement, which can complicate purification.[5]

## The Mechanism of Fmoc Deprotection

The defining feature of the Fmoc group is its lability to mild bases, most commonly a 20% solution of piperidine in dimethylformamide (DMF).[1][3] The deprotection proceeds via a  $\beta$ -elimination mechanism. The base abstracts the acidic proton on the fluorenyl ring system, leading to the formation of a dibenzofulvene (DBF) intermediate and the release of the free amine. The DBF is then trapped by the amine base to form a stable adduct, which is washed away.

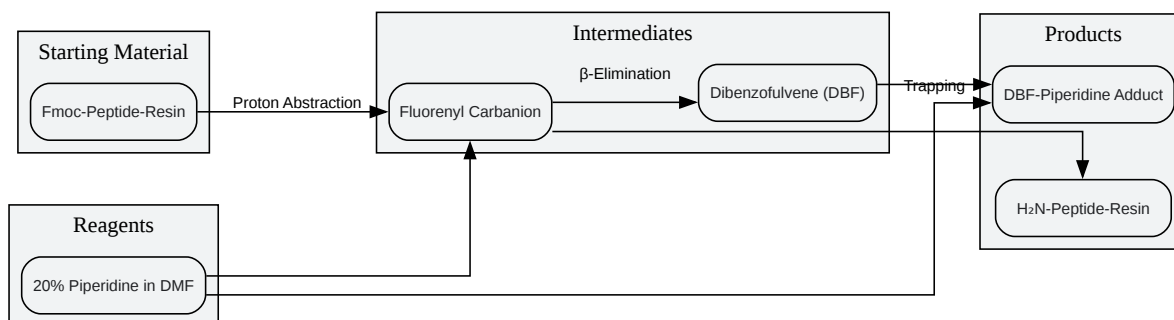

[Click to download full resolution via product page](#)

Caption: Mechanism of Fmoc deprotection using piperidine.

The strong UV absorbance of the DBF-piperidine adduct at around 300 nm allows for real-time monitoring of the deprotection reaction, a key advantage of Fmoc-based SPPS.[1]

## II. Strategies for Fmoc Protection of Diverse Non-Natural Amino Acids

While the fundamental principles of Fmoc protection are universal, the structural diversity of non-natural amino acids necessitates tailored strategies to overcome specific challenges such as steric hindrance, low reactivity, and the need for orthogonal side-chain protection.

### Sterically Hindered Amino Acids (e.g., $\alpha,\alpha$ -disubstituted)

The presence of bulky substituents at the  $\alpha$ -carbon can significantly impede the approach of the Fmoc-donating reagent. Overcoming this steric hindrance often requires more forcing reaction conditions.

- **Increased Reaction Time and Temperature:** Simply extending the reaction time or moderately increasing the temperature can often drive the reaction to completion.

- **Alternative Reagents:** In some cases, more reactive reagents like Fmoc-Cl may be preferable to Fmoc-OSu.
- **Microwave-Assisted Synthesis:** Microwave irradiation can significantly accelerate the reaction by providing localized, efficient heating, often leading to higher yields in shorter times.

For particularly challenging cases, such as the functionalized secondary amine on a quaternary center of some bis-amino acids, the steric hindrance can be so profound that the amine does not react at an appreciable rate, obviating the need for protection during subsequent coupling steps.[\[6\]](#)

## N-Methylated Amino Acids

N-methylated amino acids are crucial for improving the pharmacokinetic properties of peptides. [\[7\]](#) Their synthesis often involves a multi-step process where the N-methylation is performed on a protected amino acid, followed by the introduction of the Fmoc group. A common strategy is the Biron-Kessler method, which involves protection of the  $\alpha$ -amino group with 2-nitrobenzenesulfonyl (o-NBS), methylation, and then removal of the o-NBS group before Fmoc protection. [\[7\]](#) An alternative, more efficient synthesis involves the formation of an intermediate 5-oxazolidinone from the Fmoc-amino acid, which is then reductively opened. [\[8\]](#)

Amino Acid Type	Key Challenge	Recommended Strategy	Reference
$\alpha,\alpha$ -disubstituted	Steric Hindrance	Increased reaction time/temperature, microwave assistance, use of Fmoc-Cl.	[9]
N-methylated	Multi-step synthesis	Biron-Kessler method (o-NBS protection, methylation, deprotection, Fmoc protection) or via 5-oxazolidinone intermediate.	[7][8]
$\beta$ -amino acids	Potential for side reactions	Standard Fmoc protection conditions are generally effective. Careful monitoring for impurities is crucial.	[10]
Proline Analogs	Secondary amine reactivity	Copper chelation strategy to temporarily block other reactive groups before Fmoc protection of the proline nitrogen.	[6]

## Orthogonal Side-Chain Protection

Many non-natural amino acids possess functional groups in their side chains that require protection to prevent unwanted side reactions during peptide synthesis. The choice of protecting group is critical and must be orthogonal to the Fmoc group, meaning it should be stable to the basic conditions of Fmoc deprotection but readily cleavable under different conditions, typically strong acid during the final cleavage from the resin.[3][4]

Functional Group	Common Protecting Group	Cleavage Condition
Carboxylic Acid (Asp, Glu)	tert-Butyl (tBu)	Strong Acid (TFA)
Hydroxyl (Ser, Thr, Tyr)	tert-Butyl (tBu)	Strong Acid (TFA)
Amine (Lys, Orn)	tert-Butoxycarbonyl (Boc)	Strong Acid (TFA)
Guanidinium (Arg)	2,2,4,6,7-Pentamethyldihydrobenzofuran-5-sulfonyl (Pbf)	Strong Acid (TFA)
Thiol (Cys)	Trityl (Trt), Acetamidomethyl (Acm)	Strong Acid (TFA), Iodine
Imidazole (His)	Trityl (Trt)	Strong Acid (TFA)

This orthogonality is a cornerstone of Fmoc-SPPS, allowing for the selective manipulation of different parts of the peptide molecule.<sup>[4][11]</sup>

### III. Experimental Protocols: A Practical Guide

The following protocols provide a starting point for the Fmoc protection of non-natural amino acids. Optimization may be required depending on the specific properties of the amino acid.

#### General Protocol for Fmoc Protection using Fmoc-OSu

This protocol is suitable for most non-natural amino acids without significant steric hindrance.

- **Dissolution:** Dissolve the non-natural amino acid (1.0 equivalent) in a 1:1 mixture of 1,4-dioxane and 10% aqueous sodium carbonate.
- **Addition of Fmoc-OSu:** To the stirring solution, add Fmoc-OSu (1.05 equivalents) portion-wise over 30 minutes.
- **Reaction:** Allow the reaction to stir at room temperature overnight. Monitor the reaction progress by thin-layer chromatography (TLC) or LC-MS.
- **Work-up:** Once the reaction is complete, dilute the mixture with water and wash with diethyl ether to remove unreacted Fmoc-OSu and N-hydroxysuccinimide.

- Acidification: Cool the aqueous layer in an ice bath and acidify to pH 2 with 1 M HCl.
- Extraction: Extract the product with ethyl acetate or dichloromethane.
- Drying and Concentration: Dry the organic layer over anhydrous sodium sulfate, filter, and concentrate under reduced pressure to yield the crude Fmoc-protected amino acid.
- Purification: Purify the crude product by flash chromatography or recrystallization as needed.

## Protocol for Fmoc Protection of a Sterically Hindered Amino Acid

This protocol incorporates modifications to improve the yield for sterically demanding substrates.

- Dissolution: Dissolve the sterically hindered amino acid (1.0 equivalent) in DMF.
- Base Addition: Add N,N-Diisopropylethylamine (DIPEA) (2.0 equivalents).
- Addition of Fmoc-Cl: Slowly add a solution of Fmoc-Cl (1.2 equivalents) in DMF to the stirring mixture.
- Microwave Irradiation (Optional): If the reaction is sluggish at room temperature, heat the reaction mixture in a microwave synthesizer at 50-60°C for 30-60 minutes. Monitor the reaction progress closely.
- Work-up and Purification: Follow steps 4-8 from the general protocol.

## IV. Analysis and Characterization: Ensuring Quality and Purity

Thorough analytical characterization is essential to confirm the successful synthesis and purity of the Fmoc-protected non-natural amino acid.[\[12\]](#)

Analytical Technique	Purpose	Typical Conditions
Reverse-Phase HPLC (RP-HPLC)	Purity assessment and quantification.	Column: C18; Mobile Phase A: 0.1% TFA in Water; Mobile Phase B: 0.1% TFA in Acetonitrile; Gradient: 5-95% B over 20-30 min; Detection: UV at 254 nm and 301 nm.
Mass Spectrometry (MS)	Confirmation of molecular weight and identity.	Electrospray Ionization (ESI) or Matrix-Assisted Laser Desorption/Ionization (MALDI).
Nuclear Magnetic Resonance (NMR)	Structural elucidation and confirmation.	$^1\text{H}$ and $^{13}\text{C}$ NMR in a suitable deuterated solvent (e.g., $\text{CDCl}_3$ , $\text{DMSO-d}_6$ ).
Optical Rotation	Determination of enantiomeric purity.	Measured on a polarimeter at a specific wavelength (e.g., 589 nm). <a href="#">[13]</a>

## V. Troubleshooting Common Challenges

Problem	Potential Cause	Suggested Solution
Low Yield	Incomplete reaction due to steric hindrance or low reactivity.	Increase reaction time/temperature, use microwave assistance, switch to a more reactive Fmoc reagent (Fmoc-Cl).
Poor solubility of the amino acid.	Screen different solvent systems (e.g., DMF, NMP, aqueous mixtures).	
Side Reactions	Formation of di-Fmoc protected amino acid.	Use a slight excess of the amino acid relative to the Fmoc reagent.
Hydrolysis of Fmoc-Cl.	Ensure anhydrous reaction conditions.	
Purification Difficulties	Presence of closely eluting impurities (e.g., Fmoc- $\beta$ -Ala-OH from Fmoc-OSu).	Use high-purity Fmoc-OSu or consider using Fmoc-Cl. Optimize chromatography conditions.
Oily product that is difficult to handle.	Attempt to crystallize the product from a suitable solvent system.	

## VI. Conclusion: A Foundation for Innovation

The Fmoc protection of non-natural amino acids is a critical enabling technology in the field of peptide science. While the core principles are well-established, the ever-increasing structural complexity of non-natural amino acids demands a nuanced and adaptable approach. By understanding the underlying mechanisms, tailoring reaction strategies to the specific substrate, and employing rigorous analytical techniques, researchers can confidently and efficiently synthesize these valuable building blocks. This mastery is not merely a synthetic exercise; it is the foundation upon which the next generation of innovative peptide therapeutics will be built. The high quality and purity of Fmoc-protected amino acids are paramount, as they

directly translate to higher yields, easier purification of the final peptide, and a more consistent impurity profile, ultimately simplifying troubleshooting and accelerating the path to discovery.[3]

## References

- Hioki, K., et al. (2006). New, stable amino-protecting reagents, Boc-DMT and Fmoc-DMT, were prepared, and found to be useful for the introduction of Boc and Fmoc groups into amines. *Synthesis*, 2006, 1931-1933. [[Link](#)]
- Gant, T. G., et al. (2022). Development of Fmoc-Protected Bis-Amino Acids toward Automated Synthesis of Highly Functionalized Spiroligomers. *Organic Letters*, 24(18), 3334–3338. [[Link](#)]
- The Royal Society of Chemistry. (2011). An efficient and expeditious Fmoc protection of amines and amino acids in aqueous media. *Green Chemistry*. [[Link](#)]
- Subirós-Funosas, R., et al. (2009). Large-Scale Syntheses of Fmoc-Protected Non-Proteogenic Amino Acids: Useful Building Blocks for Combinatorial Libraries. *ResearchGate*. [[Link](#)]
- Monty, O. B. C., et al. (2020). Solution-Phase Fmoc-Based Peptide Synthesis for DNA-Encoded Chemical Libraries: Reaction Conditions, Protecting Group Strategies, and Pitfalls. *ACS Combinatorial Science*, 22(12), 833-843. [[Link](#)]
- Fields, G. B. (2011). Advances in Fmoc solid-phase peptide synthesis. *Peptide Science*, 96(4), 365-377. [[Link](#)]
- Lauer, A., et al. (2007). Identification of Fmoc-β-Ala-OH and Fmoc-β-Ala-amino acid-OH as new impurities in Fmoc-protected amino acid derivatives. *ResearchGate*. [[Link](#)]
- García-Ramos, Y., et al. (2023). Protocol for Facile Synthesis of Fmoc-N-Me-AA-OH Using 2-CTC Resin as Temporary and Reusable Protecting Group. *Molecules*, 28(22), 7586. [[Link](#)]
- Zacharie, B., et al. (2007). An Improved Synthesis of Fmoc-N-methyl-α-amino Acids. *The Journal of Organic Chemistry*, 72(16), 6234–6237. [[Link](#)]

- Isidro-Llobet, A., et al. (2009). Amino Acid-Protecting Groups. *Chemical Reviews*, 109(6), 2455–2504. [[Link](#)]
- Jad, Y. E., et al. (2018). Solid phase peptide synthesis using side-chain unprotected arginine and histidine with Oxyma Pure/TBEC in green solvents. *Organic & Biomolecular Chemistry*, 16(37), 8439-8445. [[Link](#)]
- Aurelio, L., et al. (2004). A preparation of N-Fmoc-N-methyl- $\alpha$ -amino acids and N-nosyl-N-methyl- $\alpha$ -amino acids. ResearchGate. [[Link](#)]
- Isidro-Llobet, A., et al. (2009). Amino Acid-Protecting Groups. *Chemical Reviews*, 109(6), 2455–2504. [[Link](#)]
- Albericio, F., et al. (2018). Protecting Groups in Peptide Synthesis. ResearchGate. [[Link](#)]
- Bio-Synthesis Inc. (2024). Fmoc-Based Peptide Synthesis: A Complete Guide to Chemistry, Steps & Advantages. Retrieved from [[Link](#)]
- AAPPTec. (n.d.). Overview of Solid Phase Peptide Synthesis (SPPS). Retrieved from [[Link](#)]
- Denton, J. R., & Tang, Y. (2019). Avoid Protecting Groups. In *Green Chemistry: Principles and Case Studies*. [[Link](#)]
- Miyanaga, A., & Katsuyama, Y. (2026). Protecting Group Strategies in Natural Product Biosynthesis. *Journal of Natural Products*. [[Link](#)]

### Need Custom Synthesis?

BenchChem offers custom synthesis for rare earth carbides and specific isotopic labeling.

Email: [info@benchchem.com](mailto:info@benchchem.com) or [Request Quote Online](#).

## Sources

- 1. [chempep.com](http://chempep.com) [[chempep.com](http://chempep.com)]
- 2. [bocsci.com](http://bocsci.com) [[bocsci.com](http://bocsci.com)]
- 3. [Fmoc Amino Acids for SPPS - AltaBioscience](http://altabioscience.com) [[altabioscience.com](http://altabioscience.com)]

- [4. bocsci.com \[bocsci.com\]](#)
- [5. researchgate.net \[researchgate.net\]](#)
- [6. pubs.acs.org \[pubs.acs.org\]](#)
- [7. Protocol for Facile Synthesis of Fmoc-N-Me-AA-OH Using 2-CTC Resin as Temporary and Reusable Protecting Group - PMC \[pmc.ncbi.nlm.nih.gov\]](#)
- [8. pubs.acs.org \[pubs.acs.org\]](#)
- [9. pubs.acs.org \[pubs.acs.org\]](#)
- [10. researchgate.net \[researchgate.net\]](#)
- [11. peptide.com \[peptide.com\]](#)
- [12. pdf.benchchem.com \[pdf.benchchem.com\]](#)
- [13. rsc.org \[rsc.org\]](#)
- To cite this document: BenchChem. [An In-Depth Technical Guide to Fmoc Protection of Non-Natural Amino Acids]. BenchChem, [2026]. [Online PDF]. Available at: [\[https://www.benchchem.com/product/b1506980/docs#an-in-depth-technical-guide-to-fmoc-protection-of-non-natural-amino-acids\]](https://www.benchchem.com/product/b1506980/docs#an-in-depth-technical-guide-to-fmoc-protection-of-non-natural-amino-acids)

---

#### Disclaimer & Data Validity:

The information provided in this document is for Research Use Only (RUO) and is strictly not intended for diagnostic or therapeutic procedures. While BenchChem strives to provide accurate protocols, we make no warranties, express or implied, regarding the fitness of this product for every specific experimental setup.

**Technical Support:** The protocols provided are for reference purposes. Unsure if this reagent suits your experiment?

**Need Industrial/Bulk Grade?** [Request Custom Synthesis Quote](#)

# BenchChem

Our mission is to be the trusted global source of essential and advanced chemicals, empowering scientists and researchers to drive progress in science and industry.

## Contact

Address: 3281 E Guasti Rd

Ontario, CA 91761, United States

Phone: (601) 213-4426

Email: [info@benchchem.com](mailto:info@benchchem.com)

[Contact our Ph.D. Support Team for a compatibility check](#)