

Technical Support Center: 4-Chloro-2-isopropylquinazoline Synthesis

Author: BenchChem Technical Support Team. **Date:** May 2026

Compound of Interest

Compound Name: 4-Chloro-2-isopropylquinazoline

CAS No.: 38154-42-6

Cat. No.: B1504095

[Get Quote](#)

Case ID: #QZN-ISO-CL4 Subject: Impurity Profile & Process Optimization for **4-Chloro-2-isopropylquinazoline** Assigned Specialist: Senior Application Scientist, Process Chemistry Division

Executive Summary & Chemical Context[1][2][3][4][5][6][7]

The synthesis of **4-chloro-2-isopropylquinazoline** is a critical gateway step in the production of kinase inhibitors. While the transformation appears to be a standard chlorodehydroxylation, the 2-isopropyl group introduces specific steric and electronic nuances that distinguish it from the simpler 2-methyl or 2-phenyl analogs.

Users frequently encounter two competing failure modes:

- Reversion to Starting Material (Hydrolysis): The C4-Cl bond is an imidoyl chloride equivalent and is highly labile to moisture, particularly under acidic conditions.

- Dimerization: Steric hindrance at the C2 position can slow the final chlorination step, allowing the activated intermediate to react with unreacted starting material, forming a "pseudodimer" (O-linked or N-linked).

This guide provides a mechanistic breakdown and actionable troubleshooting steps to isolate high-purity material.

Reaction Mechanism & Critical Control Points

To troubleshoot effectively, one must understand the activation pathway. We utilize Phosphorus Oxychloride (POCl_3), often with a tertiary amine base (DIEA or Et_3N).

The Pathway

The reaction proceeds via an O-phosphorylated intermediate.[1] The critical insight is that dimer formation is temperature-dependent.

- Low Temp ($<25^\circ\text{C}$): Phosphorylation occurs.[1][2][3] If the system is basic, dimer formation is suppressed.[1][2][3]
- High Temp ($>70^\circ\text{C}$): Chloride displacement occurs (Product formation).

Mechanistic Visualization (Graphviz)

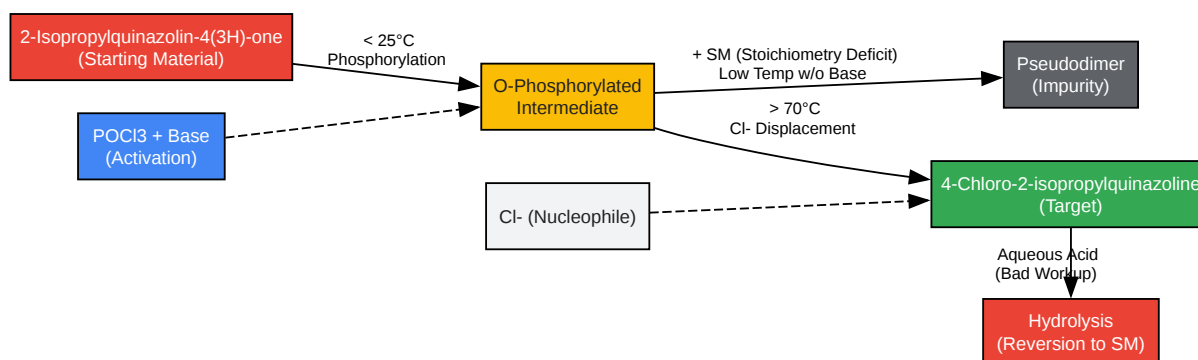

[Click to download full resolution via product page](#)

Figure 1: Reaction pathway showing the critical bifurcation between product formation, dimerization, and hydrolysis.^{[2][4]}

Troubleshooting Guide (FAQ Format)

Issue 1: "I see a large peak at [2M-HCl] or [2M-35] in my LCMS."

Diagnosis:Pseudodimer Formation. This occurs when the activated phosphorylated intermediate reacts with a molecule of unreacted starting material instead of a chloride ion. This is common when the reaction is heated too quickly or if POCl₃ is the limiting reagent.

Corrective Action:

- Staged Heating: Do not reflux immediately. Stir at 0°C–RT for 30 minutes to ensure complete phosphorylation of the SM before heating to drive the chloride displacement.
- Base Catalysis: Ensure you are using a base (DIEA is preferred over Et₃N for solubility). The base suppresses dimer formation by stabilizing the intermediate.
- Reagent Stoichiometry: Increase POCl₃ to 3–5 equivalents. The 2-isopropyl group adds steric bulk, making the C4 position less accessible; excess reagent drives the equilibrium.

Issue 2: "My conversion was 98% by HPLC, but isolated yield is 40% and SM is back."

Diagnosis:Hydrolysis during Workup. The **4-chloro-2-isopropylquinazoline** is an imidoyl chloride. In the presence of water and acid (generated from quenching POCl₃), it rapidly hydrolyzes back to the quinazolinone.

Corrective Action:

- The "Mini-Workup" Test: Never trust an LCMS taken directly from the reaction mixture. Always quench a 50 μL aliquot into MeOH/NH₃ before analyzing. This tells you if the SM is real or an artifact of the analysis.
- Quench Protocol:

- Avoid: Pouring reaction mixture into water (generates hot HCl).
- Preferred: Pour reaction mixture slowly into ice-cold sat. NaHCO_3 or 2M NaOH/ice. Maintain pH > 8.
- Alternative: Remove excess POCl_3 via rotary evaporation (with a toluene azeotrope) before aqueous contact.

Issue 3: "The reaction is sluggish; 20% SM remains after 12 hours."

Diagnosis: Steric Hindrance / Deactivated Electrophile. The isopropyl group at C2 donates electron density and provides steric bulk, making the C4-O-P bond harder to break by the incoming chloride nucleophile.

Corrective Action:

- Catalytic DMF: Add 2–3 drops of DMF. This forms the Vilsmeier-Haack reagent (chloroiminium species), which is a far more potent electrophile than POCl_3 alone.
- Temperature: Ensure internal temperature reaches $>85^\circ\text{C}$.

Optimized Experimental Protocol

Objective: Synthesis of 5.0 g of **4-Chloro-2-isopropylquinazoline**.

Parameter	Specification	Notes
Reagent	POCl_3 (Phosphorus Oxychloride)	5.0 equiv. Freshly distilled if yellow.
Base	N,N-Diisopropylethylamine (DIEA)	1.2 equiv. Scavenges HCl.
Catalyst	DMF (Dimethylformamide)	0.1 equiv (Catalytic).
Solvent	Toluene or Neat (in POCl_3)	Toluene preferred for temp control.

Step-by-Step Procedure:

- Setup: Flame-dry a 100 mL Round Bottom Flask (RBF) equipped with a magnetic stir bar and a reflux condenser under N₂ atmosphere.
- Charging: Add 2-isopropylquinazolin-4(3H)-one (1.0 equiv) and Toluene (5 vol).
- Activation (Low Temp): Cool to 0°C. Add DIEA (1.2 equiv) followed by dropwise addition of POCl₃ (5.0 equiv). Do not let temp rise above 10°C.
- Catalysis: Add DMF (3 drops). Stir at 0°C for 30 mins, then warm to RT for 30 mins.
 - Checkpoint: This ensures complete phosphorylation and suppresses dimerization.
- Reaction (High Temp): Heat to 90°C for 3–5 hours.
- Monitoring: Quench a 20 μL aliquot into 500 μL dry MeOH (forms the 4-methoxy derivative) or cold NH₃/MeOH. Analyze by HPLC. Do not analyze the crude acid mixture directly.
- Workup (Critical):
 - Concentrate the reaction mixture under reduced pressure to remove bulk POCl₃ (use a base trap!).
 - Redissolve residue in DCM.
 - Pour slowly into a rapidly stirring mixture of Ice/Sat. NaHCO₃.^[5]
 - Safety: Massive gas evolution (CO₂).
- Isolation: Separate organic layer immediately. Wash with cold brine. Dry over MgSO₄. Concentrate to yield the yellow/orange solid. Store under N₂ at -20°C.

Comparative Reagent Data

Reagent System	Relative Rate	Side Product Risk	Recommended For
POCl ₃ / DIEA	High	Low (if temp controlled)	Standard Synthesis
SOCl ₂ / DMF	Medium	High (Radical chlorination of isopropyl)	Not Recommended
Oxalyl Chloride	Very High	Medium (Over-reaction)	Small scale / unstable substrates

References

- Mechanistic Insight on Quinazolines
 - El-Azab, A. S., et al. "Phosphorus Oxychloride (POCl₃) Chlorination of 4-Quinazolones.
 - Key Finding: Identifies the temperature-dependent suppression of pseudodimers using basic conditions.
- Process Chemistry & Scale-Up
 - Yamagami, T., et al. "Scalable Process Design for a PDE10A Inhibitor." [1] Organic Process Research & Development, 2019.
 - Key Finding: Discusses avoiding hygroscopic intermedi
- Stability of 4-Chloroquinazolines
 - Garcia, R., et al. "Synthesis of 4-chloroquinazolines... and stability studies." Journal of Biological Inorganic Chemistry, 2008. [6]
 - Key Finding: Detailed kinetics on the hydrolysis of the C-Cl bond in physiological and aqueous media.

Need Custom Synthesis?

BenchChem offers custom synthesis for rare earth carbides and specific isotopic labeling.

Email: info@benchchem.com or [Request Quote Online](#).

Sources

- [1. semanticscholar.org \[semanticscholar.org\]](https://www.semanticscholar.org)
- [2. researchgate.net \[researchgate.net\]](https://www.researchgate.net)
- [3. POCl3 chlorination of 4-quinazolones - PubMed \[pubmed.ncbi.nlm.nih.gov\]](https://pubmed.ncbi.nlm.nih.gov)
- [4. Procedure for Disinfection of Drinking Water in Ontario | ontario.ca \[ontario.ca\]](https://www.ontario.ca)
- [5. researchgate.net \[researchgate.net\]](https://www.researchgate.net)
- [6. researchgate.net \[researchgate.net\]](https://www.researchgate.net)
- To cite this document: BenchChem. [Technical Support Center: 4-Chloro-2-isopropylquinazoline Synthesis]. BenchChem, [2026]. [Online PDF]. Available at: [\[https://www.benchchem.com/product/b1504095/docs#technical-support-center-4-chloro-2-isopropylquinazoline-synthesis\]](https://www.benchchem.com/product/b1504095/docs#technical-support-center-4-chloro-2-isopropylquinazoline-synthesis)

Disclaimer & Data Validity:

The information provided in this document is for Research Use Only (RUO) and is strictly not intended for diagnostic or therapeutic procedures. While BenchChem strives to provide accurate protocols, we make no warranties, express or implied, regarding the fitness of this product for every specific experimental setup.

Technical Support: The protocols provided are for reference purposes. Unsure if this reagent suits your experiment?

Need Industrial/Bulk Grade? [Request Custom Synthesis Quote](#)

BenchChem

Our mission is to be the trusted global source of essential and advanced chemicals, empowering scientists and researchers to drive progress in science and industry.

Contact

Address: 3281 E Guasti Rd
Ontario, CA 91761, United States
Phone: (601) 213-4426
Email: info@benchchem.com

Contact our Ph.D. Support Team for a compatibility check