

# Application Note: Microwave-Assisted Synthesis of Quinazoline Scaffolds

**Author:** BenchChem Technical Support Team. **Date:** May 2026

## Compound of Interest

Compound Name: 2,4-Dichloro-7-(trifluoromethoxy)quinazoline

CAS No.: 1160994-83-1

Cat. No.: B1504247

[Get Quote](#)

Focus: Process Intensification, Green Chemistry, and High-Throughput Optimization

## Abstract

The quinazoline pharmacophore is a cornerstone in medicinal chemistry, serving as the core structure for numerous EGFR inhibitors, anticonvulsants, and antimicrobial agents. Conventional thermal synthesis of these bicyclic heterocycles often suffers from prolonged reaction times (12–24 hours), harsh solvents, and tedious workups. This guide details the transition to Microwave-Assisted Organic Synthesis (MAOS), demonstrating how dielectric heating mechanisms can reduce reaction times to minutes while improving yield and purity. We present three validated protocols ranging from solvent-free condensation to metal-catalyzed oxidative cyclization.

## Mechanistic Insight: The Microwave Advantage

Understanding why microwave irradiation accelerates quinazoline synthesis is critical for protocol design. It is not merely "faster heating"; it is a fundamental change in energy transfer.

## Dielectric Heating & The "Specific Microwave Effect"

In conventional heating, energy transfers via convection and conduction from the vessel walls, creating temperature gradients. In MAOS, energy is delivered directly to the molecules via two primary mechanisms:

- **Dipolar Polarization:** Polar molecules (e.g., DMF, water, or polar transition states) align with the oscillating electric field. As the field alternates (2.45 billion times/second), molecular rotation generates internal friction and heat.
- **Ionic Conduction:** Dissolved ions (catalysts like or ionic liquids) oscillate under the field, generating heat through collision.

**Impact on Quinazoline Chemistry:** Many quinazoline syntheses involve a polar transition state (e.g., nucleophilic attack of an amine on a carbonyl). Microwave irradiation selectively stabilizes these polar transition states, effectively lowering the activation energy (

) relative to the ground state—a phenomenon often debated but empirically observed as altered selectivity and rapid kinetics.

## Visualization: Thermal vs. Dielectric Heating

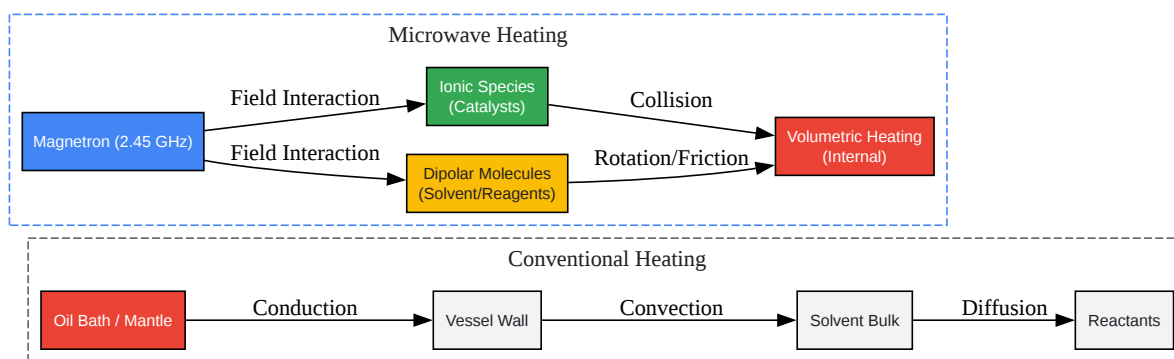

[Click to download full resolution via product page](#)

Caption: Comparison of energy transfer pathways. Conventional heating relies on slow wall-to-center gradients, while microwaves induce direct volumetric heating.

## Validated Experimental Protocols

### Protocol A: Solvent-Free Niementowski Synthesis (Green Chemistry)

Application: Rapid synthesis of 4(3H)-quinazolinones.[1] Rationale: Eliminating solvents maximizes the absorption of microwave energy by the reactants themselves (high loss tangent) and simplifies workup to a "pour-and-filter" process.

Reagents:

- Anthranilic acid (1.0 equiv)
- Formamide (1.5 equiv)
- Solid Support: Montmorillonite K-10 or Acidic Alumina (200% w/w relative to reactants)

Workflow:

- Adsorption: Dissolve anthranilic acid and formamide in a minimal amount of volatile solvent (e.g., MeOH). Add the solid support (K-10). Evaporate the solvent under reduced pressure to leave a free-flowing powder.
- Irradiation: Place the powder in a dedicated microwave process vial. Cap with a pressure-rated septum.
- Parameters:
  - Mode: Open vessel (atmospheric) or Closed (if using a reactor with pressure control).  
Note: Closed vessels are preferred for reproducibility.
  - Temp: 140°C
  - Time: 4–7 minutes

- Power: Dynamic (set max to 300W; instrument modulates to maintain temp).
- Workup: Cool to room temperature. Add hot ethanol to the reaction vessel and vortex to desorb the product. Filter to remove the solid support.
- Crystallization: Concentrate the filtrate. The product usually crystallizes upon cooling.

Data Comparison:

Parameter	Conventional Reflux	Microwave Protocol
Time	18–24 Hours	4–7 Minutes
Yield	65–75%	85–94%

| Solvent Waste | High | Near Zero |

## Protocol B: Aqueous One-Pot Synthesis of 2,3-Dihydroquinazolines

Application: Library generation of 2-substituted quinazolines. Rationale: Water is an excellent microwave solvent (high dielectric constant

at room temp). Under closed-vessel conditions, water can be superheated above 100°C, acting as a pseudo-organic solvent.

Reagents:

- 2-Aminobenzylamine (1.0 mmol)
- Substituted Benzaldehyde (1.0 mmol)
- Solvent: Deionized Water (2 mL)
- Catalyst: None required (autocatalytic or water-promoted).

Workflow:

- Preparation: In a 10 mL microwave vial, combine the amine and aldehyde in water.

- Irradiation:
  - Temp: 120°C
  - Time: 2–5 minutes
  - Stirring: High (magnetic stir bar is essential for heterogeneity).
- Isolation: The product is typically insoluble in water.[1] Upon cooling, the solid precipitates out.
- Purification: Simple filtration and washing with cold water/ethanol mix (9:1).

## Protocol C: Cu-Catalyzed Oxidative Cyclization

Application: Synthesis of 2-arylquinazolin-4(3H)-ones from 2-aminobenzamides and benzyl alcohols. Rationale: This oxidative coupling avoids the use of unstable aldehydes. The copper catalyst couples efficiently with microwave heating due to ionic conduction.

Reagents:

- 2-Aminobenzamide (0.5 mmol)[2]
- Benzyl alcohol derivative (5.0 equiv)[2]
- Catalyst: CuI (20 mol%)[2]
- Base:  
(1.5 equiv)[2]
- Atmosphere:  
balloon (or air in a sealed vessel if headspace is sufficient).

Workflow:

- Setup: Combine reagents in a microwave vial.

- Irradiation:
  - Temp: 130°C
  - Time: 20–30 minutes
  - Power: Dynamic mode.
- Workup: Dilute with EtOAc, wash with brine. Purify via column chromatography (silica gel).

## Optimization & Troubleshooting Guide

### Solvent Selection Matrix

The choice of solvent dictates the heating ramp rate.

- High Absorbers (Fast Heating): DMSO, EtOH, MeOH, Water. Use for reactions with high activation barriers.
- Medium Absorbers: DMF, Acetonitrile. Good general-purpose solvents.
- Low Absorbers (Transparent): Hexane, Toluene, Dioxane. Critical Note: If using these, you must add a "passive heating element" (e.g., SiC vessel walls or a stir bar made of Weflon™) or rely on the polarity of the reactants themselves.

### Common Failure Modes

- Vessel Over-Pressurization: Quinazoline synthesis often releases small molecules ( , ). In a closed vessel, this spikes pressure.
  - Fix: Use a "Power-Max" setting where cooling air is applied during heating to keep the magnetron on without overshooting temperature, or simply reduce sample size.
- Thermal Runaway: Ionic liquids or solid supports can heat exponentially.
  - Fix: Use fiber-optic temperature probes (internal) rather than IR sensors (external) for accurate control.

## General Workflow Diagram

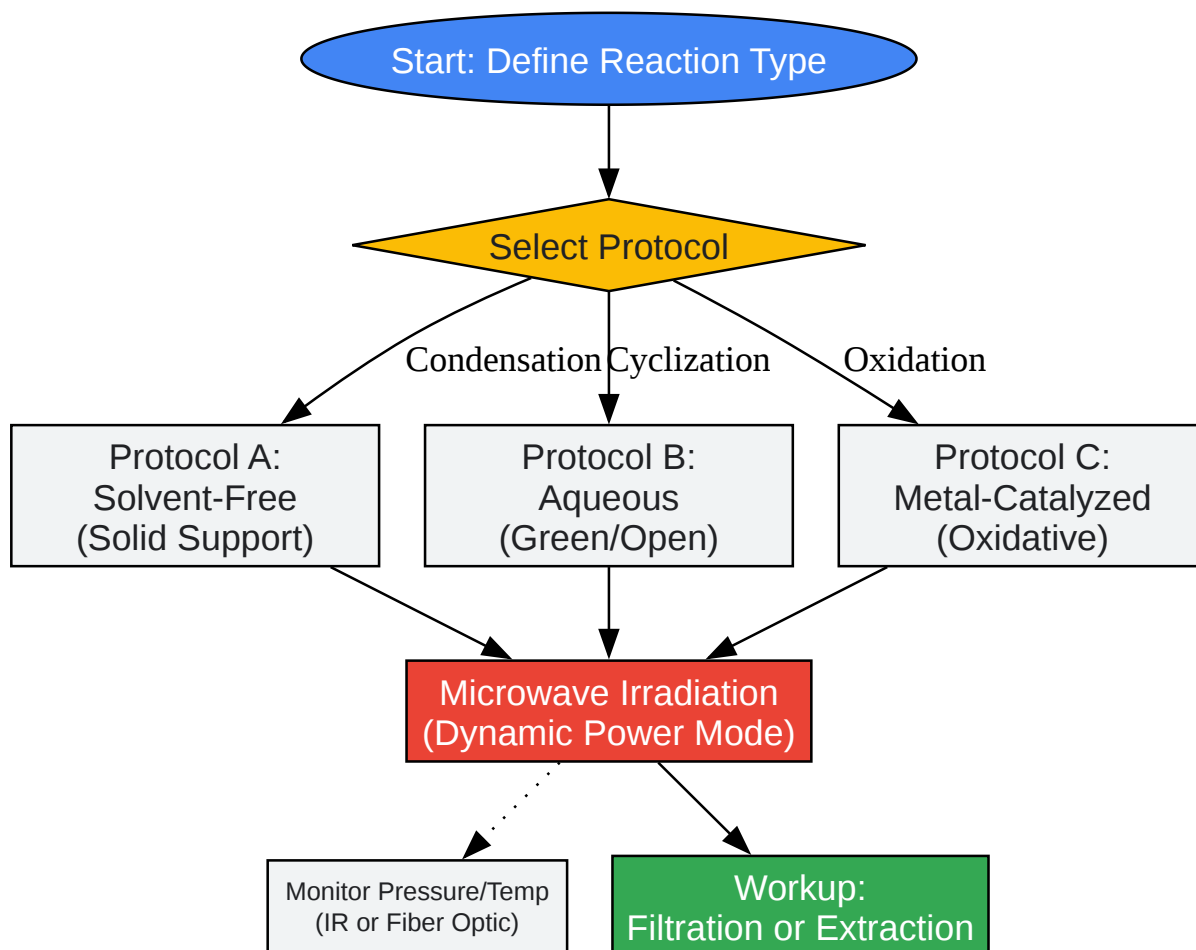

[Click to download full resolution via product page](#)

Caption: Decision tree for selecting the appropriate microwave protocol based on reaction type.

## Safety Considerations

- **Superheating:** Water in a sealed microwave vial can reach 180°C+ without boiling. Opening the vessel before cooling to <60°C can cause an explosive flash boil. Always cool to 50°C before uncapping.
- **Metal Arcing:** When using CuI or other metal catalysts, ensure they are fully dissolved or dispersed. Large metal clumps can cause arcing and vessel failure.

## References

- Microwave-Assisted Synthesis of Quinazolines and Quinazolinones: An Overview. *Frontiers in Chemistry*. (2020). [\[Link\]](#)
- Microwave-assisted commercial copper-catalyzed aerobic oxidative synthesis of AChE quinazolinone inhibitors. *PMC*. (2014). [\[Link\]](#)
- Microwave Assisted Solvent Free Synthesis of Bioactive Quinazolin-4-(3H)-one Compounds. *Journal of Chemical and Pharmaceutical Research*. (2010). [\[Link\]](#)
- Recent Advances in the Transition-Metal-Free Synthesis of Quinazolines. *Molecules*. (2020). [\[Link\]](#)
- Convergent microwave assisted synthesis of quinazolinone using bio-sourced solvent pinane. *RSC Advances*. (2023). [\[Link\]](#)

### *Need Custom Synthesis?*

*BenchChem offers custom synthesis for rare earth carbides and specific isotopic labeling.*

*Email: [info@benchchem.com](mailto:info@benchchem.com) or [Request Quote Online](#).*

## Sources

- [1. researchgate.net \[researchgate.net\]](https://www.researchgate.net)
- [2. Microwave-assisted commercial copper-catalyzed aerobic oxidative synthesis of AChE quinazolinone inhibitors under solvent free conditions - PMC \[pmc.ncbi.nlm.nih.gov\]](https://pubmed.ncbi.nlm.nih.gov/26111111/)
- To cite this document: BenchChem. [Application Note: Microwave-Assisted Synthesis of Quinazoline Scaffolds]. BenchChem, [2026]. [Online PDF]. Available at: [\[https://www.benchchem.com/product/b1504247/docs#application-note-microwave-assisted-synthesis-of-quinazoline-scaffolds\]](https://www.benchchem.com/product/b1504247/docs#application-note-microwave-assisted-synthesis-of-quinazoline-scaffolds)

### **Disclaimer & Data Validity:**

The information provided in this document is for Research Use Only (RUO) and is strictly not intended for diagnostic or therapeutic procedures. While BenchChem strives to provide

accurate protocols, we make no warranties, express or implied, regarding the fitness of this product for every specific experimental setup.

**Technical Support:** The protocols provided are for reference purposes. Unsure if this reagent suits your experiment?

**Need Industrial/Bulk Grade?** [Request Custom Synthesis Quote](#)

## BenchChem

Our mission is to be the trusted global source of essential and advanced chemicals, empowering scientists and researchers to drive progress in science and industry.

### Contact

Address: 3281 E Guasti Rd

Ontario, CA 91761, United States

Phone: (601) 213-4426

Email: [info@benchchem.com](mailto:info@benchchem.com)

[Contact our Ph.D. Support Team for a compatibility check](#)