

Application Note: Comprehensive NMR-Based Structural Characterization of N-isopropylazetidine-2-carboxylic acid

Author: BenchChem Technical Support Team. **Date:** May 2026

Compound of Interest

Compound Name:	(S)-1-Isopropylazetidine-2-carboxylic acid
CAS No.:	255882-98-5
Cat. No.:	B1504832

[Get Quote](#)

Audience: Researchers, scientists, and drug development professionals.

Introduction and Scientific Context

N-isopropylazetidine-2-carboxylic acid is a non-canonical, cyclic amino acid that serves as a valuable building block in medicinal chemistry. Its constrained four-membered ring structure imparts unique conformational rigidity, making it a compelling scaffold for designing novel therapeutics with improved potency and metabolic stability. The precise and unambiguous confirmation of its molecular structure, including stereochemistry, is a critical prerequisite for its application in drug discovery and development.

Nuclear Magnetic Resonance (NMR) spectroscopy is the most powerful analytical technique for the complete structural elucidation of such organic molecules in solution.[1] This application note provides a comprehensive guide, detailing field-proven protocols and in-depth data interpretation for the complete ^1H , ^{13}C , and 2D NMR characterization of N-isopropylazetidine-2-

carboxylic acid. The methodologies described herein are designed to ensure scientific rigor and generate a self-validating dataset for unequivocal structure confirmation.

Predicted Spectral Analysis: Understanding the Molecule's Signature

A thorough analysis begins with a theoretical prediction of the NMR spectrum based on the molecule's structure. This anticipatory step is crucial for designing the correct experiments and for the logical assignment of observed signals.

- ¹H NMR Spectrum: The proton spectrum is expected to show distinct signals for each unique proton environment.
 - Azetidine Ring (C2-H, C3-H₂, C4-H₂): These protons form a complex, coupled spin system. The C2 proton (α-proton) is expected to be a multiplet, shifted downfield due to the adjacent nitrogen and carboxyl group. The C3 and C4 methylene protons will be diastereotopic, appearing as complex multiplets due to both geminal and vicinal coupling. [\[2\]](#)[\[3\]](#)
 - N-isopropyl Group (-CH(CH₃)₂): This group will give rise to two signals: a septet for the methine proton (-CH) due to coupling with the six equivalent methyl protons, and a doublet for the two equivalent methyl groups (-CH₃) due to coupling with the single methine proton.
 - Carboxylic Acid (-COOH): This proton is exchangeable and will typically appear as a broad singlet at a very downfield chemical shift (often >10 ppm).[\[4\]](#)[\[5\]](#) Its visibility and sharpness are highly dependent on the solvent, concentration, and presence of water.[\[4\]](#)
- ¹³C NMR Spectrum: The carbon spectrum provides a count of the unique carbon atoms.
 - Carbonyl Carbon (-COOH): This will be the most downfield signal, typically in the 165-185 ppm range.[\[2\]](#)[\[4\]](#)
 - Azetidine Ring Carbons (C2, C3, C4): These saturated carbons will appear in the aliphatic region. C2 will be the most downfield of the three due to its attachment to both nitrogen and the carboxyl group.

- N-isopropyl Group Carbons (-CH, -CH₃): Two signals are expected, one for the methine carbon and one for the two equivalent methyl carbons.

Experimental Design and Protocols

The following protocols are designed for a standard 400 or 500 MHz NMR spectrometer and represent a robust workflow for complete structural elucidation.

Protocol 1: Sample Preparation

The zwitterionic nature of N-isopropylazetidone-2-carboxylic acid makes solvent selection critical. The choice of solvent affects not only solubility but also the chemical shifts and exchange rates of labile protons (e.g., -COOH).[\[6\]](#)[\[7\]](#)[\[8\]](#)

- Solvent Selection:
 - Methanol-d₄ (CD₃OD): Excellent for solubility. The acidic proton will exchange with the solvent's deuterium, causing the -COOH signal to disappear. This can be used as a confirmatory experiment.
 - DMSO-d₆: A preferred choice as it slows down the exchange of the carboxylic acid proton, allowing it to be observed more clearly as a broad peak.[\[9\]](#)
 - Deuterium Oxide (D₂O): Suitable if pH control is desired. The compound will likely exist in its zwitterionic form. The -COOH proton will exchange and not be visible.
- Procedure:
 1. Accurately weigh 10-15 mg of N-isopropylazetidone-2-carboxylic acid.
 2. Dissolve the sample in 0.6-0.7 mL of the chosen deuterated solvent (e.g., DMSO-d₆) in a clean vial.[\[10\]](#)
 3. To ensure a homogeneous magnetic field and sharp peaks, filter the solution through a pipette plugged with glass wool or a syringe filter directly into a high-quality 5 mm NMR tube.[\[2\]](#)[\[10\]](#) This removes any suspended particulate matter.[\[10\]](#)
 4. Cap the NMR tube securely. Label the tube clearly.[\[11\]](#)

Protocol 2: NMR Data Acquisition

A suite of 1D and 2D NMR experiments is required for a comprehensive analysis.^{[1][12]} The following table outlines the recommended experiments and key acquisition parameters.

Experiment	Purpose	Key Parameters (Typical)
¹ H (Proton)	Observe all proton signals, their chemical shifts, integrations, and multiplicities.	ns=16, d1=2s, Spectral Width=16 ppm
¹³ C (Carbon)	Observe all unique carbon signals.	ns=1024, d1=2s, Spectral Width=240 ppm
DEPT-135	Differentiate CH/CH ₃ (positive) from CH ₂ (negative) signals. Quaternary carbons are absent.	ns=256, d1=2s
¹ H- ¹ H COSY	Identify proton-proton (J-coupling) correlations within 2-3 bonds. ^{[13][14]}	ns=2, d1=1.5s, 256 increments in F1
¹ H- ¹³ C HSQC	Correlate each proton directly to the carbon it is attached to (1-bond correlation). ^{[13][15]}	ns=4, d1=1.5s, 256 increments in F1
¹ H- ¹³ C HMBC	Identify long-range (2-3 bond) correlations between protons and carbons. ^{[13][15]}	ns=8, d1=2s, 256 increments in F1

Data Interpretation and Structural Elucidation Workflow

A systematic, step-by-step approach to spectral interpretation ensures all data are used to build a coherent and validated structure.^[16]

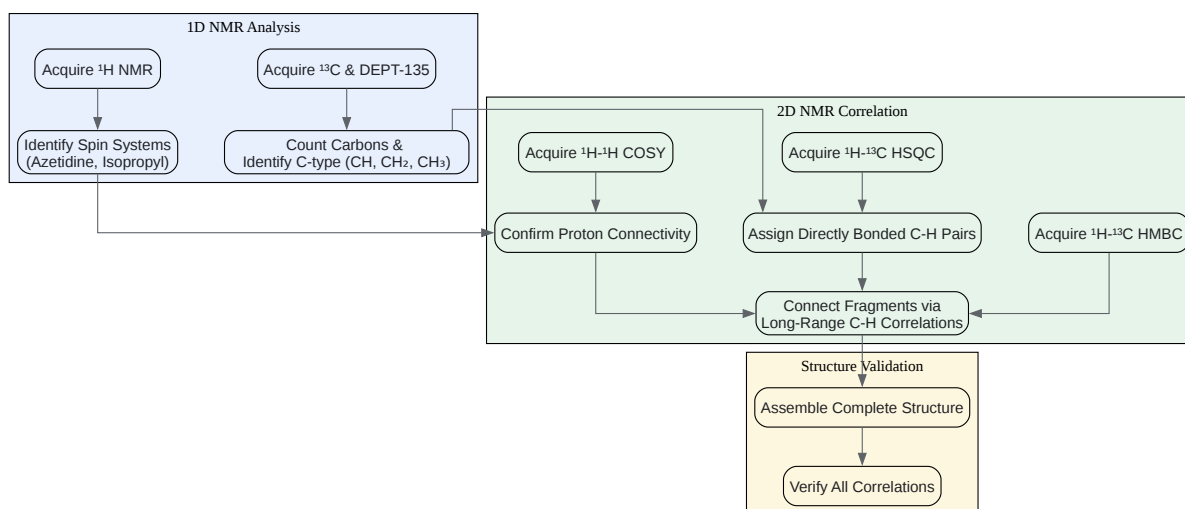

[Click to download full resolution via product page](#)

Caption: Workflow for NMR-based structure elucidation.

Step-by-Step Interpretation:

- ^1H NMR Analysis:
 - Integrate all peaks to determine the relative number of protons.

- Identify the characteristic isopropyl pattern: a 1H septet and a 6H doublet.
- Locate the complex multiplets of the azetidine ring.
- Identify the broad singlet for the COOH proton (if in DMSO-d₆).
- ¹³C and DEPT-135 Analysis:
 - Confirm the total number of expected carbon signals.
 - Use the DEPT-135 spectrum to label each aliphatic carbon as CH/CH₃ (positive phase) or CH₂ (negative phase). The carbonyl carbon will be absent.
- HSQC Analysis:
 - Use the HSQC spectrum to definitively link each proton signal to its directly attached carbon. For example, the 1H septet of the isopropyl group will show a cross-peak to the isopropyl methine carbon signal. This is the most reliable way to assign carbons with attached protons.[\[13\]](#)[\[16\]](#)
- COSY Analysis:
 - Trace the connectivity within the azetidine ring. The C2-H should show a correlation to the C3-H₂ protons. The C3-H₂ protons will correlate with both C2-H and C4-H₂.
 - Confirm the coupling between the isopropyl methine proton and the methyl protons.
- HMBC Analysis (The Key to the Puzzle):
 - The HMBC spectrum connects the isolated spin systems.[\[13\]](#)[\[16\]](#) It is the ultimate tool for confirming the overall molecular framework. Key expected correlations are illustrated below.

Caption: Expected key 2- and 3-bond HMBC correlations.

- A correlation between the isopropyl methine proton and the azetidine C2 and C4 carbons is definitive proof of the N-alkylation site.

- A correlation from the azetidine C2-H to the carbonyl carbon confirms the position of the carboxylic acid group.

Data Summary

The following table provides representative, expected chemical shifts for N-isopropylazetidine-2-carboxylic acid in DMSO-d₆. Actual values may vary slightly based on concentration, temperature, and pH.

Atom Assignment	¹ H Chemical Shift (ppm)	¹³ C Chemical Shift (ppm)	Key HMBC Correlations (from ¹ H)
COOH	~12.5 (broad s)	~172	C2
Azetidine C2-H	~4.0 (m)	~65	COOH, C3, C4
Azetidine C3-H ₂	~2.2-2.5 (m)	~25	C2, C4
Azetidine C4-H ₂	~3.6-3.8 (m)	~55	C2, C3, Isopropyl CH
Isopropyl CH	~3.1 (sept)	~58	Isopropyl CH ₃ , Azetidine C2, C4
Isopropyl CH ₃	~1.2 (d)	~20	Isopropyl CH

Conclusion

The combination of 1D (¹H, ¹³C, DEPT) and 2D (COSY, HSQC, HMBC) NMR spectroscopy provides an unassailable method for the complete and unambiguous structural characterization of N-isopropylazetidine-2-carboxylic acid. The workflow presented here, from logical sample preparation to systematic spectral interpretation, constitutes a self-validating protocol. The HMBC experiment, in particular, is indispensable for connecting the distinct structural fragments and confirming the overall molecular architecture. Adherence to these guidelines will ensure the generation of high-quality, reliable data essential for advancing drug discovery and development programs.

References

- Revisiting the influence of pH on $^{13}\text{C}\alpha\text{H}$ and chemical shifts of glycine and alanine short oligopeptides. (2023). Royal Society Publishing. Available at: [\[Link\]](#)
- Advanced NMR techniques for structural characterisation of heterocyclic structures. (n.d.). ESA-IPB. Available at: [\[Link\]](#)
- STANDARD OPERATING PROCEDURE FOR NMR EXPERIMENTS. (2023). University of Houston. Available at: [\[Link\]](#)
- pH-dependent random coil H, C, and N chemical shifts of the ionizable amino acids. (n.d.). Biological Magnetic Resonance Bank. Available at: [\[Link\]](#)
- Synthesis of New Azetidine and Oxetane Amino Acid Derivatives through Aza-Michael Addition of NH-Heterocycles with Methyl 2-(Azetidin. (2023). PubMed Central. Available at: [\[Link\]](#)
- ^1H -NMR data for the prepared 2-Azetidinone compounds (4a-j). (n.d.). ResearchGate. Available at: [\[Link\]](#)
- Step-by-step procedure for NMR data acquisition. (n.d.). University of Maryland, Baltimore County. Available at: [\[Link\]](#)
- Structure Elucidation by NMR in Organic Chemistry: A Practical Guide. (n.d.). John Wiley & Sons. Available at: [\[Link\]](#)
- SOP data acquisition. (n.d.). R-NMR. Available at: [\[Link\]](#)
- Novel Azetidine-Containing TZT-1027 Analogues as Antitumor Agents. (2018). MDPI. Available at: [\[Link\]](#)
- Protonation Kinetics in Proteins at Basic pH Determined by pH-Dependent NMR Relaxation Reveal the Entire Relationship between Kinetics and pKa Values. (2025). PubMed Central. Available at: [\[Link\]](#)
- NMR Data Acquisition and Processing Procedure. (n.d.). University of Wisconsin-Madison. Available at: [\[Link\]](#)

- NMR Data Processing. (n.d.). University of Cambridge. Available at: [\[Link\]](#)
- Protonation Kinetics in Proteins at Basic pH Determined by pH-Dependent NMR Relaxation Reveal the Entire Relationship between Kinetics and pKa Values. (2025). ACS Publications. Available at: [\[Link\]](#)
- pH Effects Can Dominate Chemical Shift Perturbations in $^1\text{H},^{15}\text{N}$ -HSQC NMR Spectroscopy for Studies of Small Molecule/ α -Synuclein Interactions. (2023). National Institutes of Health. Available at: [\[Link\]](#)
- NMR sample preparation guidelines. (2025). NMR-Bio. Available at: [\[Link\]](#)
- Sample Preparation - NMR. (n.d.). University of Alberta. Available at: [\[Link\]](#)
- Structural environments of carboxyl groups in natural organic molecules from terrestrial systems. Part 2: 2D NMR spectroscopy. (n.d.). University of Toronto. Available at: [\[Link\]](#)
- 2D NMR spectroscopy for structural elucidation of complex small molecules. (2020). YouTube. Available at: [\[Link\]](#)
- NMR as a Tool for Structure Elucidation of Organic Compounds. (n.d.). Wesleyan University. Available at: [\[Link\]](#)
- Structure elucidation from 2D NMR spectra using the StrucEluc expert system: detection and removal of contradictions in the data. (n.d.). PubMed. Available at: [\[Link\]](#)
- Protein NMR Sample Requirements. (n.d.). Michigan State University. Available at: [\[Link\]](#)
- ^1H - and ^{13}C -NMR chemical shifts for compound 7. (n.d.). ResearchGate. Available at: [\[Link\]](#)
- A Step-By-Step Guide to 1D and 2D NMR Interpretation. (2018). Emery Pharma. Available at: [\[Link\]](#)
- 2D NMR Spectroscopy: COSY, HSQC (HMQC) and HMBC. (2020). YouTube. Available at: [\[Link\]](#)
- Understanding 2D NMR Spectra: How to Read and Interpret Them. (n.d.). Creative Biostructure. Available at: [\[Link\]](#)

- cosy hsqc hmhc: Topics by Science.gov. (n.d.). Science.gov. Available at: [\[Link\]](#)
- Common 2D (COSY, HSQC, HMBC). (n.d.). San Diego State University NMR Facility. Available at: [\[Link\]](#)
- Synthesis and Characterization of Alkylammonium Zwitterionic Amino Acids Derivatives by FTIR, NMR Spectroscopy and DFT Calculations. (2014). PubMed. Available at: [\[Link\]](#)
- Combination of ¹H and ¹³C NMR Spectroscopy. (n.d.). ResearchGate. Available at: [\[Link\]](#)
- Spectroscopy of Carboxylic Acids and Nitriles. (n.d.). NC State University Libraries. Available at: [\[Link\]](#)
- ¹H NMR Chemical Shift. (n.d.). Oregon State University. Available at: [\[Link\]](#)

Need Custom Synthesis?

BenchChem offers custom synthesis for rare earth carbides and specific isotopic labeling.

Email: info@benchchem.com or [Request Quote Online](#).

Sources

- 1. NMR as a Tool for Structure Elucidation of Organic Compounds Not Offered CHEM 385 [\[owaprod-pub.wesleyan.edu\]](#)
- 2. [pdf.benchchem.com](#) [\[pdf.benchchem.com\]](#)
- 3. Synthesis of New Azetidine and Oxetane Amino Acid Derivatives through Aza-Michael Addition of NH-Heterocycles with Methyl 2-(Azetidino- or Oxetan-3-ylidene)acetates - PMC [\[pmc.ncbi.nlm.nih.gov\]](#)
- 4. 20.8 Spectroscopy of Carboxylic Acids and Nitriles – Organic Chemistry: A Tenth Edition – OpenStax adaptation 1 [\[ncstate.pressbooks.pub\]](#)
- 5. ¹H NMR Chemical Shift [\[sites.science.oregonstate.edu\]](#)
- 6. [royalsocietypublishing.org](#) [\[royalsocietypublishing.org\]](#)
- 7. [bmrbl.io](#) [\[bmrbl.io\]](#)
- 8. [pubs.acs.org](#) [\[pubs.acs.org\]](#)

- [9. myneni.princeton.edu](http://9.myneni.princeton.edu) [myneni.princeton.edu]
- [10. Sample Preparation](http://10.SamplePreparation.nmr.chem.ualberta.ca) [nmr.chem.ualberta.ca]
- [11. NMR Sample Preparation | NMR and Chemistry MS Facilities](http://11.NMRSamplePreparation.NMRandChemistryMSFacilities.nmr.chem.cornell.edu) [nmr.chem.cornell.edu]
- [12. sites.esa.ipb.pt](http://12.sites.esa.ipb.pt) [sites.esa.ipb.pt]
- [13. creative-biostructure.com](http://13.creative-biostructure.com) [creative-biostructure.com]
- [14. 7\) Common 2D \(COSY, HSQC, HMBC\) | SDSU NMR Facility – Department of Chemistry](http://14.7)Common2D(COSY,HSQC,HMBC)|SDSUNMRFacility-DepartmentofChemistry.nmr.sdsu.edu) [nmr.sdsu.edu]
- [15. m.youtube.com](http://15.m.youtube.com) [m.youtube.com]
- [16. emerypharma.com](http://16.emerypharma.com) [emerypharma.com]
- To cite this document: BenchChem. [Application Note: Comprehensive NMR-Based Structural Characterization of N-isopropylazetidine-2-carboxylic acid]. BenchChem, [2026]. [Online PDF]. Available at: [\[https://www.benchchem.com/product/b1504832/docs#application-note-comprehensive-nmr-based-structural-characterization-of-n-isopropylazetidine-2-carboxylic-acid\]](https://www.benchchem.com/product/b1504832/docs#application-note-comprehensive-nmr-based-structural-characterization-of-n-isopropylazetidine-2-carboxylic-acid)

Disclaimer & Data Validity:

The information provided in this document is for Research Use Only (RUO) and is strictly not intended for diagnostic or therapeutic procedures. While BenchChem strives to provide accurate protocols, we make no warranties, express or implied, regarding the fitness of this product for every specific experimental setup.

Technical Support: The protocols provided are for reference purposes. Unsure if this reagent suits your experiment?

Need Industrial/Bulk Grade? [Request Custom Synthesis Quote](#)

BenchChem

Our mission is to be the trusted global source of essential and advanced chemicals, empowering scientists and researchers to drive progress in science and industry.

Contact

Address: 3281 E Guasti Rd
Ontario, CA 91761, United States
Phone: (601) 213-4426
Email: info@benchchem.com

Contact our Ph.D. Support Team for a compatibility check