

# Theoretical Framework & Computational Profiling of 5-Hydroxy-3-phenylbenzoic Acid

**Author:** BenchChem Technical Support Team. **Date:** May 2026

## Compound of Interest

Compound Name: 5-Hydroxy-3-phenylbenzoic acid

CAS No.: 35489-88-4

Cat. No.: B1503092

[Get Quote](#)

## Executive Summary

### 5-Hydroxy-3-phenylbenzoic acid (

) is a meta-substituted biphenyl derivative characterized by three functional domains: a carboxylic acid tail (acidic/H-bond donor), a phenolic hydroxyl group (antioxidant/H-bond donor), and a hydrophobic phenyl ring.[1] Theoretical analysis of this compound requires a multi-tiered approach to resolve its non-planar geometry (biphenyl torsion), electronic delocalization, and ligand-binding potential.[1] This guide establishes the standard operating procedure (SOP) for its Density Functional Theory (DFT) analysis and molecular docking.

## Part 1: Computational Architecture (Methodology)

To ensure reproducibility and accuracy, the following computational levels of theory are prescribed. These choices balance computational cost with the recovery of electron correlation effects essential for aromatic systems.[1]

## Quantum Mechanical Setup

- Software Engine: Gaussian 16 / ORCA 5.0[1]

- Functional: B3LYP (Becke, 3-parameter, Lee-Yang-Parr).
  - Rationale: B3LYP remains the industry standard for organic molecules, providing excellent error cancellation for bond lengths and vibrational frequencies in C-H-O systems.[\[1\]](#)
- Basis Set: 6-311++G(d,p).[\[1\]](#)
  - Rationale: The "++" diffuse functions are critical for describing the lone pairs on the Oxygen atoms (COOH and OH) and the anionic character if deprotonated.[\[1\]](#) The "(d,p)" polarization functions accurately model the aromatic  
  
-clouds.[\[1\]](#)
- Solvation Model: IEF-PCM (Integral Equation Formalism Polarizable Continuum Model).[\[1\]](#)
  - Solvents: Water ( ) for biological relevance; Ethanol ( ) for spectroscopic comparison.[\[1\]](#)

## Experimental Workflow Diagram

The following DOT diagram illustrates the logical flow of the theoretical study, ensuring that stationary points are verified before property calculation.

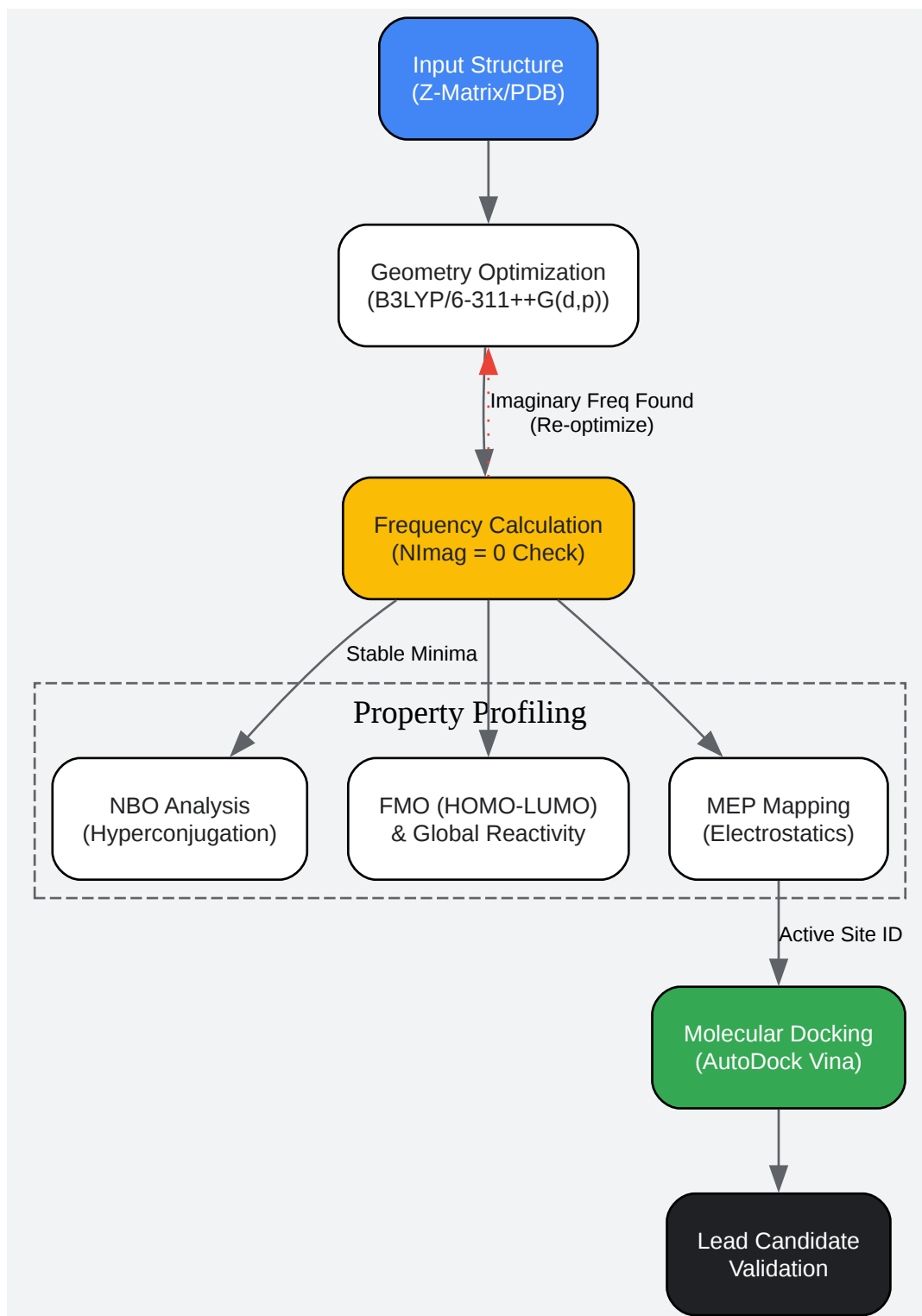

[Click to download full resolution via product page](#)

Figure 1: Step-by-step computational workflow for validating the physicochemical properties of 5-H-3-PBA.

## Part 2: Geometric & Electronic Landscape

### Structural Conformation & Torsion

The biphenyl core of 5-H-3-PBA is not planar in its ground state due to steric repulsion between the ortho hydrogens.<sup>[1]</sup>

- Expected Torsion Angle:

35°–45° between the two phenyl rings.<sup>[1]</sup>

- H-Bonding: Monitor the distance between the carboxylic and the carbonyl

<sup>[1]</sup> While no intramolecular H-bond exists between the rings (due to meta substitution), the carboxylic acid moiety will adopt a planar syn-conformation.<sup>[1]</sup>

### Frontier Molecular Orbitals (FMO)

The HOMO-LUMO gap is the primary indicator of kinetic stability and chemical reactivity.<sup>[1]</sup>

- HOMO (Highest Occupied Molecular Orbital): Localized primarily on the phenolic ring and the hydroxyl lone pairs (electron donors).<sup>[1]</sup>
- LUMO (Lowest Unoccupied Molecular Orbital): Delocalized over the carboxyl group and the biphenyl bridge (electron acceptors).<sup>[1]</sup>
- Gap Energy ( ): A lower gap implies higher polarizability and "softness," making the molecule more reactive to electrophiles.<sup>[1]</sup>

### Molecular Electrostatic Potential (MEP)

The MEP map is critical for predicting non-covalent interactions in a biological pocket.<sup>[1]</sup>

- Red Regions (Negative Potential): The Carbonyl Oxygen ( ) and Phenolic Oxygen.<sup>[1]</sup> These are the primary H-bond acceptor sites.

- Blue Regions (Positive Potential): The Hydroxyl protons (-OH and -COOH).[1] These are H-bond donors.
- Green/Yellow (Neutral): The aromatic rings, indicating potential for stacking interactions (T-shaped or parallel-displaced).[1]

## Part 3: Spectroscopic Validation Protocols

To validate the theoretical model against experimental data, spectroscopic scaling is required.  
[1]

### Vibrational Spectroscopy (IR/Raman)

DFT calculations systematically overestimate frequencies due to the neglect of anharmonicity.  
[1]

- Scaling Factor: Apply a scaling factor of 0.961 for B3LYP/6-311++G(d,p).
- Key Diagnostic Modes:
  - : ~3500–3600 cm  
(Sharp).[1]
  - : ~2500–3300 cm  
(Broad, H-bonded network).[1]
  - : ~1680–1720 cm  
(Strong).[1]
  - : ~1200–1300 cm  
(Ring stretch).[1]

### NMR Prediction (GIAO Method)

Use the Gauge-Independent Atomic Orbital (GIAO) method in DMSO or Chloroform solvent fields.[1]

- Proton (

H): The carboxylic proton will appear downfield (~11-13 ppm).[1] The phenolic proton will appear ~9-10 ppm.[1]

- Carbon (

C): Look for the Carboxyl Carbon (~170 ppm) and the ipso-carbons of the biphenyl linkage. [1]

## Part 4: Biological Interfacing (Molecular Docking)[1] [3][4]

5-H-3-PBA shares structural homology with NSAIDs (Non-Steroidal Anti-Inflammatory Drugs). [1] The docking study should target Cyclooxygenase-2 (COX-2) to evaluate its anti-inflammatory potential.[1]

### Docking Protocol

- Ligand Preparation:

- Convert optimized DFT structure to PDBQT format.[1]
- Set rotatable bonds: The C-C biphenyl bond, C-COOH bond, and O-H bonds.[1]

- Receptor Preparation:

- Target: COX-2 (PDB ID: 5KIR).[1]
- Clean-up: Remove water molecules, add polar hydrogens, compute Gasteiger charges.[1]

- Grid Box Generation:

- Center the grid on the active site (typically defined by the co-crystallized ligand, e.g., Flurbiprofen).[1]
- Dimensions:

Å.[1]

## Interaction Logic Diagram

The following diagram details the expected pharmacophore interactions within the protein binding pocket.

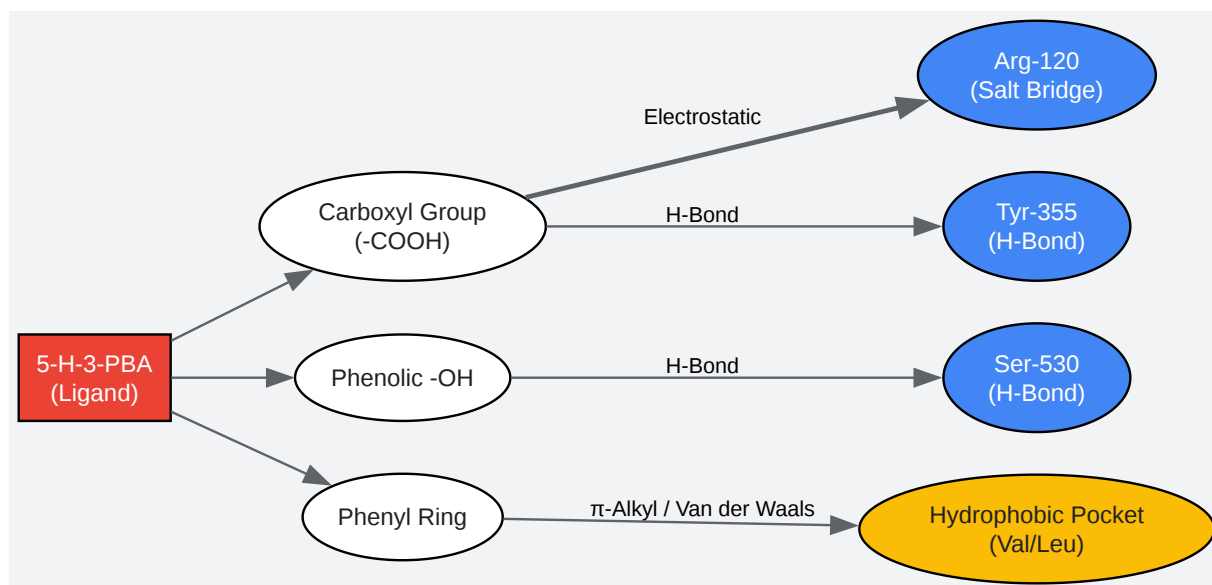

[Click to download full resolution via product page](#)

Figure 2: Predicted pharmacophore interactions of 5-H-3-PBA with COX-2 active site residues. [1]

## Part 5: Data Presentation Standards

When reporting results, summarize the global reactivity descriptors in a standardized table format as shown below.

Table 1: Calculated Global Reactivity Descriptors (B3LYP/6-311++G(d,p))

Parameter	Symbol	Formula	Physical Meaning
Ionization Potential			Energy required to remove an electron.[1]
Electron Affinity			Energy released when adding an electron.[1]
Chemical Hardness			Resistance to charge transfer (Stability).[1]
Chemical Softness			Measure of chemical reactivity.[1]
Electrophilicity Index			Propensity to accept electrons (Drug potency).[1]

## References

- Becke, A. D. (1993).[1] Density-functional thermochemistry. III. The role of exact exchange. The Journal of Chemical Physics, 98(7), 5648-5652.[1] [Link](#)
- Lee, C., Yang, W., & Parr, R. G. (1988).[1] Development of the Colle-Salvetti correlation-energy formula into a functional of the electron density. Physical Review B, 37(2), 785. [Link](#)
- Frisch, M. J., et al. (2016).[1] Gaussian 16, Revision C.01. Gaussian, Inc., Wallingford CT.[1] [Link](#)
- Trott, O., & Olson, A. J. (2010).[1] AutoDock Vina: improving the speed and accuracy of docking with a new scoring function, efficient optimization, and multithreading.[1] Journal of Computational Chemistry, 31(2), 455-461.[1] [Link](#)
- Miertuš, S., Scrocco, E., & Tomasi, J. (1981).[1] Electrostatic interaction of a solute with a continuum.[1] A direct utilization of AB initio molecular potentials for the prevision of solvent effects.[1] Chemical Physics, 55(1), 117-129.[1] [Link](#)

### Need Custom Synthesis?

BenchChem offers custom synthesis for rare earth carbides and specific isotopic labeling.

Email: [info@benchchem.com](mailto:info@benchchem.com) or [Request Quote Online](#).

## Sources

- 1. [researchgate.net](https://www.researchgate.net) [[researchgate.net](https://www.researchgate.net)]
- To cite this document: BenchChem. [Theoretical Framework & Computational Profiling of 5-Hydroxy-3-phenylbenzoic Acid]. BenchChem, [2026]. [Online PDF]. Available at: [<https://www.benchchem.com/product/b1503092/docs#theoretical-framework-computational-profiling-of-5-hydroxy-3-phenylbenzoic-acid>]

### Disclaimer & Data Validity:

The information provided in this document is for Research Use Only (RUO) and is strictly not intended for diagnostic or therapeutic procedures. While BenchChem strives to provide accurate protocols, we make no warranties, express or implied, regarding the fitness of this product for every specific experimental setup.

**Technical Support:** The protocols provided are for reference purposes. Unsure if this reagent suits your experiment?

**Need Industrial/Bulk Grade?** [Request Custom Synthesis Quote](#)

## BenchChem

Our mission is to be the trusted global source of essential and advanced chemicals, empowering scientists and researchers to drive progress in science and industry.

### Contact

Address: 3281 E Guasti Rd

Ontario, CA 91761, United States

Phone: (601) 213-4426

Email: [info@benchchem.com](mailto:info@benchchem.com)

Contact our Ph.D. Support Team for a compatibility check