

Validation of Dopamine Acrylamide as a Neural Interface Material: A Comparative Guide

Author: BenchChem Technical Support Team. **Date:** April 2026

Compound of Interest

Compound Name: Dopamine acrylamide

Cat. No.: B1502722

[Get Quote](#)

For Researchers, Scientists, and Drug Development Professionals

The development of biocompatible and high-performance neural interface materials is critical for advancing neuroscience research and creating next-generation neuroprosthetics.

Dopamine acrylamide has emerged as a promising candidate due to its unique combination of conductivity, biocompatibility, and adhesive properties inspired by mussel foot proteins. This guide provides an objective comparison of **dopamine acrylamide** with other commonly used neural interface materials, supported by experimental data and detailed protocols.

Performance Comparison of Neural Interface Materials

The selection of a neural interface material depends on a balance of electrochemical performance, biocompatibility, and long-term stability. The following table summarizes key quantitative data for **dopamine acrylamide**-based hydrogels and compares them with established materials such as PEDOT:PSS, silicon, and Parylene-C.

Material	Key Performance Metric	Value	Alternative Materials	Alternative Metric Value
Dopamine Acrylamide Hydrogel	Signal-to-Noise Ratio (SNR)	10-fold higher than commercial silver electrodes[1]	PEDOT:PSS	12 dB[2]
Electrochemical Impedance (1 kHz)	~7.4 kΩ (for a 400 μm diameter electrode)[2]	PEDOT:PSS	7.4 kΩ[2]	
Silicon Probes	Higher impedance, often requiring coatings to reduce it.[3]			
Parylene-C coated electrodes	Provides high impedance for insulation.[4][5]			
Biocompatibility (Cell Viability)	>75% (non-cytotoxic)[6]	PEDOT:PSS	Supports neuronal growth with reduced glial response.[7]	
Silicon	Can elicit a more significant foreign body response.[8]			
Parylene-C	Excellent biocompatibility, considered a standard for medical implants. [9]			

Adhesion Strength	Strong adhesion to various materials, including biological tissues.[10]	PEDOT:PSS	Generally requires adhesion-promoting layers.
Silicon	Lacks intrinsic tissue adhesion.		
Parylene-C	Adhesion can be a challenge on some substrates. [9]		

Signaling Pathway Interactions

Dopamine acrylamide's unique characteristic is the presence of dopamine moieties, which can directly interact with neuronal signaling pathways. Polydopamine, a related material, has been shown to activate Dopamine Receptor D1 (DRD1) and influence downstream pathways such as cAMP/PKA and RhoA, which are involved in cell adhesion and mechanotransduction. [11] This interaction could potentially modulate neuronal behavior and improve the tissue-implant interface.

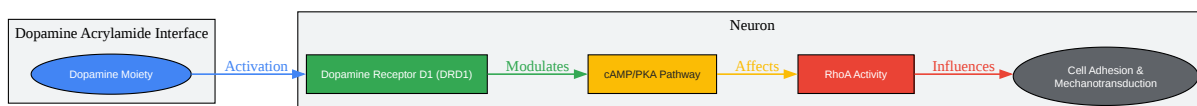

[Click to download full resolution via product page](#)

Dopamine Acrylamide's Influence on Neuronal Signaling.

Experimental Protocols

Biocompatibility Assessment: MTT Assay

This protocol assesses the cytotoxicity of the **dopamine acrylamide** hydrogel.

Materials:

- **Dopamine acrylamide** hydrogel samples (sterilized)
- Neuronal cell line (e.g., PC12, SH-SY5Y)
- Cell culture medium (e.g., DMEM)
- Fetal Bovine Serum (FBS)
- Penicillin-Streptomycin
- MTT (3-(4,5-dimethylthiazol-2-yl)-2,5-diphenyltetrazolium bromide) solution (5 mg/mL in PBS)
- Dimethyl sulfoxide (DMSO)
- 96-well plates
- Incubator (37°C, 5% CO₂)
- Microplate reader

Procedure:

- **Cell Seeding:** Seed neuronal cells in a 96-well plate at a density of 1×10^4 cells/well and incubate for 24 hours.
- **Sample Incubation:** Place sterilized **dopamine acrylamide** hydrogel samples into the wells with the cultured cells. Include a positive control (e.g., a cytotoxic substance) and a negative control (cells with medium only).
- **Incubation:** Incubate the plate for 24, 48, and 72-hour time points.

- **MTT Addition:** After each time point, remove the hydrogel samples and add 20 μL of MTT solution to each well. Incubate for 4 hours.
- **Formazan Solubilization:** Remove the medium and add 150 μL of DMSO to each well to dissolve the formazan crystals.
- **Absorbance Measurement:** Measure the absorbance at 570 nm using a microplate reader.
- **Data Analysis:** Calculate cell viability as a percentage relative to the negative control.

Electrochemical Performance: In Vitro Impedance Measurement

This protocol measures the electrochemical impedance of the neural interface material.

Materials:

- **Dopamine acrylamide** electrode
- Potentiostat with impedance spectroscopy capabilities
- Three-electrode setup: working electrode (**dopamine acrylamide** electrode), counter electrode (e.g., platinum wire), and reference electrode (e.g., Ag/AgCl)
- Phosphate-buffered saline (PBS) or artificial cerebrospinal fluid (aCSF)
- Beaker or electrochemical cell

Procedure:

- **Setup:** Assemble the three-electrode system in a beaker containing PBS or aCSF.
- **Connection:** Connect the electrodes to the potentiostat.
- **Measurement Parameters:** Set the frequency range (e.g., 1 Hz to 100 kHz) and the AC voltage amplitude (e.g., 10 mV).
- **Data Acquisition:** Run the electrochemical impedance spectroscopy measurement.

- Data Analysis: Plot the impedance magnitude and phase as a function of frequency (Bode plot). The impedance at 1 kHz is a standard metric for comparison.

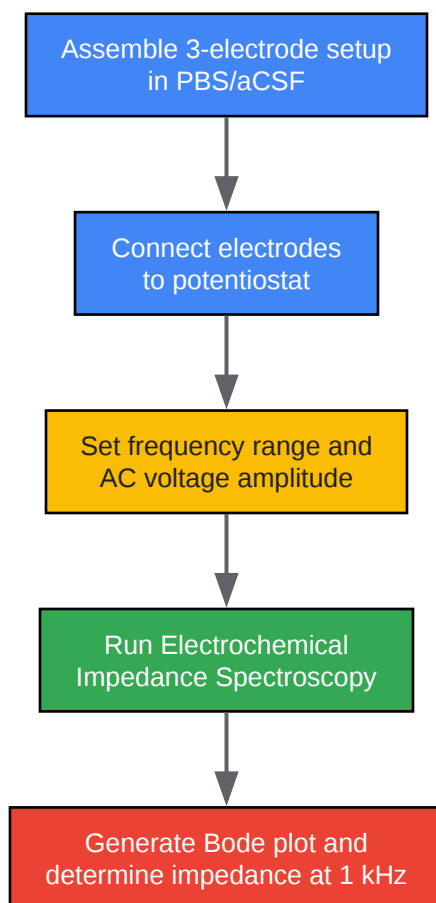

[Click to download full resolution via product page](#)

Workflow for In Vitro Impedance Measurement.

Neuronal Cell Culture on Dopamine Acrylamide Substrate

This protocol evaluates the ability of the material to support neuronal growth and network formation.

Materials:

- **Dopamine acrylamide**-coated coverslips or substrates
- Primary neurons (e.g., cortical or hippocampal neurons) or a neuronal cell line

- Poly-D-lysine (for control substrates)
- Neuronal culture medium (e.g., Neurobasal medium with B27 supplement)
- Incubator (37°C, 5% CO₂)
- Microscope with fluorescence capabilities
- Immunostaining reagents (e.g., antibodies for neuronal markers like β -III tubulin and MAP2)

Procedure:

- **Substrate Preparation:** Sterilize the **dopamine acrylamide** substrates and place them in a culture plate. Prepare control substrates coated with poly-D-lysine.
- **Cell Seeding:** Dissociate and plate the neurons onto the substrates at a desired density.
- **Cell Culture:** Culture the neurons for a specified period (e.g., 7-14 days), changing the medium as required.
- **Morphology Assessment:** At different time points, observe cell adhesion, neurite outgrowth, and network formation using phase-contrast microscopy.
- **Immunocytochemistry:** After the culture period, fix the cells and perform immunostaining for neuronal markers to visualize and quantify neuronal morphology and synapse formation.
- **Imaging and Analysis:** Acquire images using a fluorescence microscope and analyze parameters such as neurite length, branching, and number of synaptic puncta.

Conclusion

Dopamine acrylamide demonstrates significant potential as a neural interface material, offering a unique combination of favorable electrochemical properties, excellent biocompatibility, and inherent bio-adhesion. Its ability to potentially interact with and modulate neuronal signaling pathways opens new avenues for creating more integrated and effective neural interfaces. While the neurotoxicity of the acrylamide monomer is a concern that requires careful management during synthesis to ensure complete polymerization and removal of unreacted monomers^{[12][13]}, the resulting polymer has shown promising biocompatibility.

Further long-term in vivo studies are warranted to fully validate its chronic performance and stability against materials like silicon and Parylene-C. However, the existing data strongly supports its continued investigation and development for a wide range of applications in neuroscience and neurotechnology.

Need Custom Synthesis?

BenchChem offers custom synthesis for rare earth carbides and specific isotopic labeling.

Email: info@benchchem.com or [Request Quote Online](#).

References

- [1. Dopamine-integrated all-hydrogel multi-electrode arrays for neural activity recording - Materials Horizons \(RSC Publishing\) \[pubs.rsc.org\]](#)
- [2. Effect of acrylamide on neurotransmitter metabolism and neuropeptide levels in several brain regions and upon circulating hormones - PubMed \[pubmed.ncbi.nlm.nih.gov\]](#)
- [3. Revolutionizing brain–computer interfaces: overcoming biocompatibility challenges in implantable neural interfaces - PMC \[pmc.ncbi.nlm.nih.gov\]](#)
- [4. mdpi.com \[mdpi.com\]](#)
- [5. Encapsulation of an integrated neural interface device with Parylene C - PubMed \[pubmed.ncbi.nlm.nih.gov\]](#)
- [6. Dopamine: Functions, Signaling, and Association with Neurological Diseases - PMC \[pmc.ncbi.nlm.nih.gov\]](#)
- [7. pubs.acs.org \[pubs.acs.org\]](#)
- [8. Frontiers | In vivo Recording Quality of Mechanically Decoupled Floating Versus Skull-Fixed Silicon-Based Neural Probes \[frontiersin.org\]](#)
- [9. api.repository.cam.ac.uk \[api.repository.cam.ac.uk\]](#)
- [10. researchgate.net \[researchgate.net\]](#)
- [11. Activation of Dopamine Receptor D1 and Downstream Cellular Functions by Polydopamine - PubMed \[pubmed.ncbi.nlm.nih.gov\]](#)
- [12. Chronic acrylamide exposure resulted in dopaminergic neuron loss, neuroinflammation and motor impairment in rats - PubMed \[pubmed.ncbi.nlm.nih.gov\]](#)

- [13. Review on Chronic Exposure of Acrylamide Causes a Neurotoxicity Risk \[accscience.com\]](#)
- To cite this document: BenchChem. [Validation of Dopamine Acrylamide as a Neural Interface Material: A Comparative Guide]. BenchChem, [2026]. [Online PDF]. Available at: [\[https://www.benchchem.com/product/b1502722/docs#validation-of-dopamine-acrylamide-as-a-neural-interface-material-a-comparative-guide\]](https://www.benchchem.com/product/b1502722/docs#validation-of-dopamine-acrylamide-as-a-neural-interface-material-a-comparative-guide)

Disclaimer & Data Validity:

The information provided in this document is for Research Use Only (RUO) and is strictly not intended for diagnostic or therapeutic procedures. While BenchChem strives to provide accurate protocols, we make no warranties, express or implied, regarding the fitness of this product for every specific experimental setup.

Technical Support: The protocols provided are for reference purposes. Unsure if this reagent suits your experiment?

Need Industrial/Bulk Grade? [Request Custom Synthesis Quote](#)

BenchChem

Our mission is to be the trusted global source of essential and advanced chemicals, empowering scientists and researchers to drive progress in science and industry.

Contact

Address: 3281 E Guasti Rd
Ontario, CA 91761, United States
Phone: (601) 213-4426
Email: info@benchchem.com

[Contact our Ph.D. Support Team for a compatibility check](#)