

Technical Guide: LCMS Structural Elucidation of Ethyl 2-bromo-6-chloronicotinate

Author: BenchChem Technical Support Team. **Date:** May 2026

Compound of Interest

Compound Name: Ethyl 2-bromo-6-chloronicotinate
CAS No.: 1214377-13-5
Cat. No.: B1502949

[Get Quote](#)

Executive Summary

This guide provides a structural elucidation framework for **Ethyl 2-bromo-6-chloronicotinate**, a critical intermediate in the synthesis of agrochemicals and pyridine-based pharmaceuticals.

Unlike simple organic esters, this molecule presents a unique analytical challenge due to the competing ionization behaviors of the basic pyridine nitrogen and the electron-withdrawing halogen substituents. This guide compares ionization modes (ESI vs. APCI) and details the specific isotopic and fragmentation signatures required for confident identification in complex matrices.

Structural Context & Isotopic Fingerprint

Before analyzing fragmentation, the analyst must validate the precursor ion using the unique isotopic signature conferred by the presence of one Bromine and one Chlorine atom.

The "3:4:1" Isotopic Rule

The combination of naturally occurring

(~1:1) and

(~3:1) creates a distinct spectral pattern that serves as a self-validating check for the molecular formula

- M (m/z ~263.9): Contains

and

- M+2 (m/z ~265.9): A "mixed" peak containing both (

) and (

). This is theoretically the most intense peak.

- M+4 (m/z ~267.9): Contains

and

Theoretical Intensity Ratio:

“

Critical Check: If your MS spectrum shows a 1:1 doublet (Br only) or a 3:1 pattern (Cl only), the synthesis has failed (e.g., dehalogenation has occurred).

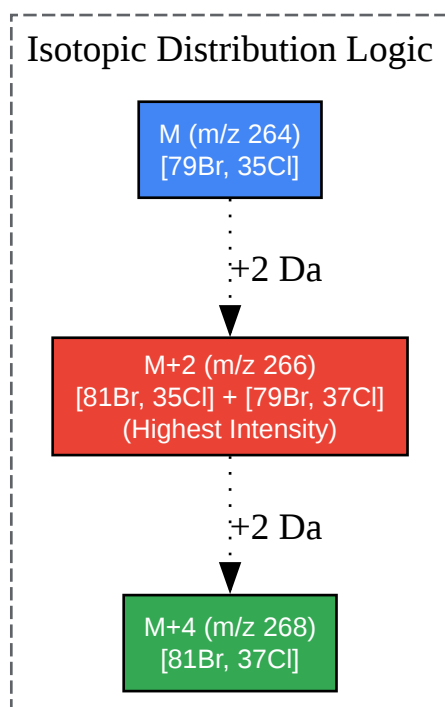

[Click to download full resolution via product page](#)

Figure 1: Theoretical isotopic distribution logic for a single Br/Cl substituted molecule.

Comparative Analysis: Ionization Modes

Selecting the correct ionization source is pivotal for sensitivity. While Pyridines are traditionally analyzed via Electrospray Ionization (ESI), the halogens on positions 2 and 6 significantly reduce the basicity of the ring nitrogen.

Performance Matrix: ESI vs. APCI[1][2]

Feature	ESI (Electrospray Ionization)	APCI (Atmospheric Pressure Chemical Ionization)	Recommendation
Mechanism	Solution-phase protonation ().	Gas-phase proton transfer.	ESI is primary.[1]
Sensitivity	High. Despite halogens, the pyridine N lone pair remains sufficiently basic for protonation in acidic mobile phases (0.1% Formic Acid).	Medium. Effective, but often produces higher background noise for this specific mass range (< 300 Da).	Use ESI for trace analysis.[2][1]
Adducts	Prone to and if buffers are not strictly controlled.	Predominantly ; fewer salt adducts.	APCI preferred if salt interference is high.
Fragmentation	"Softer" ionization; preserves the molecular ion.	Harder ionization; may induce thermal degradation (decarboxylation) before MS/MS.	ESI for structural confirmation.

Conclusion: Start with ESI(+). Switch to APCI only if matrix suppression (from non-polar reaction solvents like toluene) is observed.

Fragmentation Mechanism (MS/MS)[4][5][6][7][8][9][10][11]

Once the precursor

($m/z \sim 264$) is isolated, Collision Induced Dissociation (CID) yields a predictable fragmentation tree. The fragmentation is driven by the stability of the pyridine ring and the lability of the ethyl ester.

Primary Pathways

- Neutral Loss of Ethene (McLafferty-like): The ethyl group rearranges to lose neutral ethene (-28 Da), resulting in the protonated carboxylic acid.
- Neutral Loss of Ethanol: Direct cleavage of the ethoxy group (-46 Da) to form the acylium ion.
- Halogen Radical Loss: In higher energy collisions, the C-Br bond (weaker than C-Cl) will cleave, leading to characteristic mass shifts.

Pathway Visualization

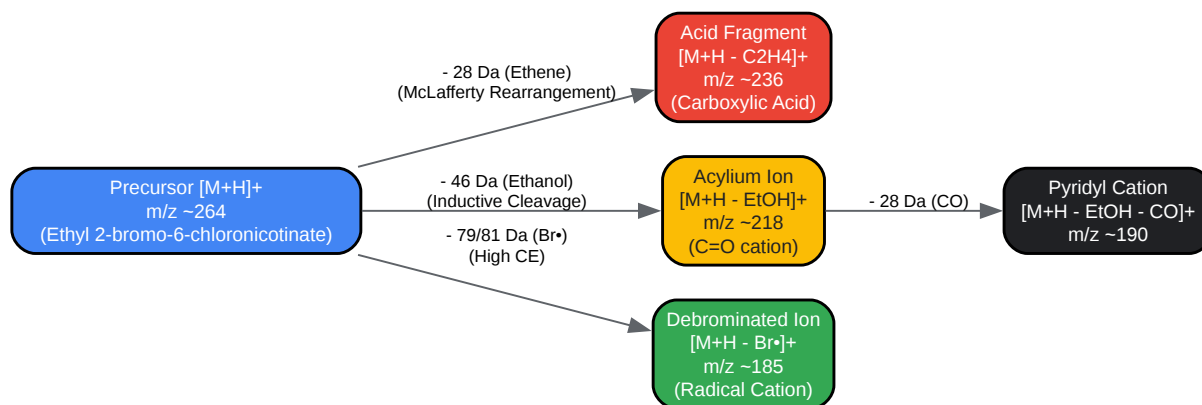

[Click to download full resolution via product page](#)

Figure 2: Proposed MS/MS fragmentation tree for **Ethyl 2-bromo-6-chloronicotinate** under ESI+ conditions.

Experimental Protocol

This protocol is designed for self-validation. It ensures that the instrument captures the isotopic data necessary to confirm the halogenation state before attempting structural elucidation.

LC Conditions

- Column: C18 Reverse Phase (e.g., Agilent ZORBAX Eclipse Plus, 2.1 x 50mm, 1.8 μ m).
- Mobile Phase A: Water + 0.1% Formic Acid (Promotes protonation).
- Mobile Phase B: Acetonitrile + 0.1% Formic Acid.
- Gradient: 5% B to 95% B over 5 minutes. (Halogenated esters are moderately lipophilic and will elute late, typically >3 min).

MS Parameters (Triple Quadrupole / Q-TOF)

- Source: ESI Positive Mode.
- Scan Type:
 - Full Scan (MS1): m/z 100 – 500. Purpose: Confirm 3:4:1 isotope pattern.
 - Product Ion Scan (MS2): Precursor m/z 263.9 (choose the monoisotopic peak).
- Collision Energy (CE): Ramp 10 – 40 eV.
 - Low CE (10-15 eV): Favors Ester cleavage (m/z 236, 218).
 - High CE (>30 eV): Favors Halogen loss and ring fragmentation.

Data Interpretation Steps

- Check Isotope Pattern: Does the MS1 spectrum at RT ~3.5 min show the 3:4:1 ratio?
 - If yes: Proceed.
 - If no: Check for hydrolysis (Acid form) or dehalogenation.

- Verify Neutral Loss: Look for the -28 Da (Ethene) and -46 Da (Ethanol) transitions. These confirm the ethyl ester moiety is intact.
- Check Halogen Integrity: Ensure the daughter ions retain the Chlorine isotope pattern (3:1) if Bromine is lost, or lose the pattern entirely if the ring fragments.

References

- Sparkman, O. D. (2005). Mass Spectrometry Desk Reference. Global View Publishing.
- Holčapek, M., et al. (2010). "Structural analysis of small organic molecules by mass spectrometry." Trends in Analytical Chemistry.
- NIST Mass Spectrometry Data Center. "Fragmentation of Pyridine Carboxylates." NIST Chemistry WebBook, SRD 69. [[Link](#)]
- Agilent Technologies. (2020). "Technical Overview: Optimizing ESI Parameters for Halogenated Heterocycles." [[Link](#)]

Need Custom Synthesis?

BenchChem offers custom synthesis for rare earth carbides and specific isotopic labeling.

Email: info@benchchem.com or [Request Quote Online](#).

Sources

1. m.youtube.com [m.youtube.com]
2. Comparison of ESI– and APCI–LC–MS/MS methods: A case study of levonorgestrel in human plasma - PMC [[pmc.ncbi.nlm.nih.gov](https://pubmed.ncbi.nlm.nih.gov)]
- To cite this document: BenchChem. [Technical Guide: LCMS Structural Elucidation of Ethyl 2-bromo-6-chloronicotinate]. BenchChem, [2026]. [Online PDF]. Available at: [<https://www.benchchem.com/product/b1502949/docs#technical-guide-lcms-structural-elucidation-of-ethyl-2-bromo-6-chloronicotinate>]

Disclaimer & Data Validity:

The information provided in this document is for Research Use Only (RUO) and is strictly not intended for diagnostic or therapeutic procedures. While BenchChem strives to provide accurate protocols, we make no warranties, express or implied, regarding the fitness of this product for every specific experimental setup.

Technical Support: The protocols provided are for reference purposes. Unsure if this reagent suits your experiment?

Need Industrial/Bulk Grade? [Request Custom Synthesis Quote](#)

BenchChem

Our mission is to be the trusted global source of essential and advanced chemicals, empowering scientists and researchers to drive progress in science and industry.

Contact

Address: 3281 E Guasti Rd
Ontario, CA 91761, United States
Phone: (601) 213-4426
Email: info@benchchem.com

[Contact our Ph.D. Support Team for a compatibility check](#)