

# Application Note: A Comprehensive Guide to the Chromatographic Separation of Chromene Esters

**Author:** BenchChem Technical Support Team. **Date:** May 2026

## Compound of Interest

Compound Name:	<i>6-Bromo-8-methoxy-2H-chromene-3-carboxylic acid methyl ester</i>
CAS No.:	885271-18-1
Cat. No.:	B1501960

[Get Quote](#)

## Abstract

Chromene esters represent a vital class of heterocyclic compounds, forming the structural core of numerous natural products and pharmacologically active molecules.[1][2] Their synthesis and isolation are pivotal in drug discovery and development, demanding robust and efficient purification and analytical techniques. The inherent structural diversity of chromene esters, including the frequent presence of chiral centers, necessitates a tailored approach to their chromatographic separation. This guide provides a detailed exploration of the primary chromatographic techniques for the separation of chromene esters, intended for researchers, chemists, and drug development professionals. We delve into the causality behind methodological choices, offering field-proven protocols for preparative-scale flash chromatography, high-resolution achiral and chiral High-Performance Liquid Chromatography (HPLC), and the advanced, sustainable technique of Supercritical Fluid Chromatography (SFC). Each section is designed to be a self-validating system, grounding protocols in

established scientific principles to empower users to adapt and optimize these methods for their specific molecular targets.

## Foundational Principles & Method Selection

The successful separation of chromene esters hinges on understanding their physicochemical properties, primarily their polarity and, when applicable, their stereochemistry. The ester and chromene ether functionalities typically impart moderate polarity, making them ideal candidates for normal-phase chromatography. However, the overall polarity can be significantly modulated by other substituents on the chromene ring system. For chiral chromene esters, which may exhibit vastly different biological activities between enantiomers, enantioselective chromatography is not just an analytical step but a critical requirement for pharmacological studies.<sup>[3]</sup>

The choice of chromatographic technique is dictated by the primary objective: high-throughput purification after a chemical synthesis, or high-resolution analysis for purity assessment and enantiomeric excess determination.

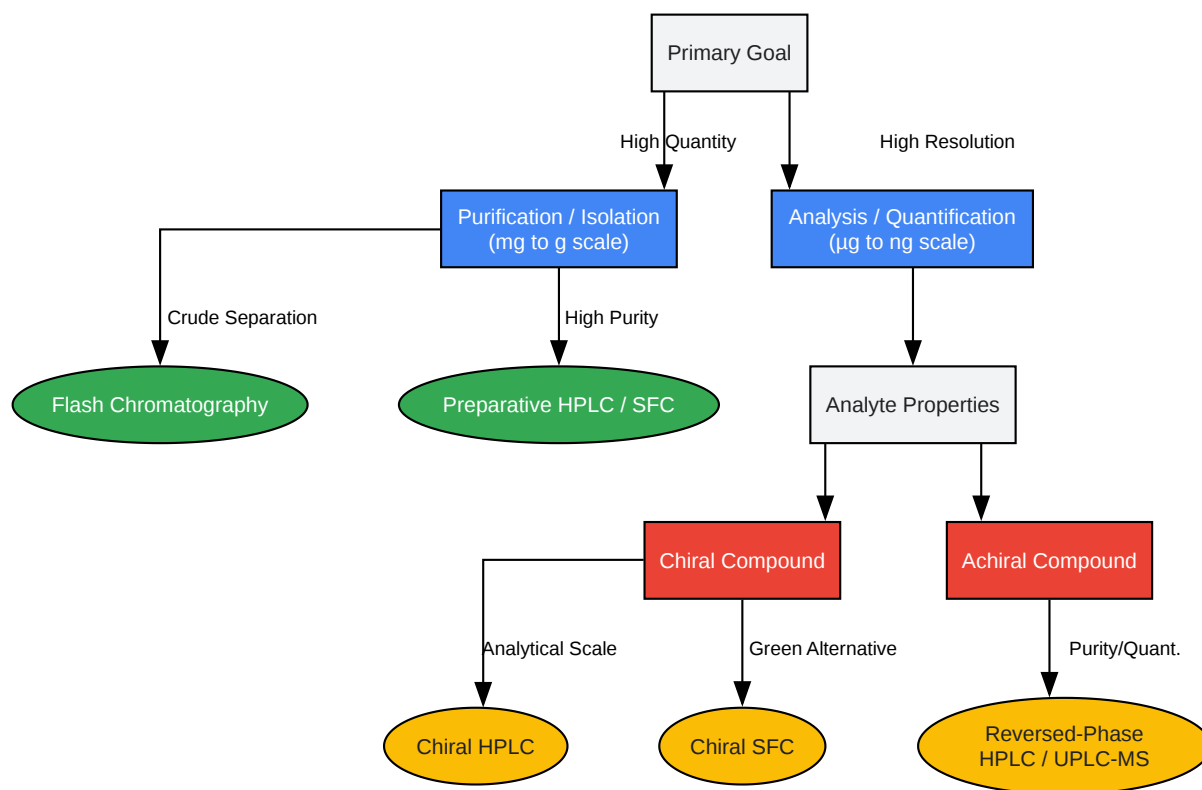

[Click to download full resolution via product page](#)

Caption: Workflow for selecting the appropriate chromatographic method.

## Preparative Scale Purification: Flash Chromatography

Flash chromatography is the workhorse for the routine purification of synthesized chromene esters, enabling the rapid separation of milligrams to grams of material.[4][5] The technique relies on an adsorption-desorption mechanism, where compounds are separated based on their affinity for a polar stationary phase, typically silica gel.[4]

### Protocol 1: Step-by-Step Flash Chromatography Purification

This protocol outlines a general procedure for purifying a moderately polar chromene ester from a crude reaction mixture.

### 1. Method Development via Thin-Layer Chromatography (TLC):

- Causality: TLC is a rapid, low-cost method to scout for an optimal solvent system. The goal is to find a mobile phase composition that provides good separation between the target compound and its major impurities, with an ideal Retention Factor ( $R_f$ ) of 0.2-0.4 for the target.<sup>[6][7]</sup> An  $R_f$  in this range ensures the compound will elute in a reasonable time from the column without excessive band broadening.
- Procedure:
  - Dissolve a small aliquot of the crude mixture in a solvent like dichloromethane or ethyl acetate.
  - Spot the solution onto a silica gel TLC plate.
  - Develop the plate in a series of solvent systems with varying polarity, such as different ratios of hexane and ethyl acetate (e.g., 9:1, 4:1, 2:1).
  - Visualize the spots using a UV lamp (254 nm) and/or a chemical stain.
  - Select the solvent system that provides the best separation and the target  $R_f$  value.

### 2. Column Packing (Wet Slurry Method):

- Causality: The wet slurry method ensures a homogeneously packed column bed, free of cracks and air bubbles, which is essential for achieving good separation efficiency.
- Procedure:
  - Select a column of appropriate size for the amount of crude material.
  - Place a small plug of cotton or glass wool at the bottom, followed by a thin layer of sand.<sup>[6]</sup>

- In a beaker, create a slurry of silica gel in the initial, least polar mobile phase chosen from the TLC analysis.
- Carefully pour the slurry into the column, allowing the solvent to drain while gently tapping the column to encourage even packing.
- Add a protective layer of sand on top of the packed silica bed.

### 3. Sample Loading:

- Causality: Concentrating the sample onto a small amount of silica (dry loading) often results in sharper bands and better separation compared to liquid loading, especially if the crude mixture has poor solubility in the mobile phase.[8]
- Procedure (Dry Loading):
  - Dissolve the crude mixture in a minimal amount of a volatile solvent (e.g., dichloromethane).
  - Add a small amount of silica gel to the solution and evaporate the solvent completely under reduced pressure to obtain a free-flowing powder.
  - Carefully add this powder to the top of the packed column.

### 4. Elution and Fraction Collection:

- Causality: A gradient elution, where the polarity of the mobile phase is gradually increased, is often more efficient for separating complex mixtures than an isocratic (constant composition) elution.[7]
- Procedure:
  - Begin eluting the column with the initial, low-polarity mobile phase.
  - Gradually increase the proportion of the more polar solvent (e.g., ethyl acetate) to elute compounds with higher affinity for the silica gel.

- Collect fractions sequentially and monitor the elution progress by TLC analysis of the collected fractions.
- Combine the fractions containing the pure chromene ester and remove the solvent under reduced pressure.

Solvent System (A:B)	Polarity	Typical Use Case for Chromene Esters
Hexane : Ethyl Acetate	Low to Medium	The most common starting point; excellent for separating moderately polar compounds from non-polar byproducts.
Dichloromethane : Methanol	Medium to High	Used for more polar chromene esters or those with free hydroxyl groups. A small amount of methanol (1-5%) drastically increases solvent polarity.
Toluene : Acetone	Medium	An alternative to hexane/ethyl acetate systems, can offer different selectivity.

Table 1. Common solvent systems for flash chromatography of chromene esters.

## High-Resolution Analysis: HPLC Methods

High-Performance Liquid Chromatography (HPLC) and its ultra-high-performance counterpart (UPLC) offer superior resolution and sensitivity, making them the gold standard for analytical applications.

## Achiral Separations (Reversed-Phase HPLC)

Reversed-phase HPLC is ideal for assessing the purity and quantifying chromene esters in various matrices, including in pharmacokinetic studies where samples are derived from plasma. [9][10]

## Protocol 2: UPLC-MS/MS Method for Quantification

This protocol is adapted from a validated method for the chromene derivative Inlachromene and is suitable for quantitative analysis. [10]

- Causality: This method uses a C18 stationary phase, which separates compounds based on hydrophobicity. The gradient elution from a weak solvent (water) to a strong solvent (acetonitrile) allows for the analysis of compounds with a range of polarities. The addition of formic acid improves peak shape and promotes ionization for mass spectrometry (MS) detection.
- Instrumentation: UPLC system coupled to a tandem mass spectrometer (MS/MS).
- Chromatographic Conditions:
  - Column: ACQUITY UPLC™ BEH C18 (e.g., 2.1 x 50 mm, 1.7 μm). [10][11]
  - Mobile Phase A: 0.1% (v/v) Formic Acid in Water.
  - Mobile Phase B: 0.1% (v/v) Formic Acid in Acetonitrile.
  - Gradient Program: A typical gradient might run from 5% B to 95% B over several minutes.
  - Flow Rate: 0.4 mL/min.
  - Column Temperature: 40 °C.
  - Injection Volume: 1-5 μL.
- Sample Preparation:
  - For plasma samples, a protein precipitation step is required. Add 3 volumes of cold acetonitrile containing an internal standard to 1 volume of plasma.

- Vortex and centrifuge to pellet the precipitated proteins.
- Inject the supernatant for analysis.[10]
- Detection (MS/MS):
  - Ionization Mode: Electrospray Ionization (ESI), positive mode.
  - Acquisition Mode: Multiple Reaction Monitoring (MRM) for high selectivity and sensitivity. Specific precursor-to-product ion transitions must be determined for the target chromene ester and the internal standard.[10]

Parameter	Typical Condition	Rationale
Stationary Phase	C18, C8	Good retention for moderately non-polar chromene esters.
Mobile Phase	Acetonitrile/Water or Methanol/Water	Standard solvents for reversed-phase chromatography.
Additive	0.1% Formic Acid or Acetic Acid	Improves peak shape and provides protons for ESI+ detection.
Detection	UV (254 nm, 280 nm), MS	Chromene core is UV-active; MS provides mass information and high sensitivity.

Table 2. Typical RP-HPLC/UPLC conditions for chromene ester analysis.

## Chiral Separations (Enantioselective HPLC)

The separation of enantiomers is achieved by using a Chiral Stationary Phase (CSP) that interacts diastereomerically with the two enantiomers, leading to different retention times. Polysaccharide-based CSPs are the most widely used for this purpose.[3][12]

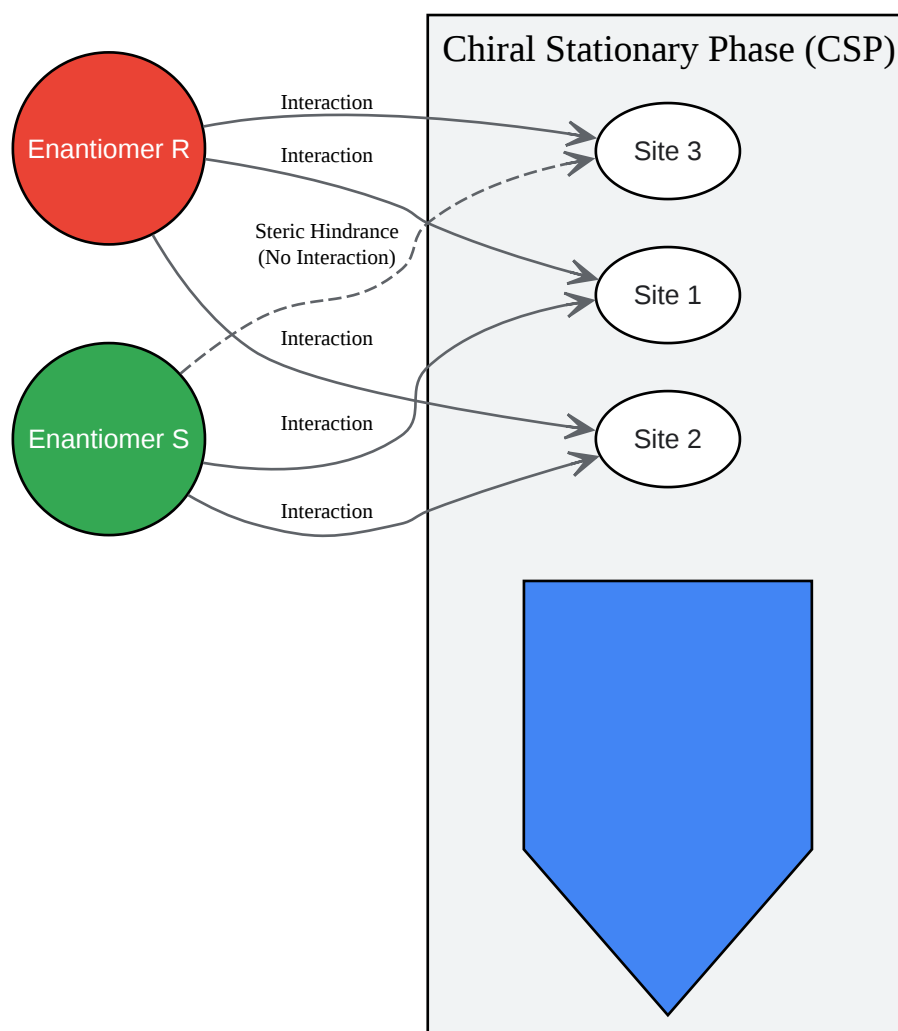

Enantiomer R (3-point interaction) is more strongly retained.  
Enantiomer S (2-point interaction) elutes faster.

[Click to download full resolution via product page](#)

Caption: The three-point interaction model for chiral recognition on a CSP.

## Protocol 3: Enantioselective Separation using a Polysaccharide-Based CSP

This protocol is based on successful methods for separating chiral chromenes like cannabichromene.[12]

- Causality: Polysaccharide CSPs (e.g., cellulose or amylose derivatives coated on silica) create chiral grooves and cavities. Separation occurs based on how well each enantiomer

fits into these cavities and interacts via hydrogen bonds, dipole-dipole, and  $\pi$ - $\pi$  interactions. Normal-phase conditions with non-polar mobile phases are typically used.

- Instrumentation: HPLC or UPLC system with UV detector.
- Chromatographic Conditions:
  - Column: A polysaccharide-based chiral column (e.g., CHIRALPAK® IK, Daicel OD-H).[12][13]
  - Mobile Phase: A mixture of a non-polar solvent and an alcohol, e.g., Hexane:Isopropanol (90:10, v/v) or Hexane:Dichloromethane (80:20, v/v).[12][13]
  - Flow Rate: 1.0 mL/min for analytical columns.
  - Column Temperature: 25 °C (temperature can be adjusted to optimize selectivity).[3]
  - Detection: UV at a wavelength where the chromene core absorbs strongly (e.g., 228 nm).
- Method Optimization:
  - Screen different chiral columns (amylose vs. cellulose-based) as their selectivities can be very different.[3]
  - Vary the alcohol modifier (isopropanol, ethanol) and its percentage in the mobile phase to fine-tune retention and resolution.

Parameter	Value (Cannabichromene on IK)[12]	Value (Cannabicyclol on IK) [12]
Retention Time (Enan 1)	5.23 min	7.91 min
Retention Time (Enan 2)	6.01 min	11.21 min
Selectivity ( $\alpha$ )	1.17	1.48
Resolution (Rs)	2.56	4.89

Table 3. Example performance of a chiral separation on a CHIRALPAK® IK column with a Hexane-Dichloromethane mobile phase.[12]

## Advanced & Green Chromatography: Supercritical Fluid Chromatography (SFC)

SFC is a powerful technique that bridges the gap between gas and liquid chromatography. It uses a supercritical fluid, most commonly carbon dioxide (CO<sub>2</sub>), as the primary mobile phase. [14][15] For the separation of chromene esters, particularly at the preparative scale, SFC offers significant advantages, including faster separations, reduced organic solvent consumption, and lower costs, making it a "green" alternative to normal-phase HPLC.[15][16]

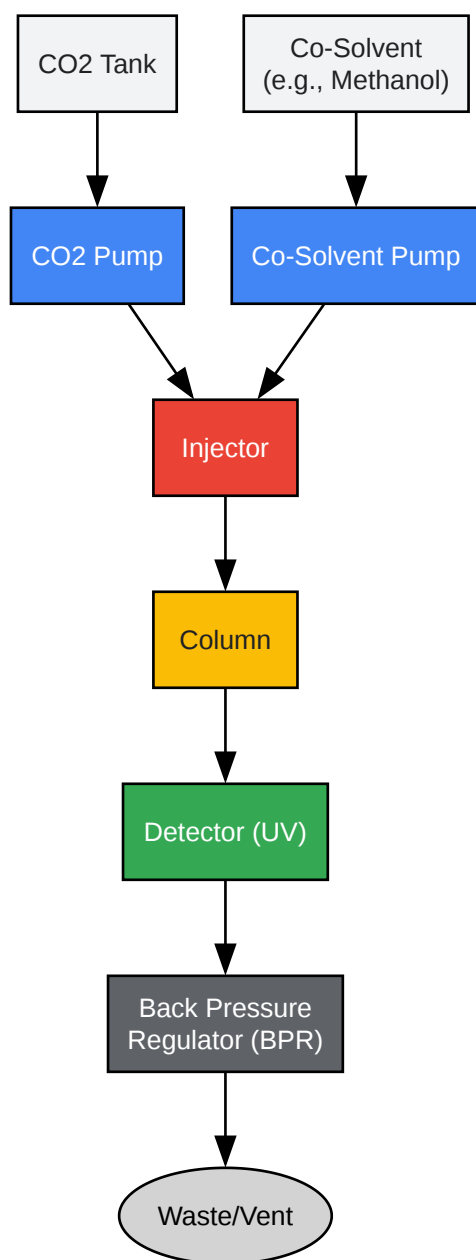

[Click to download full resolution via product page](#)

### Need Custom Synthesis?

BenchChem offers custom synthesis for rare earth carbides and specific isotopic labeling.

Email: [info@benchchem.com](mailto:info@benchchem.com) or [Request Quote Online](#).

## Sources

- 1. Enantiomeric separation of isochromene derivatives by high-performance liquid chromatography using cyclodextrin based stationary phases and principal component analysis of the separation data. | Sigma-Aldrich [[sigmaaldrich.com](https://sigmaaldrich.com)]
- 2. Enantiomeric chromene derivatives with anticancer effects from *Mallotus apelta* - PubMed [[pubmed.ncbi.nlm.nih.gov](https://pubmed.ncbi.nlm.nih.gov)]
- 3. [chromatographyonline.com](https://chromatographyonline.com) [[chromatographyonline.com](https://chromatographyonline.com)]
- 4. [biotage.com](https://biotage.com) [[biotage.com](https://biotage.com)]
- 5. [kinglab.chemistry.wfu.edu](https://kinglab.chemistry.wfu.edu) [[kinglab.chemistry.wfu.edu](https://kinglab.chemistry.wfu.edu)]
- 6. Purification [[chem.rochester.edu](https://chem.rochester.edu)]
- 7. [pdf.benchchem.com](https://pdf.benchchem.com) [[pdf.benchchem.com](https://pdf.benchchem.com)]
- 8. [biotage.com](https://biotage.com) [[biotage.com](https://biotage.com)]
- 9. [researchgate.net](https://researchgate.net) [[researchgate.net](https://researchgate.net)]
- 10. A validated UPLC-MS/MS method for pharmacokinetic study of inflachromene, a novel microglia inhibitor - PubMed [[pubmed.ncbi.nlm.nih.gov](https://pubmed.ncbi.nlm.nih.gov)]
- 11. Ultra-performance liquid chromatography-tandem mass spectrometry for the analysis of heterocyclic amines in food - PubMed [[pubmed.ncbi.nlm.nih.gov](https://pubmed.ncbi.nlm.nih.gov)]
- 12. [mdpi.com](https://mdpi.com) [[mdpi.com](https://mdpi.com)]
- 13. [researchgate.net](https://researchgate.net) [[researchgate.net](https://researchgate.net)]
- 14. What is Supercritical Fluid Chromatography (SFC) Chromatography? | Teledyne LABS [[teledynelabs.com](https://teledynelabs.com)]
- 15. Supercritical Fluid Chromatography (SFC) Columns | Phenomenex [[phenomenex.com](https://phenomenex.com)]
- 16. [ujps.twistingmemoirs.com](https://ujps.twistingmemoirs.com) [[ujps.twistingmemoirs.com](https://ujps.twistingmemoirs.com)]
- To cite this document: BenchChem. [Application Note: A Comprehensive Guide to the Chromatographic Separation of Chromene Esters]. BenchChem, [2026]. [Online PDF]. Available at: [<https://www.benchchem.com/product/b1501960/docs#application-note-a-comprehensive-guide-to-the-chromatographic-separation-of-chromene-esters>]

---

### Disclaimer & Data Validity:

The information provided in this document is for Research Use Only (RUO) and is strictly not intended for diagnostic or therapeutic procedures. While BenchChem strives to provide

accurate protocols, we make no warranties, express or implied, regarding the fitness of this product for every specific experimental setup.

**Technical Support:** The protocols provided are for reference purposes. Unsure if this reagent suits your experiment?

**Need Industrial/Bulk Grade?** [Request Custom Synthesis Quote](#)

## BenchChem

Our mission is to be the trusted global source of essential and advanced chemicals, empowering scientists and researchers to drive progress in science and industry.

### Contact

Address: 3281 E Guasti Rd

Ontario, CA 91761, United States

Phone: (601) 213-4426

Email: [info@benchchem.com](mailto:info@benchchem.com)

[Contact our Ph.D. Support Team for a compatibility check](#)