

Technical Support Center: 3-(2-Ethoxyethoxy)benzotrile Stability & Storage

Author: BenchChem Technical Support Team. **Date:** May 2026

Compound of Interest

Compound Name: 3-(2-Ethoxyethoxy)benzotrile

CAS No.: 1095085-73-6

Cat. No.: B1499002

[Get Quote](#)

Introduction: The Dual-Stability Paradox

As researchers, we often treat benzotriles as robust intermediates. However, **3-(2-Ethoxyethoxy)benzotrile** presents a specific "dual-threat" stability profile due to its hybrid structure. It combines a relatively stable aromatic nitrile with a labile glycol ether side chain.

This guide addresses the specific degradation pathways that occur when these two functionalities interact during long-term storage. The presence of the ethoxyethoxy tail introduces hygroscopicity and susceptibility to autoxidation, which can compromise the integrity of the nitrile group and introduce safety hazards.

Module 1: Critical Degradation Pathways

Understanding why the compound degrades is the first step to prevention. There are two primary mechanisms at play:

Ether Autoxidation (The Safety Hazard)

The glycol ether tail (

) is the weak link. The methylene protons adjacent to the ether oxygen are susceptible to radical abstraction by atmospheric oxygen. This leads to the formation of hydroperoxides, which can concentrate during distillation or evaporation, posing an explosion risk.

Moisture-Driven Hydrolysis (The Purity Hazard)

The glycol ether chain is hygroscopic. It pulls atmospheric moisture into the sample. Once water is present, the nitrile group (

) can undergo slow hydrolysis, catalyzed by trace acidic impurities or simply by prolonged exposure, converting first to the amide and eventually to the carboxylic acid.

Visualizing the Degradation Cycle

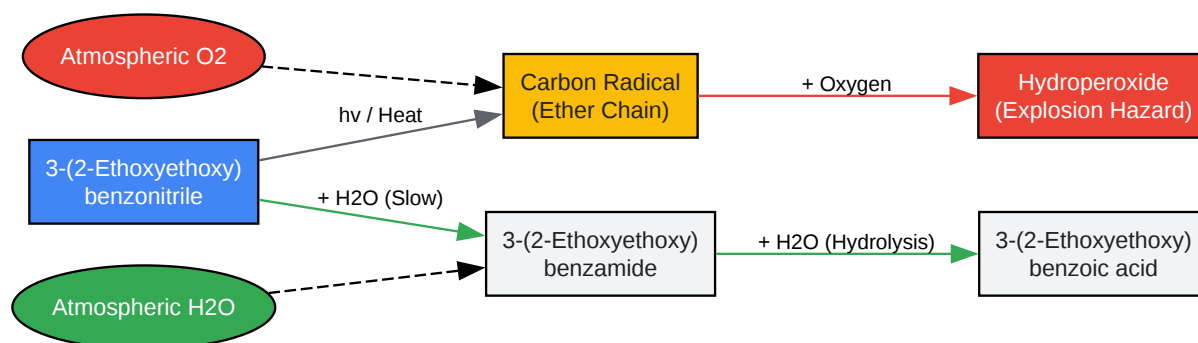

[Click to download full resolution via product page](#)

Figure 1: Mechanistic pathways showing parallel degradation risks: oxidative instability of the ether tail and hydrolytic instability of the nitrile head.

Module 2: Troubleshooting Guide (Q&A)

This section addresses specific observations you may encounter in the lab.

Q1: My liquid has turned from colorless to yellow/amber. Is it still usable?

Diagnosis: Oxidative Degradation. Yellowing in aryl ethers often indicates the formation of quinone-like impurities or N-oxides (if trace amine impurities were present). In this specific

molecule, it suggests the autoxidation of the ether chain has initiated, potentially generating trace aldehydes or cross-linked polymers.

- Action: Check purity by HPLC. If purity is >98%, the color is likely due to trace chromophores (<0.1%) and may be removed by a short silica plug.
- Critical Safety Check: Test for peroxides immediately. The yellowing implies oxygen exposure, meaning peroxides may be present.

Q2: I see a new peak in the NMR around 6.0–8.0 ppm (broad singlets) or a shift in the carbonyl region.

Diagnosis: Nitrile Hydrolysis. The nitrile carbon typically appears at ~118 ppm in

NMR. If you see a new signal at ~170 ppm, you have formed the amide. In

NMR, two broad singlets (exchangeable with

) indicate the

protons of the primary amide.

- Cause: The sample absorbed water due to the hygroscopic ether chain.
- Remediation: If the amide content is low (<5%), you can repurify via column chromatography (the amide is significantly more polar than the nitrile).

Q3: There is a white precipitate at the bottom of the bottle.

Diagnosis: Advanced Hydrolysis or Polymerization. 3-(2-Ethoxyethoxy)benzamide (the hydrolysis product) is a solid with a higher melting point than the nitrile liquid. It is likely precipitating out of the solution.

- Action: Filter the solid and analyze it. If it is the amide, the supernatant liquid might still be salvageable after drying and redistillation.

Module 3: Storage & Handling Protocols

To maintain stability, you must disrupt the Oxygen-Moisture-Light triangle.

Protocol A: The "Golden Standard" Storage System

Follow this for storage >1 month.

- Container: Amber glass vial (borosilicate). Never store in clear glass or plastic.
- Atmosphere: Purge headspace with Argon (preferred over Nitrogen due to higher density).
- Temperature: Store at +2°C to +8°C. Freezing is acceptable but may cause phase separation of impurities; ensure full thawing and vortexing before use.
- Seal: Parafilm is insufficient. Use a Teflon-lined screw cap and wrap the junction with electrical tape or a secondary seal.

Protocol B: Peroxide Testing & Removal

Mandatory before heating or distilling stored material.

Test Method	Procedure	Observation	Action
Quantofix® Strips	Dip strip into liquid for 1 sec.	Blue color indicates peroxides.	STOP. Do not distill.
KI / Starch	Add 100 µL sample to 1 mL glacial acetic acid + 100 mg KI.	Yellow/Brown color appears.[1][2]	STOP. Treat sample.

Peroxide Removal (if <1% detected):

- Pass the liquid through a column of activated basic alumina. The alumina adsorbs the hydroperoxides.
- Retest the eluate to confirm peroxide removal.

Protocol C: Re-Drying (Moisture Removal)

If hydrolysis is a concern.

- Dissolve compound in dry Dichloromethane (DCM).
- Dry over activated Molecular Sieves (3Å) for 4 hours. Avoid acidic drying agents (like or Silica) if the compound is already degrading, as acidity accelerates nitrile hydrolysis.
- Filter and concentrate under reduced pressure.

Module 4: Quality Control Decision Matrix

Use this flowchart to determine if your batch is safe for experimentation.

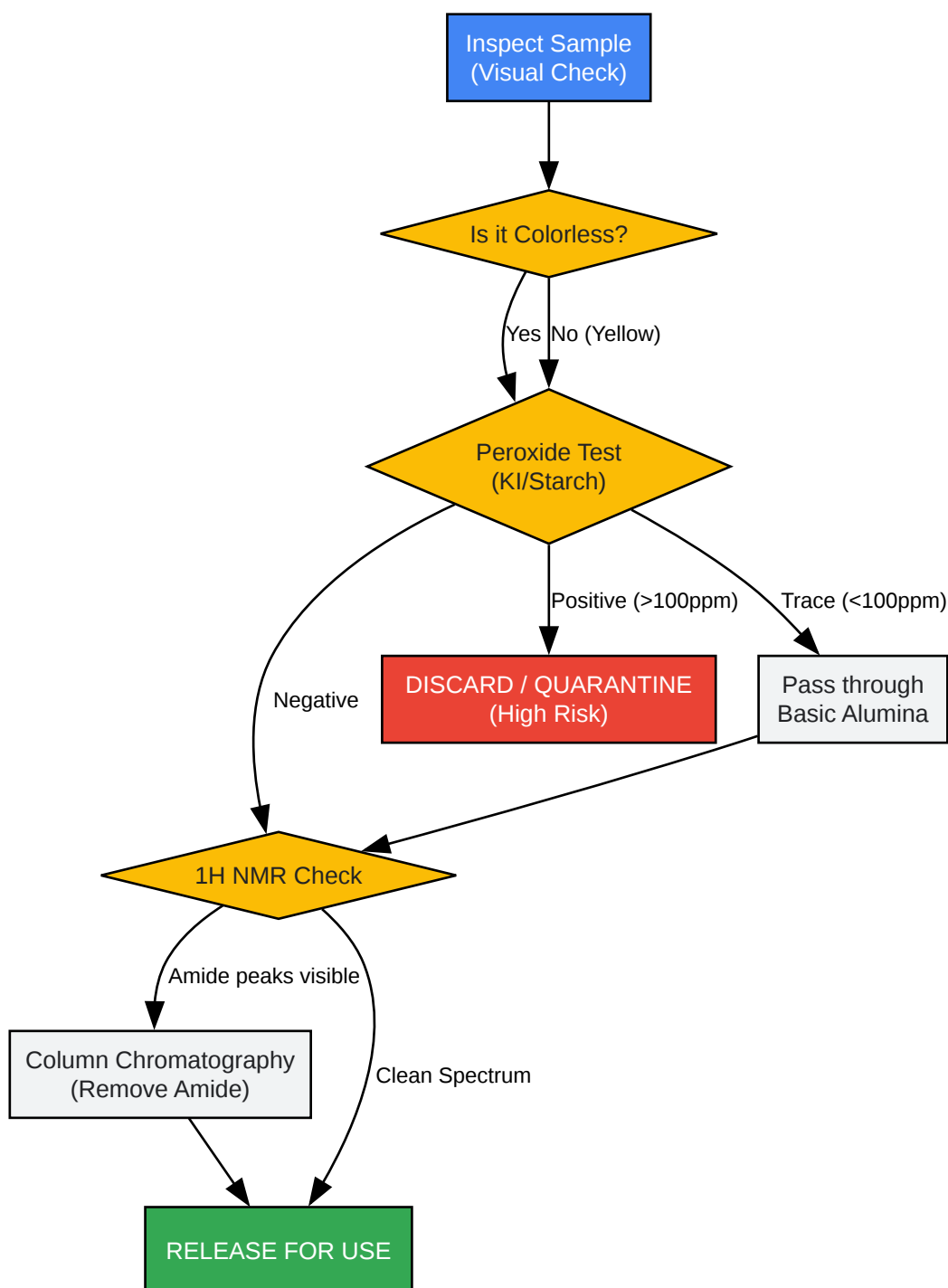

[Click to download full resolution via product page](#)

Figure 2: Decision matrix for evaluating stored **3-(2-Ethoxyethoxy)benzotrile** batches.

References

- Nitrile Hydrolysis Mechanisms

- Pearson Education. Hydrolysis of Nitriles. (Accessed 2026).[2] The mechanism involves nucleophilic attack by water on the cyano carbon, accelerated by pH extremes.
- Ether Autoxidation & Peroxide Safety
 - LibreTexts Chemistry. 15.6: Autoxidation of Ethers. (2020). Details the radical mechanism where oxygen attacks the alpha-carbon of the ether linkage.
- Glycol Ether Atmospheric Chemistry
 - Li, Z., et al. Atmospheric Photo-Oxidation of 2-Ethoxyethanol: Autoxidation Chemistry of Glycol Ethers. ACS Earth and Space Chemistry.[3] (2023).[4][5][6] Provides in-depth analysis of the instability of the ethoxyethoxy chain.
- General Benzonitrile Safety Data
 - National Oceanic and Atmospheric Administration (NOAA). Benzonitrile Chemical Datasheet. CAMEO Chemicals.[1][7]

Need Custom Synthesis?

BenchChem offers custom synthesis for rare earth carbides and specific isotopic labeling.

Email: info@benchchem.com or [Request Quote Online](#).

Sources

- [1. cdn.chemservice.com](https://cdn.chemservice.com) [cdn.chemservice.com]
- [2. youtube.com](https://youtube.com) [youtube.com]
- [3. chemrxiv.org](https://chemrxiv.org) [chemrxiv.org]
- [4. 2-\(3-Ethoxyphenoxy\)benzonitrile | C₁₅H₁₃NO₂ | CID 62336711 - PubChem](https://pubchem.ncbi.nlm.nih.gov/compound/2-(3-ethoxyphenoxy)benzonitrile) [pubchem.ncbi.nlm.nih.gov]
- [5. 3-\(2-Oxoethyl\)benzonitrile | C₉H₇NO | CID 17872140 - PubChem](https://pubchem.ncbi.nlm.nih.gov/compound/3-(2-oxoethyl)benzonitrile) [pubchem.ncbi.nlm.nih.gov]
- [6. Glycol Ether Toxicology - StatPearls - NCBI Bookshelf](https://www.ncbi.nlm.nih.gov/books/NBK55709/) [ncbi.nlm.nih.gov]
- [7. cameochemicals.noaa.gov](https://cameochemicals.noaa.gov) [cameochemicals.noaa.gov]

- To cite this document: BenchChem. [Technical Support Center: 3-(2-Ethoxyethoxy)benzonitrile Stability & Storage]. BenchChem, [2026]. [Online PDF]. Available at: [<https://www.benchchem.com/product/b1499002/docs#technical-support-center-3-2-ethoxyethoxy-benzonitrile-stability-storage>]

Disclaimer & Data Validity:

The information provided in this document is for Research Use Only (RUO) and is strictly not intended for diagnostic or therapeutic procedures. While BenchChem strives to provide accurate protocols, we make no warranties, express or implied, regarding the fitness of this product for every specific experimental setup.

Technical Support: The protocols provided are for reference purposes. Unsure if this reagent suits your experiment?

Need Industrial/Bulk Grade? [Request Custom Synthesis Quote](#)

BenchChem

Our mission is to be the trusted global source of essential and advanced chemicals, empowering scientists and researchers to drive progress in science and industry.

Contact

Address: 3281 E Guasti Rd
Ontario, CA 91761, United States
Phone: (601) 213-4426
Email: info@benchchem.com

[Contact our Ph.D. Support Team for a compatibility check](#)