

Technical Support Center: Optimizing N-Benylation of Piperidines

Author: BenchChem Technical Support Team. **Date:** May 2026

Compound of Interest

Compound Name:	Benzyl 4-(benzylamino)piperidine-1-carboxylate
CAS No.:	206274-42-2
Cat. No.:	B1498265

[Get Quote](#)

Welcome to the Technical Support Center. This guide, curated by our Senior Application Scientists, provides in-depth troubleshooting advice and answers to frequently asked questions regarding the N-benylation of piperidines. Our goal is to empower researchers, scientists, and drug development professionals to overcome common challenges and achieve optimal results in their synthetic endeavors.

Guiding Principles: The Chemistry of N-Benylation

The N-benylation of a piperidine is a nucleophilic substitution reaction, specifically an SN2 reaction. The piperidine nitrogen, with its lone pair of electrons, acts as the nucleophile, attacking the electrophilic benzylic carbon of the benzylation agent (e.g., benzyl bromide). This forms a new carbon-nitrogen bond.

A critical aspect of this reaction is the concurrent formation of an acid byproduct (e.g., HBr). This acid can protonate the starting piperidine, rendering it non-nucleophilic and halting the reaction.^{[1][2]} Therefore, the inclusion of a base to neutralize this acid is essential for the reaction to proceed to completion.^{[2][3]}

The product, an N-benzylpiperidine, is a tertiary amine. While generally less nucleophilic than the starting secondary amine, it can still react with the benzylating agent, especially under forcing conditions or with an excess of the alkylating agent, to form an over-alkylated quaternary ammonium salt.^{[1][4][5]} Understanding these core principles is the first step to effective troubleshooting.

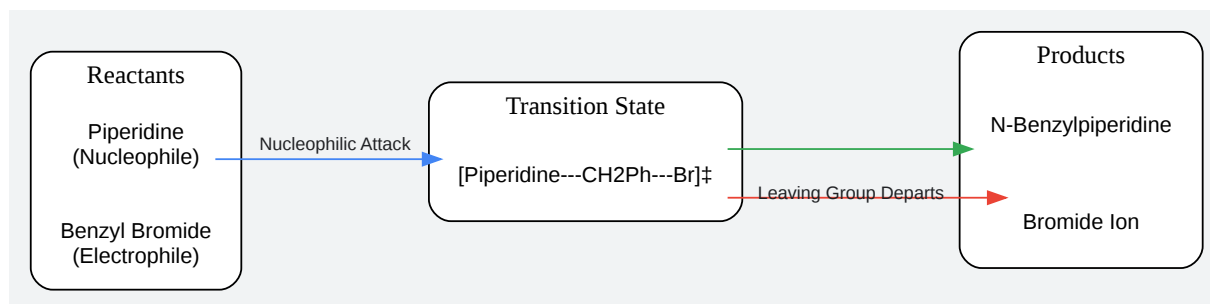

[Click to download full resolution via product page](#)

Caption: The SN2 mechanism for N-benylation of piperidine.

Troubleshooting Guide: Common Issues and Solutions

This section addresses specific problems you may encounter during the N-benylation of piperidines in a question-and-answer format.

Question 1: My reaction is very slow or appears to have stalled. What's the cause?

Answer: A stalled or sluggish reaction is one of the most common issues and can usually be attributed to one of four factors:

- **Insufficient Basicity:** As the reaction proceeds, the generated hydrohalic acid (HBr or HCl) protonates the piperidine starting material. A protonated amine is no longer a nucleophile. If your base is too weak or is not present in sufficient quantity, the reaction will slow down and eventually stop as the concentration of free piperidine decreases.^{[1][2]}

- Solution: Ensure you are using at least one equivalent of a suitable base. Inorganic bases like potassium carbonate (K_2CO_3) or cesium carbonate (Cs_2CO_3) are often effective.^{[3][6]} For more sensitive substrates, non-nucleophilic organic bases like N,N-diisopropylethylamine (DIPEA) or triethylamine (Et_3N) can be used.^{[1][3]}
- Poor Leaving Group: The reactivity of the benzylating agent is critical. The order of reactivity for benzyl halides is Benzyl Iodide > Benzyl Bromide > Benzyl Chloride.
 - Solution: If you are using benzyl chloride and observing slow kinetics, switching to benzyl bromide will significantly increase the reaction rate.
- Inappropriate Solvent: The solvent plays a crucial role in an SN_2 reaction. Polar aprotic solvents are ideal as they can solvate the cation of the base without strongly solvating the nucleophilic amine, thus not impeding its reactivity.
 - Solution: Switch to a polar aprotic solvent like acetonitrile (MeCN) or N,N-dimethylformamide (DMF).^[1] These are generally superior to less polar solvents like THF or toluene for this transformation.^[7]
- Steric Hindrance: If your piperidine ring or benzylating agent has bulky substituents near the reacting centers, this can physically block the nucleophilic attack.
 - Solution: Increase the reaction temperature to provide more kinetic energy to overcome the steric barrier. If the problem persists, a different synthetic route may be necessary.^[1]

Question 2: I'm getting a significant amount of an insoluble white solid, and my desired product yield is low. What is this byproduct?

Answer: The white solid is likely a quaternary ammonium salt, the product of over-alkylation.^[1] This happens when the N-benzylpiperidine product, which is a tertiary amine, acts as a nucleophile and reacts with another molecule of the benzylating agent. This is a common side reaction, especially with highly reactive benzylating agents.^{[1][4]}

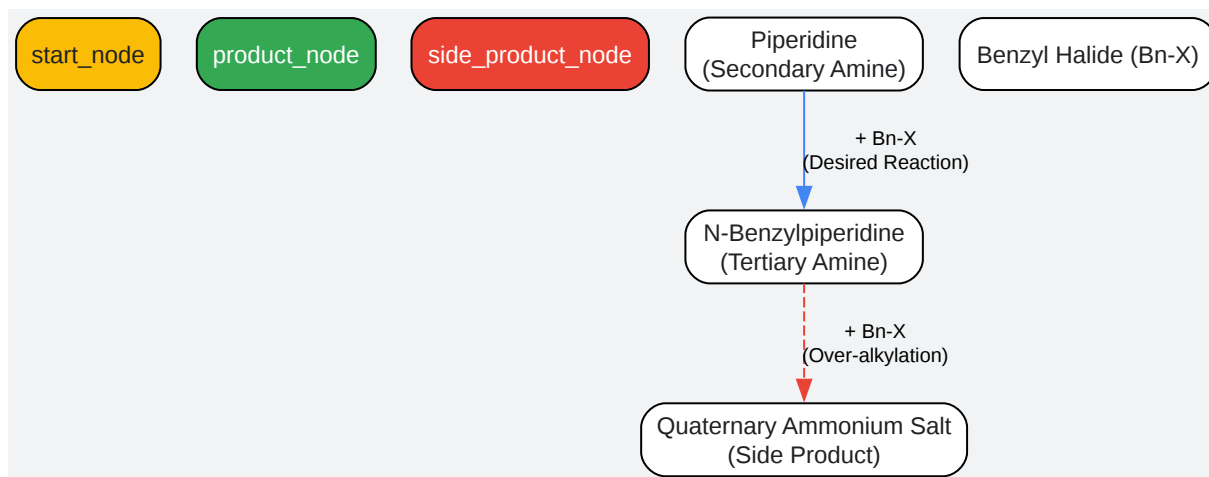

[Click to download full resolution via product page](#)

Caption: Reaction pathway showing desired product and over-alkylation.

Here are several strategies to minimize the formation of the quaternary salt:

- **Control Stoichiometry:** Use a slight excess of the piperidine (e.g., 1.1 to 1.2 equivalents) relative to the benzylating agent. This ensures the benzylating agent is consumed before it can significantly react with the product.^[1]
- **Slow Addition:** Add the benzylating agent slowly to the reaction mixture, using a syringe pump if possible.^{[1][3]} This keeps the instantaneous concentration of the benzylating agent low, favoring the reaction with the more nucleophilic starting piperidine over the tertiary amine product.
- **Lower the Temperature:** Running the reaction at a lower temperature (e.g., room temperature instead of reflux) can reduce the rate of the second alkylation more than the first, thus improving selectivity.^[1]

Question 3: My purification is difficult. The product seems to be contaminated with the base or is difficult to separate from starting material.

Answer: Purification challenges often arise from the choice of work-up procedure. A standard and effective method is an acidic-basic aqueous work-up.

Recommended Purification Protocol:

- **Quench and Dilute:** Once the reaction is complete (monitored by TLC or LCMS), cool the mixture to room temperature. Dilute with an organic solvent like ethyl acetate or diethyl ether.
- **Acidic Wash:** Wash the organic layer with a dilute acid solution (e.g., 1M HCl). Your N-benzylpiperidine product and any unreacted piperidine will be protonated and move into the aqueous layer. The non-basic impurities and byproducts will remain in the organic layer, which can be discarded.
- **Basify and Extract:** Cool the acidic aqueous layer in an ice bath and add a strong base (e.g., 10% NaOH solution) until it is strongly basic (pH > 12). This deprotonates your amine product, making it soluble in organic solvents again.^[3]
- **Back-Extraction:** Extract the now-basic aqueous layer several times with fresh portions of an organic solvent (e.g., ethyl acetate or dichloromethane).
- **Dry and Concentrate:** Combine the organic extracts, dry them over an anhydrous salt (e.g., Na₂SO₄ or MgSO₄), filter, and concentrate under reduced pressure to yield your purified N-benzylpiperidine.
- **Final Purification:** If necessary, further purification can be achieved by flash column chromatography on silica gel or distillation.^[7]

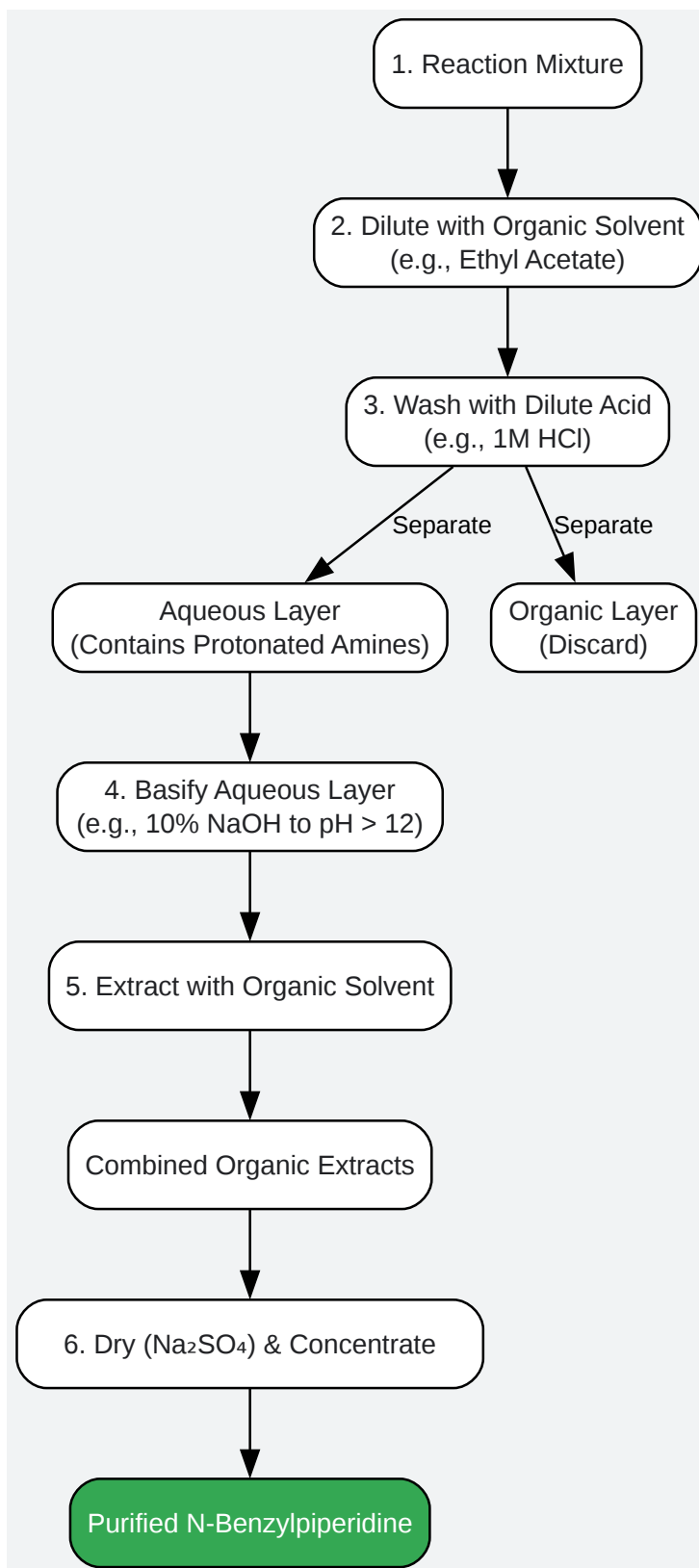

[Click to download full resolution via product page](#)

Caption: Workflow for a standard acid-base extraction purification.

Frequently Asked Questions (FAQs)

Q: Which benzylating agent is best: benzyl bromide or benzyl chloride? A: Benzyl bromide is more reactive than benzyl chloride due to bromide being a better leaving group. For most applications, benzyl bromide will give faster reaction times and allow for milder conditions. However, it is also more lachrymatory and may be more expensive. Benzyl chloride can be effective but may require higher temperatures or longer reaction times.

Q: Can I use an alcohol like benzyl alcohol instead of a halide? A: Yes, N-benylation using benzyl alcohol is a well-established "green chemistry" alternative.^[8] This method, often called a "hydrogen borrowing" or "hydrogen auto-transfer" reaction, typically requires a transition metal catalyst (e.g., based on Palladium, Ruthenium, or Nickel).^{[9][10]} The only byproduct is water, making it an atom-economical process. However, it requires catalyst screening and optimization and may not be suitable for all substrates.^[9]

Q: What is the best base for this reaction? A comparison would be helpful. A: The choice of base depends on your substrate's sensitivity and the desired reaction conditions.

Base	Type	pKa of Conjugate Acid	Common Solvents	Key Considerations
K ₂ CO ₃	Inorganic	~10.3	Acetonitrile, DMF	Inexpensive, effective, and easy to remove by filtration. A common first choice.[3]
Cs ₂ CO ₃	Inorganic	~10.3	Acetonitrile, DMF	More soluble than K ₂ CO ₃ , can sometimes lead to higher yields, especially in challenging cases.[6]
DIPEA	Organic (non-nucleophilic)	~10.7	DCM, Acetonitrile	Soluble in organic solvents, good for homogenous reactions. Its bulkiness prevents it from acting as a nucleophile.[3]
Et ₃ N	Organic (non-nucleophilic)	~10.7	DCM, Acetonitrile	Less sterically hindered than DIPEA and can sometimes lead to quaternary amine formation with the base itself if reactive alkylating agents are used.

Q: How do I know when my reaction is complete? A: The most reliable way to monitor the reaction is by using Thin Layer Chromatography (TLC) or Liquid Chromatography-Mass Spectrometry (LCMS).

- TLC: Spot the reaction mixture alongside your starting piperidine. The product, being more nonpolar, should have a higher R_f value. The disappearance of the starting material spot indicates the reaction is complete.
- LCMS: This provides a more definitive analysis, showing the mass of the starting material, product, and any byproducts, allowing for precise monitoring of the reaction's progress.

References

- Procedure for N-alkylation of Piperidine? (2017). ResearchGate. [[Link](#)]
- Kaur, R., et al. (2025). Efficient and selective N-benylation of amines using Pd-doped La-BDC MOF. Materials Advances. [[Link](#)]
- Martinez, R., et al. (2017). Cs₂CO₃-Promoted Direct N-Alkylation: Highly Chemoselective Synthesis of N-Alkylated Benzylamines and Anilines. ResearchGate. [[Link](#)]
- Fodor, Z., et al. (2019). Primary Benzylamines by Efficient N-Alkylation of Benzyl Alcohols Using Commercial Ni Catalysts and Easy-to-Handle Ammonia Sources. ACS Sustainable Chemistry & Engineering. [[Link](#)]
- Synthesis of secondary and tertiary amines. (n.d.). Organic Chemistry Portal. [[Link](#)]
- Sommer, H. Z., et al. (1967). ALKYLATION OF AMINES: A NEW METHOD FOR THE SYNTHESIS OF QUATERNARY AMMONIUM COMPOUNDS FROM PRIMARY AND SECONDARY AMINES. DTIC. [[Link](#)]
- Kaur, R., et al. (2025). Efficient and selective N-benylation of amines using Pd-doped La-BDC MOF. Materials Advances (RSC Publishing). [[Link](#)]
- Ashenhurst, J. (2017). Alkylation of Amines (Sucks!). Master Organic Chemistry. [[Link](#)]
- Synthesis of benzylic amines. (n.d.). Organic Chemistry Portal. [[Link](#)]

- Mechanism of Amine Alkylation. (n.d.). University of Calgary. [[Link](#)]
- LibreTexts Chemistry. (2019). 23.16: Synthesis of Amines by Alkylation. [[Link](#)]

Need Custom Synthesis?

BenchChem offers custom synthesis for rare earth carbides and specific isotopic labeling.

Email: info@benchchem.com or [Request Quote Online](#).

Sources

- 1. [benchchem.com](https://www.benchchem.com) [[benchchem.com](https://www.benchchem.com)]
- 2. apps.dtic.mil [apps.dtic.mil]
- 3. [researchgate.net](https://www.researchgate.net) [[researchgate.net](https://www.researchgate.net)]
- 4. [masterorganicchemistry.com](https://www.masterorganicchemistry.com) [[masterorganicchemistry.com](https://www.masterorganicchemistry.com)]
- 5. chem.libretexts.org [chem.libretexts.org]
- 6. [researchgate.net](https://www.researchgate.net) [[researchgate.net](https://www.researchgate.net)]
- 7. pubs.acs.org [pubs.acs.org]
- 8. Efficient and selective N-benylation of amines using Pd-doped La-BDC MOF - Materials Advances (RSC Publishing) DOI:10.1039/D5MA00372E [pubs.rsc.org]
- 9. Efficient and selective N-benylation of amines using Pd-doped La-BDC MOF - Materials Advances (RSC Publishing) [pubs.rsc.org]
- 10. Benzylic amine synthesis by amination (arylation) [[organic-chemistry.org](https://www.organic-chemistry.org)]
- To cite this document: BenchChem. [Technical Support Center: Optimizing N-Benylation of Piperidines]. BenchChem, [2026]. [Online PDF]. Available at: [<https://www.benchchem.com/product/b1498265/docs#technical-support-center-optimizing-n-benylation-of-piperidines>]

Disclaimer & Data Validity:

The information provided in this document is for Research Use Only (RUO) and is strictly not intended for diagnostic or therapeutic procedures. While BenchChem strives to provide

accurate protocols, we make no warranties, express or implied, regarding the fitness of this product for every specific experimental setup.

Technical Support: The protocols provided are for reference purposes. Unsure if this reagent suits your experiment?

Need Industrial/Bulk Grade? [Request Custom Synthesis Quote](#)

BenchChem

Our mission is to be the trusted global source of essential and advanced chemicals, empowering scientists and researchers to drive progress in science and industry.

Contact

Address: 3281 E Guasti Rd

Ontario, CA 91761, United States

Phone: (601) 213-4426

Email: info@benchchem.com

[Contact our Ph.D. Support Team for a compatibility check](#)