

Comparative Guide: PSB-11 vs. MRS1220 Potency in Human Cell Lines

Author: BenchChem Technical Support Team. **Date:** May 2026

Compound of Interest

Compound Name: *Psb 11 hydrochloride*

CAS No.: *444717-56-0*

Cat. No.: *B1497081*

[Get Quote](#)

Executive Summary

PSB-11 and MRS1220 represent two of the most potent and selective antagonists for the human A3 Adenosine Receptor (hA3AR) available to researchers today. While both compounds exhibit nanomolar affinity and high selectivity for the human isoform over A1 and A2A subtypes, they differ significantly in their structural class, absolute potency, and experimental utility.

- MRS1220 is the potency leader (nM), making it the "gold standard" for blocking hA3AR in functional assays (e.g., cancer cell apoptosis or inflammatory cytokine release).
- PSB-11 (nM) serves a dual role: it is a highly potent antagonist and, in its tritiated form ($[^3\text{H}]$ PSB-11), acts as a superior radioligand for binding kinetics studies due to its favorable dissociation profile.

Critical Note on Species Selectivity: Both compounds are species-specific. They are highly potent in human cell lines but display negligible affinity (

) for rat or mouse A3 receptors. For rodent models, alternative antagonists (e.g., MRS1523) must be used.[1]

Mechanistic Profile & Signaling Pathway[2][3][4]

Both PSB-11 and MRS1220 function as orthosteric antagonists (or inverse agonists) of the A3 Adenosine Receptor, a G-protein coupled receptor (GPCR).

Mechanism of Action[2][4][5][6][7]

- **Ligand Binding:** The antagonist binds to the extracellular orthosteric site of the hA3AR, preventing the binding of endogenous adenosine or synthetic agonists (e.g., CI-IB-MECA).
- **G-Protein Blockade:** Under agonist stimulation, hA3AR couples to Gi/o proteins. This normally inhibits Adenylyl Cyclase (AC), reducing cAMP levels, and activates downstream kinases (ERK1/2, Akt).
- **Antagonist Effect:** MRS1220 or PSB-11 prevents this Gi-coupling.[2] In cells treated with Forskolin (which artificially raises cAMP), these antagonists reverse the agonist-induced drop in cAMP.

A3AR Signaling Pathway Diagram

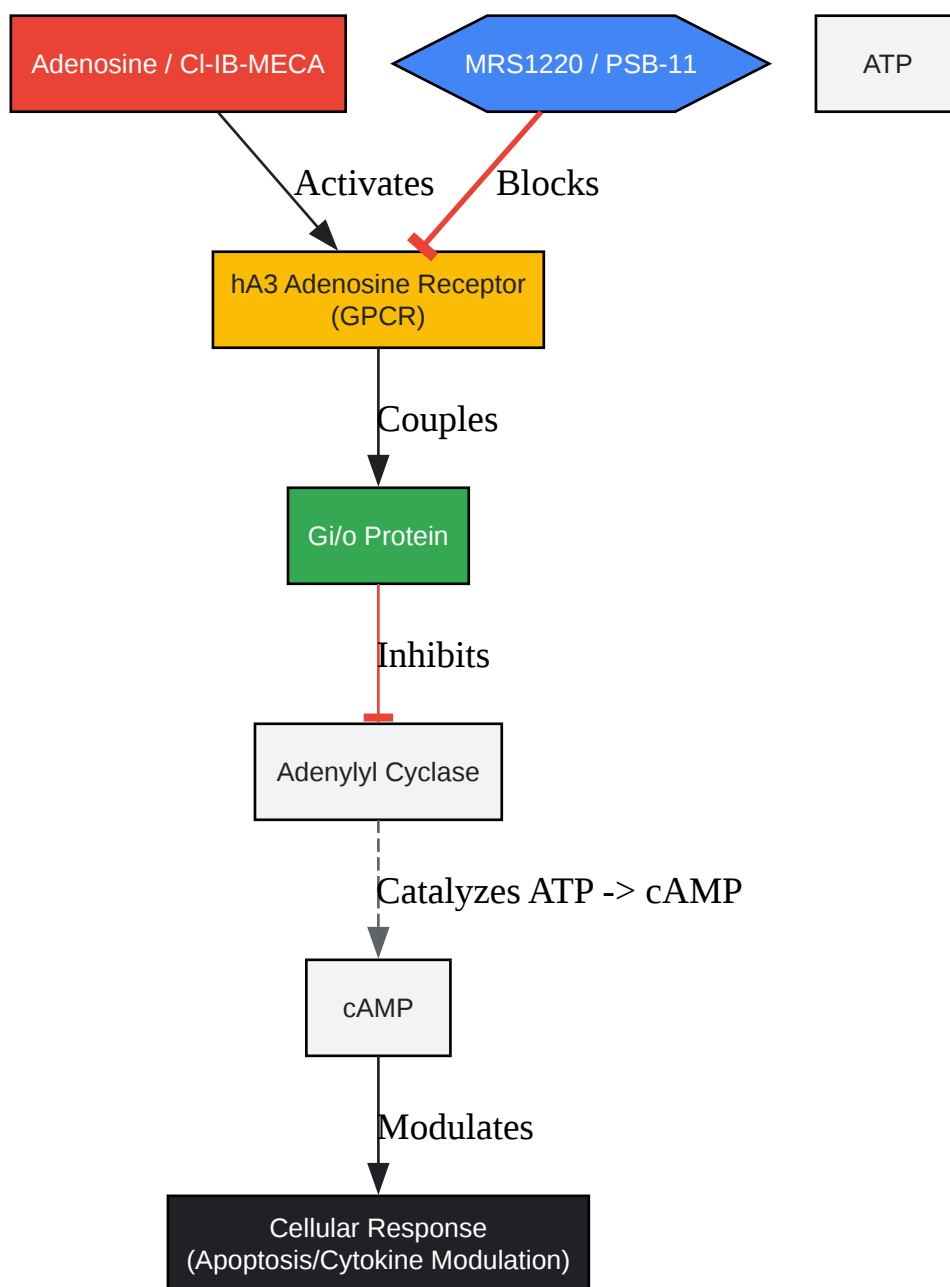

[Click to download full resolution via product page](#)

Figure 1: Mechanism of A3AR antagonism. MRS1220/PSB-11 prevent Gi-mediated inhibition of Adenylyl Cyclase.

Comparative Potency Analysis

The following data aggregates binding affinity (

) and functional potency (

) from human cell lines (CHO-hA3, HEK293, and HL-60).

Table 1: Pharmacological Profile Comparison

Feature	MRS1220	PSB-11
Chemical Class	Triazoloquinazoline	Imidazopurine (Tricyclic Xanthine)
Binding Affinity ()	0.59 – 0.65 nM [1, 2]	2.3 – 4.6 nM [3, 4]
Functional (cAMP)	~1.7 nM (Schild Analysis)	~5.0 – 10.0 nM
hA3 vs. hA1 Selectivity	> 500-fold	> 1000-fold
hA3 vs. hA2A Selectivity	> 80-fold	> 10,000-fold
Species Cross-Reactivity	Human only (Inactive in Rat/Mouse)	Human only (Inactive in Rat/Mouse)
Primary Application	Functional blockade (Potency)	Radioligand Binding / Structural Studies

Key Insight: Why Choose One Over the Other?

- Select MRS1220 if your primary goal is maximum suppression of A3AR signaling in a functional assay (e.g., tumor growth inhibition in glioblastoma lines). Its sub-nanomolar affinity ensures complete receptor occupancy at low concentrations, minimizing off-target risks.
- Select PSB-11 if you are performing competition binding assays. The tritiated form, [³H]PSB-11, has low non-specific binding and fast association/dissociation kinetics, making it superior to older radioligands like [¹²⁵I]AB-MECA for characterizing new ligands.

Experimental Protocols

To ensure data integrity (Trustworthiness), these protocols utilize self-validating controls (e.g., non-specific binding checks).

Protocol A: Radioligand Competition Binding (Membrane Prep)

Objective: Determine the

of a test compound using [³H]PSB-11 as the tracer.

- Cell Culture: Grow CHO cells stably expressing hA3AR. Harvest and homogenize in ice-cold Tris-HCl buffer (50 mM, pH 7.4).
- Membrane Preparation: Centrifuge homogenate at 40,000 x g for 20 min. Resuspend pellet in assay buffer (50 mM Tris-HCl, 10 mM MgCl₂, 1 mM EDTA).
- Incubation Setup:
 - Total Binding: Membranes (20-40 µg protein) + [³H]PSB-11 (1.0 nM).
 - Non-Specific Binding (NSB): Above + 10 µM R-PIA or NECA (saturating concentration).
 - Test Sample: Above + MRS1220 (range
to
M).
- Reaction: Incubate for 60 min at 25°C.
- Termination: Rapid filtration through GF/B filters using a cell harvester. Wash 3x with ice-cold buffer.
- Analysis: Measure radioactivity via liquid scintillation counting. Calculate
and convert to
using the Cheng-Prusoff equation.

Protocol B: Functional cAMP Accumulation Assay

Objective: Verify antagonist potency of MRS1220 against an agonist (CI-IB-MECA).

- Seeding: Plate hA3AR-expressing HEK293 cells (2,000 cells/well) in a 384-well plate.
- Pre-treatment: Incubate cells with MRS1220 (serial dilutions) for 15 min at 37°C.
- Stimulation: Add a mixture of Forskolin (10 μ M) and CI-IB-MECA (concentration, typically 10-30 nM).
 - Logic: Forskolin increases cAMP; Agonist (CI-IB-MECA) decreases it via Gi. Antagonist (MRS1220) should restore cAMP levels.
- Detection: Incubate 30 min. Lyse cells and detect cAMP using a TR-FRET kit (e.g., LANCE or HTRF).
- Validation: The signal should return to "Forskolin-only" levels as MRS1220 concentration increases.

Experimental Workflow Diagram

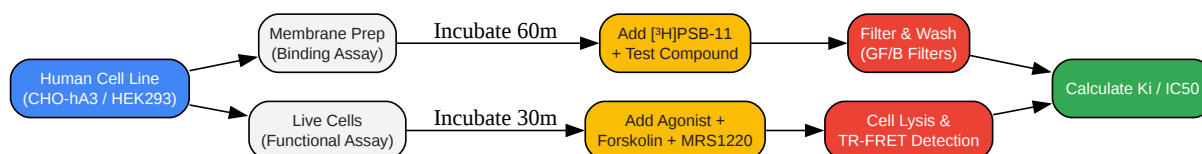

[Click to download full resolution via product page](#)

Figure 2: Parallel workflows for validating potency via Radioligand Binding (Top) and Functional cAMP Assay (Bottom).

References

- Jacobson, K. A., et al. (1997). Pharmacological characterization of novel A3 adenosine receptor-selective antagonists.[3]Neuropharmacology.

- Kim, Y. C., et al. (1996). Derivatives of the triazoloquinazoline adenosine antagonist (CGS 15943) having high affinity for the human A3 receptor. *Journal of Medicinal Chemistry*.
- Müller, C. E., et al. (2002). [4] [3H]8-Ethyl-4-methyl-2-phenyl-(8R)-4,5,7,8-tetrahydro-1H-imidazo[2,1-i]purin-5-one ([3H]PSB-11), a novel high-affinity antagonist radioligand for human A3 adenosine receptors. [4] *Bioorganic & Medicinal Chemistry Letters*.
- Gao, Z. G., et al. (2002). Allosteric modulation of the human A3 adenosine receptor by imidazoquinoline derivatives. *Molecular Pharmacology*.

Need Custom Synthesis?

BenchChem offers custom synthesis for rare earth carbides and specific isotopic labeling.

Email: info@benchchem.com or [Request Quote Online](#).

Sources

- [1. researchgate.net \[researchgate.net\]](https://www.researchgate.net)
- [2. pubs.acs.org \[pubs.acs.org\]](https://pubs.acs.org)
- [3. Pharmacological Characterization of Novel A3 Adenosine Receptor-selective Antagonists - PMC \[pmc.ncbi.nlm.nih.gov\]](https://pubmed.ncbi.nlm.nih.gov/)
- [4. medchemexpress.com \[medchemexpress.com\]](https://www.medchemexpress.com)
- To cite this document: BenchChem. [Comparative Guide: PSB-11 vs. MRS1220 Potency in Human Cell Lines]. BenchChem, [2026]. [Online PDF]. Available at: [\[https://www.benchchem.com/product/b1497081/docs#comparative-guide-psb-11-vs-mrs1220-potency-in-human-cell-lines\]](https://www.benchchem.com/product/b1497081/docs#comparative-guide-psb-11-vs-mrs1220-potency-in-human-cell-lines)

Disclaimer & Data Validity:

The information provided in this document is for Research Use Only (RUO) and is strictly not intended for diagnostic or therapeutic procedures. While BenchChem strives to provide accurate protocols, we make no warranties, express or implied, regarding the fitness of this product for every specific experimental setup.

Technical Support: The protocols provided are for reference purposes. Unsure if this reagent suits your experiment?

Need Industrial/Bulk Grade? [Request Custom Synthesis Quote](#)

BenchChem

Our mission is to be the trusted global source of essential and advanced chemicals, empowering scientists and researchers to drive progress in science and industry.

Contact

Address: 3281 E Guasti Rd
Ontario, CA 91761, United States
Phone: (601) 213-4426
Email: info@benchchem.com

[Contact our Ph.D. Support Team for a compatibility check](#)