

Aniline vs. Aliphatic Linkers in Drug Design: A Comparative Guide

Author: BenchChem Technical Support Team. **Date:** April 2026

Compound of Interest

Compound Name: 2-[3-(Boc-amino)propyloxy]aniline

Cat. No.: B1497819

[Get Quote](#)

In the intricate world of drug design, particularly in the development of targeted therapies like Antibody-Drug Conjugates (ADCs) and Proteolysis Targeting Chimeras (PROTACs), the linker connecting the targeting moiety to the payload is a critical determinant of therapeutic success. [1][2][3] The choice of linker profoundly influences a drug's stability, pharmacokinetic (PK) and pharmacodynamic (PD) profiles, and ultimately, its efficacy and safety. [1][4][5] This guide provides an in-depth comparative analysis of two major classes of linkers: aniline-based linkers and aliphatic linkers, offering insights into their respective advantages and disadvantages to aid researchers in making informed decisions for their drug design strategies.

The Pivotal Role of Linkers in Targeted Therapies

Linkers are more than just molecular bridges; they are dynamic components that must perform a delicate balancing act. An ideal linker should be sufficiently stable in systemic circulation to prevent premature payload release, which could lead to off-target toxicity and reduced efficacy. [1][4][6] Conversely, upon reaching the target site, the linker must be efficiently cleaved to release the active payload in its intended cellular compartment. [3][4][6] Key parameters to consider in linker design include its chemical nature, length, rigidity, and hydrophilicity, all of which must be optimized for a given application. [7][8]

Aniline Linkers: Leveraging Aromatic Properties for Controlled Release

Aniline-based linkers incorporate an aniline moiety within their structure. This aromatic amine offers unique chemical properties that are particularly advantageous for specific drug delivery strategies, most notably in the context of self-immolative spacers.

Key Characteristics:

- **Self-Immolation:** Aniline linkers are frequently employed in self-immolative systems, such as the widely used para-aminobenzyl carbamate (PABC) spacer.^[9] Following enzymatic cleavage of a nearby trigger (e.g., a dipeptide by cathepsin B), the exposed aniline nitrogen initiates a rapid electronic cascade, leading to the release of the payload.^[9] This mechanism allows for the release of drugs containing functional groups, like amines, that are not directly amenable to cleavage.^{[9][10]}
- **Modulated Reactivity:** The electronic properties of the aniline ring can be tuned through the introduction of substituents, thereby influencing the rate of self-immolation and payload release. This offers a degree of control over the drug release kinetics.
- **Potential for Enhanced Bystander Effect:** Payloads released from aniline-containing linkers can possess physicochemical properties, such as membrane permeability, that facilitate their diffusion into neighboring, antigen-negative tumor cells, leading to a "bystander effect."^[10] This can be particularly beneficial in treating heterogeneous tumors.^[10]
- **Metabolic Considerations:** While useful, the aniline substructure itself can be susceptible to metabolism in the liver, which may lead to the formation of toxic metabolites.^{[11][12]} This is a critical consideration in drug design and safety assessment.^{[11][12]}

Structural Representation of Aniline-Based Self-Immolative Linker

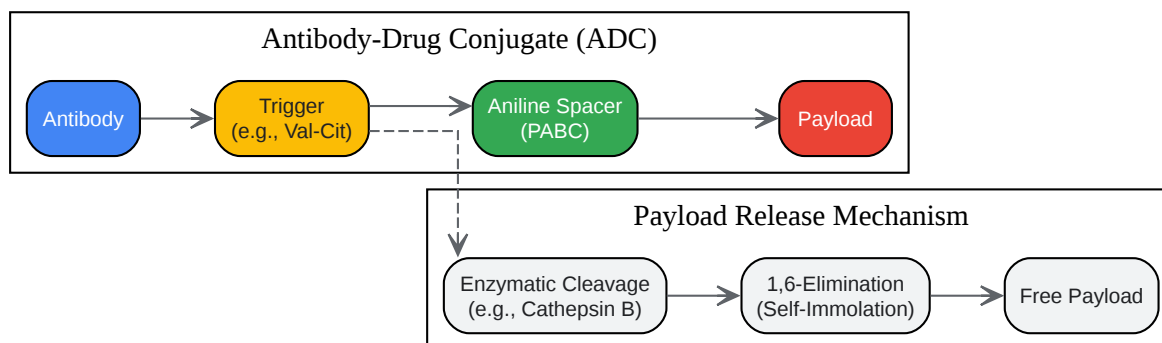

[Click to download full resolution via product page](#)

Caption: Aniline-based self-immolative linker mechanism in an ADC.

Aliphatic Linkers: The Workhorses of Drug Conjugation

Aliphatic linkers are composed of saturated or unsaturated hydrocarbon chains and are the most commonly used linkers in drug design, particularly in PROTACs.[7][8][13] Their popularity stems from their synthetic accessibility and tunable physical properties.

Key Characteristics:

- **Flexibility and Length:** Aliphatic chains, such as alkyl and polyethylene glycol (PEG) chains, provide significant conformational flexibility.[7][8] The length of the linker can be easily adjusted to optimize the spatial orientation between the targeting moiety and the payload, which is crucial for forming a stable ternary complex in PROTACs.[7]
- **Hydrophilicity/Hydrophobicity:** The physicochemical properties of aliphatic linkers can be readily modified. Simple alkyl chains are hydrophobic, which can sometimes limit aqueous solubility.[14] The incorporation of heteroatoms, such as oxygen in PEG linkers, increases hydrophilicity, improving solubility and potentially altering the pharmacokinetic profile.[7][14]
- **Synthetic Tractability:** Aliphatic linkers are generally straightforward to synthesize and incorporate into drug conjugates, facilitating the rapid generation of compound libraries for

structure-activity relationship (SAR) studies.[7][13]

- Metabolic Stability: While generally considered stable, simple alkyl chains can be susceptible to oxidative metabolism.[15] Introducing cyclic elements or other metabolically more robust functionalities can enhance stability.[14]

Structural Representation of a PROTAC with an Aliphatic Linker

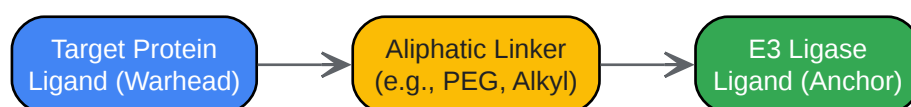

[Click to download full resolution via product page](#)

Caption: A PROTAC molecule featuring an aliphatic linker.

Head-to-Head Comparison: Aniline vs. Aliphatic Linkers

Feature	Aniline Linkers	Aliphatic Linkers
Primary Function	Often part of a self-immolative system for controlled payload release.	Primarily provide spatial separation and optimal orientation between two molecular entities.[7]
Flexibility	Generally more rigid due to the aromatic ring.	Highly flexible, with length and rigidity being tunable.[7]
Solubility	Can be modulated by substituents on the aniline ring.	Readily tunable from hydrophobic (alkyl) to hydrophilic (PEG).[14]
Synthesis	Can be more complex, especially when part of a multi-component release system.	Generally straightforward and amenable to library synthesis. [7][13]
Stability	Stability is dependent on the overall construct; the aniline moiety itself can be metabolically labile.[11][12]	Generally stable, though simple alkyl chains can be prone to oxidative metabolism. [15]
Key Advantage	Enables sophisticated, triggered payload release mechanisms.[9]	High degree of modularity and tunability for optimizing spatial parameters.[7]
Key Disadvantage	Potential for metabolic liabilities and toxicity associated with the aniline core.[11]	High flexibility can lead to an entropic penalty upon binding and potential for non-specific interactions.[15]
Common Applications	Antibody-Drug Conjugates (ADCs) with cleavable, self-immolative linkers.[10][16]	Proteolysis Targeting Chimeras (PROTACs), various bioconjugation applications.[7][8][17]

Experimental Protocols for Linker Evaluation

The rational design of linkers must be supported by rigorous experimental validation. Below are key protocols for assessing linker performance.

Protocol 1: In Vitro Linker Stability Assessment in Plasma

This assay evaluates the stability of the linker in a biologically relevant matrix.

Objective: To determine the rate of premature payload release from a drug conjugate in plasma.

Methodology:

- Preparation of Solutions:
 - Prepare a stock solution of the drug-linker conjugate in an appropriate solvent (e.g., DMSO).
 - Thaw plasma (human, mouse, or rat) at 37°C.
- Incubation:
 - Spike the drug-linker conjugate into the pre-warmed plasma to a final concentration of 1-10 µM.
 - Incubate the mixture at 37°C with gentle agitation.
- Time-Point Sampling:
 - At various time points (e.g., 0, 1, 4, 8, 24, 48 hours), aliquot a portion of the plasma sample.
- Sample Processing:
 - Quench the reaction and precipitate plasma proteins by adding 3 volumes of cold acetonitrile containing an internal standard.
 - Vortex and centrifuge at high speed to pellet the precipitated proteins.

- Analysis:
 - Analyze the supernatant by LC-MS/MS to quantify the amount of intact conjugate and any released payload.[\[18\]](#)
- Data Interpretation:
 - Calculate the half-life ($t_{1/2}$) of the conjugate in plasma. A longer half-life indicates greater stability.[\[15\]](#)

Protocol 2: In Vitro Payload Release Assay

This assay assesses the efficiency of payload release under conditions that mimic the intracellular environment.

Objective: To measure the rate and extent of payload release triggered by a specific mechanism (e.g., enzymatic cleavage).

Methodology:

- Preparation of Reaction Buffers:
 - For enzyme-cleavable linkers, prepare an assay buffer containing the relevant enzyme (e.g., Cathepsin B for Val-Cit linkers) at an appropriate pH (e.g., pH 5.5 to mimic the lysosomal environment).[\[19\]](#)[\[20\]](#)
- Incubation:
 - Add the drug-linker conjugate to the pre-warmed reaction buffer.
 - Initiate the reaction by adding the enzyme.
 - Incubate at 37°C.
- Time-Point Sampling and Quenching:
 - At various time points, take aliquots and quench the reaction (e.g., by adding a protease inhibitor or shifting the pH).

- Analysis:
 - Analyze the samples by LC-MS/MS or HPLC to quantify the concentration of the released payload.
- Data Interpretation:
 - Plot the concentration of the released payload over time to determine the release kinetics.

Workflow for Linker Evaluation

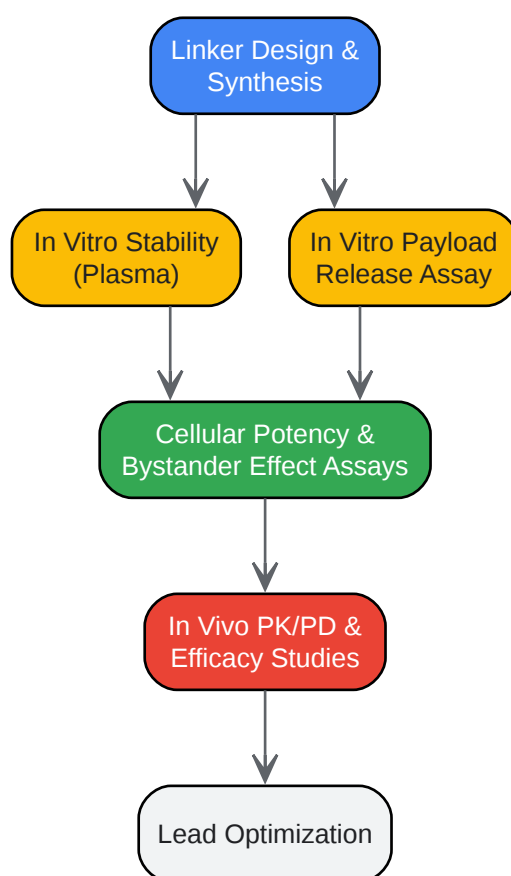

[Click to download full resolution via product page](#)

Caption: A typical workflow for the evaluation of linkers in drug design.

Conclusion and Future Perspectives

The choice between an aniline and an aliphatic linker is not a matter of inherent superiority but rather one of strategic selection based on the specific therapeutic goal. Aniline linkers offer a sophisticated mechanism for controlled, triggered payload release, which is invaluable for many ADC designs. However, their potential metabolic liabilities require careful consideration and mitigation. Aliphatic linkers, with their synthetic tractability and tunable physicochemical properties, provide a versatile platform for optimizing the spatial requirements of bifunctional molecules like PROTACs.

The future of linker technology lies in the development of novel linker constructs that combine the best attributes of different chemical classes. This may include "hybrid" linkers that incorporate both aromatic and aliphatic components to achieve a fine-tuned balance of stability, release kinetics, and pharmacokinetic properties. As our understanding of the complex interplay between linker chemistry and biological systems deepens, so too will our ability to design safer and more effective targeted therapies.

References

- Su, D., et al. (2021). Linker Design Impacts Antibody-Drug Conjugate Pharmacokinetics and Efficacy via Modulating the Stability and Payload Release Efficiency. *Frontiers in Immunology*, 12, 687311. [[Link](#)]
- Kozicka, Z., & Thomä, N. H. (2021). Novel approaches for the rational design of PROTAC linkers. *Open Exploration*, 1(1), 1-12. [[Link](#)]
- Su, D., et al. (2021). Linker Design Impacts Antibody-Drug Conjugate Pharmacokinetics and Efficacy via Modulating the Stability and Payload Release Efficiency. *Frontiers in Immunology*, 12. [[Link](#)]
- Erickson, H. K., et al. (2012). The Effect of Different Linkers on Target Cell Catabolism and Pharmacokinetics/Pharmacodynamics of Trastuzumab Maytansinoid Conjugates. *Molecular Cancer Therapeutics*, 11(5), 1133-1142. [[Link](#)]
- Su, D., et al. (2021). Linker Design Impacts Antibody-Drug Conjugate Pharmacokinetics and Efficacy via Modulating the Stability and Payload Release Efficiency. *ResearchGate*. [[Link](#)]
- Kumar, A., et al. (2021). Chiral Cyclic Aliphatic Linkers as Building Blocks for Selective Dopamine D2 or D3 Receptor Agonists. *Journal of Medicinal Chemistry*, 64(22), 16569-

16592. [\[Link\]](#)

- Kozicka, Z., & Thomä, N. H. (2021). Novel approaches for the rational design of PROTAC linkers. ResearchGate. [\[Link\]](#)
- Bargh, T. J., et al. (2021). Chapter 3: Linker Design and Impact on ADC Properties. In *Antibody-Drug Conjugates* (pp. 56-101). The Royal Society of Chemistry. [\[Link\]](#)
- Kovtun, Y. V., et al. (2015). Development of Anilino-Maytansinoid ADCs that Efficiently Release Cytotoxic Metabolites in Cancer Cells and Induce High Levels of Bystander Killing. *Bioconjugate Chemistry*, 26(9), 1971-1981. [\[Link\]](#)
- Scott, J. S., & Tsoni, S. V. (2021). Current strategies for the design of PROTAC linkers: a critical review. *Essays in Biochemistry*, 65(4), 507-523. [\[Link\]](#)
- Kamal, A., et al. (2022). Drug-Linker Constructs Bearing Unique Dual-Mechanism Tubulin Binding Payloads Tethered through Cleavable and Non-Cleavable Linkers. *Molecules*, 27(19), 6524. [\[Link\]](#)
- D'Amico, L., et al. (2021). In Vivo Testing of Drug-Linker Stability. In *Antibody-Drug Conjugates* (pp. 225-245). Springer Nature. [\[Link\]](#)
- Kim, H., et al. (2021). Assessments of the In Vitro and In Vivo Linker Stability and Catabolic Fate for the Ortho Hydroxy-Protected Aryl Sulfate Linker by Immuno-Affinity Capture Liquid Chromatography Quadrupole Time-of-Flight Mass Spectrometric Assay. *Pharmaceutics*, 13(2), 164. [\[Link\]](#)
- Kovtun, Y. V., et al. (2015). Development of Anilino-Maytansinoid ADCs that Efficiently Release Cytotoxic Metabolites in Cancer Cells and Induce High Levels of Bystander Killing. PubMed. [\[Link\]](#)
- Neumann, C. S., et al. (2018). Targeted Delivery of Cytotoxic NAMPT Inhibitors Using Antibody-Drug Conjugates. ResearchGate. [\[Link\]](#)
- St. Amant, A. H., & Van Vranken, D. L. (2020). Antibody Drug Conjugates: Design and Selection of Linker, Payload and Conjugation Chemistry. *Pharmaceutics*, 13(9), 239. [\[Link\]](#)

- Pavan, M., & Fustero, S. (2020). Innovative linker strategies for tumor-targeted drug conjugates. AIR Unimi. [\[Link\]](#)
- NJ Bio, Inc. (n.d.). Linkers for ADCs. NJ Bio, Inc. Accessed March 11, 2026. [\[Link\]](#)
- BioPartner UK. (2024). Cresset Blog: Aniline replacement in drug-like compounds. BioPartner UK. Accessed March 11, 2026. [\[Link\]](#)
- Jeffrey, S. C., et al. (2016). Development of Novel Quaternary Ammonium Linkers for Antibody–Drug Conjugates. *Molecular Cancer Therapeutics*, 15(5), 938-945. [\[Link\]](#)
- Quora. (2018). Why is aniline a weaker base than an aliphatic amine?. Quora. Accessed March 11, 2026. [\[Link\]](#)
- Wujec, M., et al. (2024). Aniline Derivatives Containing 1-Substituted 1,2,3-Triazole System as Potential Drug Candidates: Pharmacokinetic Profile Prediction, Lipophilicity Analysis Using Experimental and In Silico Studies. *Molecules*, 29(22), 4983. [\[Link\]](#)
- Shugrue, C. R., et al. (2024). Electron-rich anilines as cleavable linkers for peptides. *Bioorganic & Medicinal Chemistry*, 108, 108084. [\[Link\]](#)

Need Custom Synthesis?

BenchChem offers custom synthesis for rare earth carbides and specific isotopic labeling.

Email: info@benchchem.com or [Request Quote Online](#).

Sources

- 1. adc.bocsci.com [adc.bocsci.com]
- 2. books.rsc.org [books.rsc.org]
- 3. adc.bocsci.com [adc.bocsci.com]
- 4. [Frontiers | Linker Design Impacts Antibody-Drug Conjugate Pharmacokinetics and Efficacy via Modulating the Stability and Payload Release Efficiency](https://www.frontiersin.org) [[frontiersin.org](https://www.frontiersin.org)]
- 5. [Linker Design Impacts Antibody-Drug Conjugate Pharmacokinetics and Efficacy via Modulating the Stability and Payload Release Efficiency - PMC](https://pubmed.ncbi.nlm.nih.gov) [[pmc.ncbi.nlm.nih.gov](https://pubmed.ncbi.nlm.nih.gov)]

- 6. adc.bocsci.com [adc.bocsci.com]
- 7. Novel approaches for the rational design of PROTAC linkers [explorationpub.com]
- 8. researchgate.net [researchgate.net]
- 9. air.unimi.it [air.unimi.it]
- 10. pubs.acs.org [pubs.acs.org]
- 11. news.umich.edu [news.umich.edu]
- 12. biopartner.co.uk [biopartner.co.uk]
- 13. Current strategies for the design of PROTAC linkers: a critical review - PMC [pmc.ncbi.nlm.nih.gov]
- 14. precisepeg.com [precisepeg.com]
- 15. pdf.benchchem.com [pdf.benchchem.com]
- 16. Drug-Linker Constructs Bearing Unique Dual-Mechanism Tubulin Binding Payloads Tethered through Cleavable and Non-Cleavable Linkers - PMC [pmc.ncbi.nlm.nih.gov]
- 17. Aliphatic Linkers | BroadPharm [broadpharm.com]
- 18. In Vivo Testing of Drug-Linker Stability | Springer Nature Experiments [experiments.springernature.com]
- 19. A Review on ADC Linkers: Cleavable and Non-Cleavable Linker Design and Stability Evaluation - WuXi AppTec DMPK [dmpk.service.wuxiapptec.com]
- 20. adc.bocsci.com [adc.bocsci.com]
- To cite this document: BenchChem. [Aniline vs. Aliphatic Linkers in Drug Design: A Comparative Guide]. BenchChem, [2026]. [Online PDF]. Available at: [<https://www.benchchem.com/product/b1497819/docs#aniline-vs-aliphatic-linkers-in-drug-design-a-comparative-guide>]

Disclaimer & Data Validity:

The information provided in this document is for Research Use Only (RUO) and is strictly not intended for diagnostic or therapeutic procedures. While BenchChem strives to provide accurate protocols, we make no warranties, express or implied, regarding the fitness of this product for every specific experimental setup.

Technical Support: The protocols provided are for reference purposes. Unsure if this reagent suits your experiment?

Need Industrial/Bulk Grade? [Request Custom Synthesis Quote](#)

BenchChem

Our mission is to be the trusted global source of essential and advanced chemicals, empowering scientists and researchers to drive progress in science and industry.

Contact

Address: 3281 E Guasti Rd
Ontario, CA 91761, United States
Phone: (601) 213-4426
Email: info@benchchem.com

[Contact our Ph.D. Support Team for a compatibility check](#)