

# Application Notes: Quantitative Analysis of Neophellamuretin in Plant Extracts

**Author:** BenchChem Technical Support Team. **Date:** December 2025

## Compound of Interest

Compound Name: *Neophellamuretin*

Cat. No.: *B1493547*

[Get Quote](#)

Audience: Researchers, scientists, and drug development professionals.

## Introduction

**Neophellamuretin** is a flavonoid glycoside found in the bark of *Phellodendron amurense*, commonly known as the Amur cork tree. The bark of this tree, *Cortex Phellodendri*, is a well-documented material in traditional Chinese medicine, utilized for its anti-inflammatory, antibacterial, and antiviral properties.[1][2] Given the therapeutic interest in *Phellodendron amurense* extracts, accurate and reproducible methods for quantifying its bioactive constituents, such as **Neophellamuretin**, are essential for quality control, standardization, and pharmacological research.[3]

This document provides detailed protocols for the extraction of **Neophellamuretin** from plant materials and its subsequent quantitative analysis using High-Performance Liquid Chromatography (HPLC) with UV detection and Liquid Chromatography-Tandem Mass Spectrometry (LC-MS/MS) for enhanced sensitivity and selectivity.

## Principle

The quantitative analysis of **Neophellamuretin** involves two primary stages. First, the compound is extracted from the dried, powdered plant matrix using an efficient method such as ultrasonic-assisted solvent extraction.[4] Following extraction, the crude extract is filtered and prepared for chromatographic analysis. The concentration of **Neophellamuretin** in the extract is then determined by separating it from other matrix components using reverse-phase HPLC

or LC-MS/MS and comparing the instrumental response to that of a certified reference standard.

## Experimental Protocols

### Protocol 1: Ultrasonic-Assisted Extraction of Neophellamuretin

This protocol is adapted from established methods for extracting medicinal components from Phellodendron bark.[4]

#### 3.1.1 Materials and Reagents

- Dried Phellodendron amurense bark
- Grinder or mill
- Methanol (HPLC Grade)
- Hydrochloric Acid (HCl), concentrated
- Deionized Water
- Ultrasonic bath
- Centrifuge and centrifuge tubes (50 mL)
- Rotary evaporator
- 0.22 µm Syringe filters (PTFE or Nylon)

#### 3.1.2 Sample Preparation

- Dry the Phellodendron amurense bark at 60°C until a constant weight is achieved.
- Grind the dried bark into a fine powder (40-60 mesh) to increase the surface area for extraction.
- Store the powder in a desiccator until use.

### 3.1.3 Extraction Procedure

- Accurately weigh approximately 1.0 g of the dried plant powder and place it into a 50 mL centrifuge tube.
- Prepare the extraction solvent: 0.5% HCl in 70% Methanol (v/v/v). For 100 mL, combine 70 mL Methanol, 0.5 mL concentrated HCl, and bring the volume to 100 mL with deionized water.
- Add 25 mL of the extraction solvent to the centrifuge tube containing the plant powder.
- Vortex the mixture for 1 minute to ensure thorough wetting of the powder.
- Place the tube in an ultrasonic bath and sonicate for 45 minutes at 50°C.
- After sonication, centrifuge the mixture at 4000 rpm for 15 minutes.
- Carefully decant the supernatant into a clean flask.
- Repeat the extraction (steps 3-7) on the remaining plant pellet with another 25 mL of extraction solvent to ensure complete extraction.
- Combine the supernatants from both extractions.
- Concentrate the combined extract to dryness using a rotary evaporator under reduced pressure at 50°C.
- Reconstitute the dried residue in a known volume (e.g., 5.0 mL) of methanol.
- Filter the reconstituted solution through a 0.22 µm syringe filter into an HPLC vial for analysis.

## Protocol 2: Quantitative Analysis by HPLC-UV

This is a general method for flavonoid quantification and should be optimized using a pure **Neophellamuretin** standard.<sup>[5][6]</sup>

### 3.2.1 Instrumentation and Conditions

- HPLC system with a quaternary pump, autosampler, column oven, and Diode Array Detector (DAD) or UV-Vis detector.
- Column: C18 reverse-phase column (e.g., 4.6 x 150 mm, 5 µm particle size).
- Mobile Phase A: 0.1% Formic Acid in Water.
- Mobile Phase B: Acetonitrile.
- Flow Rate: 1.0 mL/min.
- Injection Volume: 10 µL.
- Column Temperature: 30°C.
- Detection Wavelength: Monitor at 280 nm or a wavelength determined from the UV spectrum of a **Neophellamuretin** standard.
- Gradient Elution:
  - 0-5 min: 10-25% B
  - 5-20 min: 25-50% B
  - 20-25 min: 50-90% B
  - 25-28 min: 90% B (hold)
  - 28-30 min: 90-10% B (return to initial)
  - 30-35 min: 10% B (equilibration)

### 3.2.2 Procedure

- Standard Preparation: Prepare a stock solution of **Neophellamuretin** reference standard (e.g., 1.0 mg/mL) in methanol. Create a series of calibration standards (e.g., 1, 5, 10, 25, 50, 100 µg/mL) by serially diluting the stock solution.

- **Calibration Curve:** Inject each calibration standard into the HPLC system. Plot the peak area of **Neophellamuretin** against the corresponding concentration to construct a calibration curve. Determine the linearity ( $R^2 > 0.999$ ).
- **Sample Analysis:** Inject the filtered plant extract sample (from Protocol 1).
- **Quantification:** Identify the **Neophellamuretin** peak in the sample chromatogram by comparing its retention time with the standard. Calculate the concentration in the sample using the regression equation from the calibration curve.

## Protocol 3: Quantitative Analysis by LC-MS/MS

This method provides higher sensitivity and is recommended for detecting low concentrations of **Neophellamuretin**.<sup>[7][8]</sup>

### 3.3.1 Instrumentation and Conditions

- LC-MS/MS system with a binary pump, autosampler, column oven, and a triple quadrupole mass spectrometer with an electrospray ionization (ESI) source.
- LC Conditions: Use the same column and mobile phase gradient as described in the HPLC-UV method (Protocol 2.2.1), potentially with a lower flow rate (e.g., 0.4-0.6 mL/min) suitable for MS interfacing.
- MS Conditions:
  - Ionization Mode: ESI Negative (typical for flavonoids).
  - MRM Transitions: These must be determined empirically by infusing a standard solution of **Neophellamuretin**. A precursor ion (Q1) corresponding to its deprotonated molecule  $[M-H]^-$  and a characteristic product ion (Q3) will be selected.
  - Internal Standard (IS): A stable isotope-labeled **Neophellamuretin** or a structurally similar flavonoid not present in the sample should be used for optimal accuracy. The MRM transition for the IS must also be determined.
  - Optimize MS parameters such as capillary voltage, source temperature, gas flows, and collision energy for the specific instrument.

### 3.3.2 Procedure

- **Standard and Sample Preparation:** Prepare calibration standards and process plant samples as described for the HPLC method. Spike all standards and samples with a fixed concentration of the internal standard.
- **Calibration Curve:** Inject the standards and plot the ratio of the analyte peak area to the IS peak area against the analyte concentration.
- **Sample Analysis:** Inject the spiked, filtered plant extract.
- **Quantification:** Calculate the concentration of **Neophellamuretin** in the sample using the regression equation from the area ratio-based calibration curve.

## Data Presentation

Quantitative data should be organized into clear, structured tables for comparison and reporting.

Table 1: HPLC-UV Method Parameters

Parameter	Setting
Column	C18 Reverse Phase (4.6 x 150 mm, 5 µm)
Mobile Phase	A: 0.1% Formic Acid in Water; B: Acetonitrile
Flow Rate	1.0 mL/min
Gradient	10% to 90% B over 25 minutes
Column Temp.	30°C
Injection Vol.	10 µL

| Detection | 280 nm (or optimized wavelength) |

Table 2: LC-MS/MS Method Parameters

Parameter	Setting
LC Parameters	
Column	C18 Reverse Phase (2.1 x 100 mm, 2.7 µm)
Mobile Phase	A: 0.1% Formic Acid in Water; B: Acetonitrile
Flow Rate	0.4 mL/min
MS Parameters	
Ion Source	Electrospray Ionization (ESI)
Polarity	Negative
Neophellamuretin MRM	Q1 (m/z) -> Q3 (m/z) (To be determined)

| Internal Standard MRM | Q1 (m/z) -> Q3 (m/z) (To be determined) |

Table 3: Example Calibration Curve Data

Concentration (µg/mL)	Peak Area (or Area Ratio)
<b>1.0</b>	<b>Insert Data</b>
5.0	Insert Data
10.0	Insert Data
25.0	Insert Data
50.0	Insert Data
100.0	Insert Data
Regression Eq.	$y = mx + c$

|  $R^2$  | > 0.999 |

Table 4: Example Quantitative Results

Sample ID	Weight (g)	Final Vol. (mL)	Conc. ( $\mu\text{g/mL}$ )	Amount (mg/g DW)
<b>Extract 1</b>	<b>1.012</b>	<b>5.0</b>	<b>Calculated</b>	<b>Calculated</b>
Extract 2	1.005	5.0	Calculated	Calculated

| Extract 3 | 1.021 | 5.0 | Calculated | Calculated |

## Visualizations

## Experimental Workflow



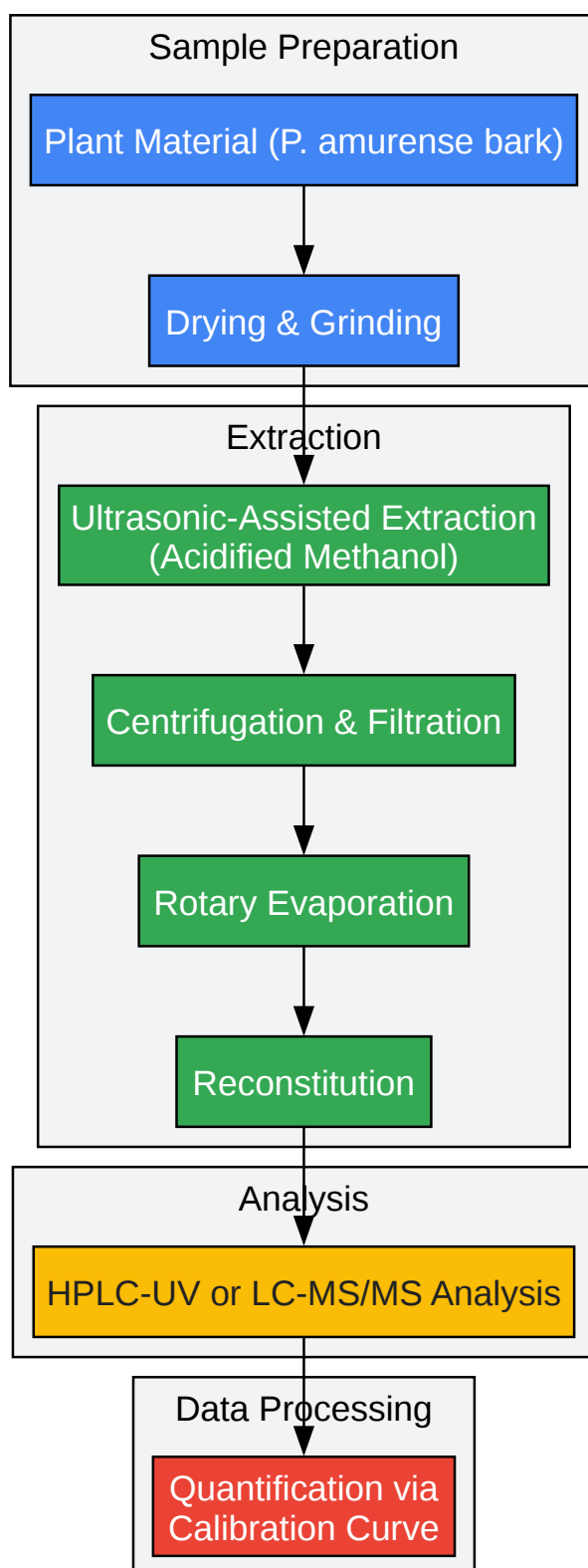

[Click to download full resolution via product page](#)

Caption: Workflow for **Neophellamuretin** Quantification.

## Relevant Signaling Pathway: NF- $\kappa$ B in Inflammation

Phellodendron amurense extracts are noted for their anti-inflammatory effects, a process in which the NF- $\kappa$ B signaling pathway plays a crucial role.[9][10] **Neophellamuretin** may contribute to these effects by modulating this pathway.

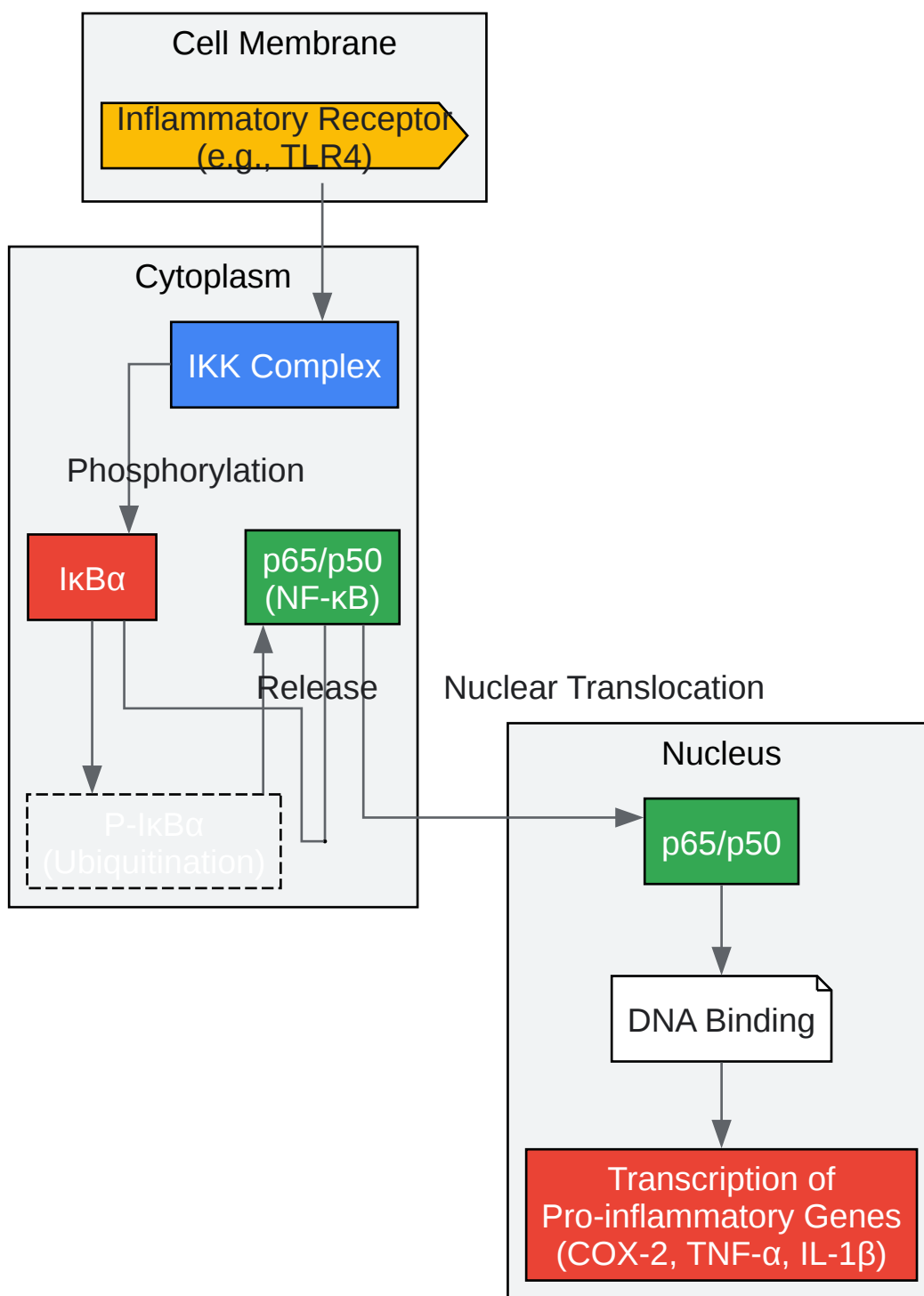

Canonical NF-κB Signaling Pathway

[Click to download full resolution via product page](#)

Caption: Canonical NF-κB Inflammatory Signaling Pathway.

**Need Custom Synthesis?**

BenchChem offers custom synthesis for rare earth carbides and specific isotopic labeling.

Email: [info@benchchem.com](mailto:info@benchchem.com) or [Request Quote Online](#).

## References

- 1. Safety studies of Nexrutine, bark extract of Phellodendron amurense through repeated oral exposure to rats for 28 days - PMC [[pmc.ncbi.nlm.nih.gov](https://pubmed.ncbi.nlm.nih.gov)]
- 2. [saienbiotech.com](https://saienbiotech.com) [[saienbiotech.com](https://saienbiotech.com)]
- 3. [researchgate.net](https://researchgate.net) [[researchgate.net](https://researchgate.net)]
- 4. High-efficient extraction of principal medicinal components from fresh Phellodendron bark (cortex phellodendri) - PMC [[pmc.ncbi.nlm.nih.gov](https://pubmed.ncbi.nlm.nih.gov)]
- 5. [researchgate.net](https://researchgate.net) [[researchgate.net](https://researchgate.net)]
- 6. Improved high-performance liquid chromatography (HPLC) method for qualitative and quantitative analysis of allantoin in Zea mays - PubMed [[pubmed.ncbi.nlm.nih.gov](https://pubmed.ncbi.nlm.nih.gov)]
- 7. [mdpi.com](https://mdpi.com) [[mdpi.com](https://mdpi.com)]
- 8. [mdpi.com](https://mdpi.com) [[mdpi.com](https://mdpi.com)]
- 9. [mdpi.com](https://mdpi.com) [[mdpi.com](https://mdpi.com)]
- 10. Signaling Pathways in Inflammation and Anti-inflammatory Therapies - PubMed [[pubmed.ncbi.nlm.nih.gov](https://pubmed.ncbi.nlm.nih.gov)]
- To cite this document: BenchChem. [Application Notes: Quantitative Analysis of Neophellamuretin in Plant Extracts]. BenchChem, [2025]. [Online PDF]. Available at: [<https://www.benchchem.com/product/b1493547#quantitative-analysis-of-neophellamuretin-in-plant-extracts>]

---

**Disclaimer & Data Validity:**

The information provided in this document is for Research Use Only (RUO) and is strictly not intended for diagnostic or therapeutic procedures. While BenchChem strives to provide accurate protocols, we make no warranties, express or implied, regarding the fitness of this product for every specific experimental setup.

**Technical Support:** The protocols provided are for reference purposes. Unsure if this reagent suits your experiment? [[Contact our Ph.D. Support Team for a compatibility check](#)]

**Need Industrial/Bulk Grade?** [Request Custom Synthesis Quote](#)

## BenchChem

Our mission is to be the trusted global source of essential and advanced chemicals, empowering scientists and researchers to drive progress in science and industry.

### Contact

Address: 3281 E Guasti Rd

Ontario, CA 91761, United States

Phone: (601) 213-4426

Email: [info@benchchem.com](mailto:info@benchchem.com)