

# Technical Support Center: Forced Degradation of Pyrazolone Compounds

**Author:** BenchChem Technical Support Team. **Date:** April 2026

## Compound of Interest

**Compound Name:** 1-(2-aminoethyl)-3-(tert-butyl)-1H-pyrazol-5-ol

**CAS No.:** 2090577-87-8

**Cat. No.:** B1491257

[Get Quote](#)

Current Status: Operational Ticket Queue: Open Subject: Protocol Design & Troubleshooting for Pyrazolone Stress Testing (ICH Q1A/Q1B)

## Introduction: The Pyrazolone Challenge

Welcome to the technical guide for handling Pyrazolone derivatives (e.g., Edaravone, Metamizole, Phenazone). Unlike stable solid-state drugs, pyrazolones are chemically labile "radical scavengers." Their therapeutic efficacy relies on the same reactivity that makes forced degradation studies difficult.

The Core Issue: The pyrazolone ring contains an active methylene group (typically at the C4 position) and an N-N bond that are highly susceptible to oxidation and hydrolysis. Standard "cook-and-look" protocols often destroy these molecules entirely, yielding useless data.

This guide provides a scientifically grounded, self-validating protocol designed to achieve the ICH-recommended 5–20% degradation without obliterating the mass balance.

## Module 1: The Master Protocol (Tier 1 Support)

User Advisory: Do not treat pyrazolones like standard small molecules. They are prone to "runaway degradation" in oxidative and alkaline conditions.

### Recommended Stress Conditions Table

Stress Type	Reagent/Condition	Duration	Target Endpoint	Mechanism
Hydrolysis (Acidic)	0.1 N HCl (Reflux at 60–80°C)	1–8 Hours	Ring Opening	Amide/Hydrazide bond cleavage.
Hydrolysis (Alkaline)	0.01 N NaOH (RT to 40°C)	Monitor closely (mins to hours)	Ring Opening & Oxidation	CRITICAL: High pH promotes the anionic form, which oxidizes rapidly even without added peroxide.
Oxidation	0.3% – 3% H <sub>2</sub> O <sub>2</sub> (RT)	30 min – 4 Hours	C4-Oxidation	Radical attack at C4; formation of 4-oxo and hydrazono derivatives.
Photolysis	1.2M Lux·hr / 200 W·hr/m <sup>2</sup>	1–3 Days	Radical/Dimerization	Photo-induced radical formation (often C4-centered).
Thermal	60°C – 80°C (Dry Heat)	1–7 Days	Decarboxylation/Isomerization	Solid-state degradation (slower than solution).

### Experimental Workflow Visualization

The following diagram outlines the logical flow for executing this protocol, ensuring data integrity from stress to analysis.

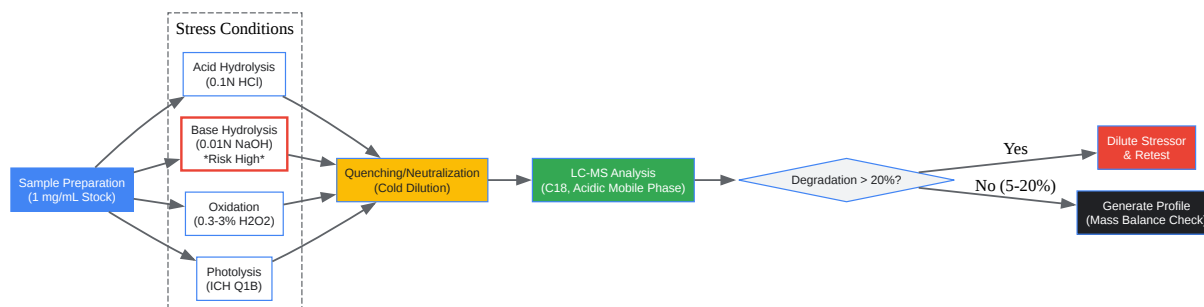

[Click to download full resolution via product page](#)

Caption: Step-by-step workflow for pyrazolone forced degradation. Note the decision loop to prevent over-degradation.

## Module 2: Degradation Mechanisms (Tier 2 Support)

To interpret your chromatograms, you must understand how the molecule breaks.

### Oxidative Pathway (The C4 "Hotspot")

The most critical pathway for pyrazolones (like Edaravone) involves the C4 carbon.

- Mechanism: The pyrazolone exists in equilibrium between keto and enol forms. The enolate anion donates an electron to reactive oxygen species (ROS), forming a radical at C4.
- Key Product: This radical reacts with oxygen to form 4-oxo-edaravone, which often hydrolyzes further to 2-oxo-3-(phenylhydrazono)-butanoic acid (OPB).

- Mass Spec Signature: Look for [M+16] (hydroxylation) and [M+14] (keto formation) peaks.

## Hydrolytic Pathway

- Mechanism: Attack on the amide/hydrazide linkage within the ring.
- Key Product: Ring opening leads to the formation of hydrazine derivatives (e.g., phenylhydrazine) and acetoacetic acid derivatives.
- Mass Spec Signature: Look for significant mass losses corresponding to ring cleavage (e.g., loss of the phenyl group).

## Mechanistic Diagram

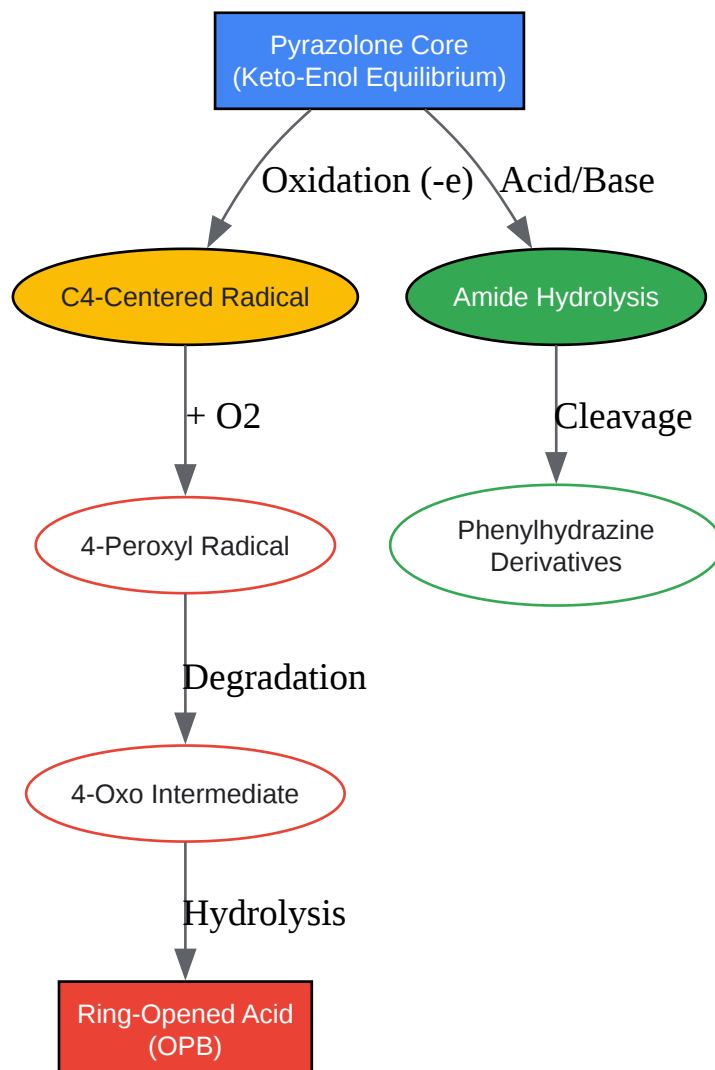

[Click to download full resolution via product page](#)

Caption: Primary degradation pathways. Oxidation targets C4 (Red path); Hydrolysis targets the N-C amide bond (Green path).

## Module 3: Troubleshooting Guide (Tier 3 Support)

### Ticket #101: "My sample turned yellow/brown instantly in NaOH."

- Diagnosis: Rapid oxidative degradation of the pyrazolone anion.
- Explanation: Pyrazolones are acidic (pKa ~7.0). In basic solution (pH > pKa), they exist as anions which are highly electron-rich and react with dissolved oxygen immediately, even without peroxide.
- Solution:
  - Degas all basic solvents using nitrogen sparging or sonication before use.
  - Lower the NaOH concentration to 0.01 N.
  - Perform the stress test in the dark to minimize photo-assisted oxidation.

### Ticket #102: "I see split peaks or broad peaks in my HPLC."

- Diagnosis: Tautomeric equilibrium interference.
- Explanation: Pyrazolones interconvert between CH (keto), OH (enol), and NH forms. If the separation timescale is similar to the interconversion rate, peak splitting occurs.
- Solution:
  - Buffer pH: Ensure your mobile phase pH is well below the pKa (e.g., pH 2.5–3.0) to lock the molecule in the neutral form.

- Temperature: Increasing column temperature (e.g., to 40–50°C) can speed up the interconversion, merging split peaks into a single sharp peak (average signal).

## Ticket #103: "Mass balance is low (< 90%) after oxidative stress."

- Diagnosis: Formation of volatile fragments or insoluble polymers.
- Explanation: Radical-mediated degradation can lead to polymerization (trimers) which may precipitate or get stuck on the column, or small volatile fragments (like CO<sub>2</sub> or small amines) that are not detected.
- Solution:
  - Check the column void volume for polar fragments.
  - Inspect the sample vial for precipitation (polymers).
  - Reduce stressor concentration (e.g., use 0.3% H<sub>2</sub>O<sub>2</sub> instead of 3%) to catch early intermediates rather than end-stage destruction.

## References

- ICH Q1A(R2): Stability Testing of New Drug Substances and Products. International Council for Harmonisation. [Link](#)
- ICH Q1B: Stability Testing: Photostability Testing of New Drug Substances and Products. International Council for Harmonisation. [Link](#)
- Chaudhari, B. G., & Patel, A. B. (2018). Stress degradation of edaravone: Separation, isolation and characterization of major degradation products. Biomedical Chromatography. (Demonstrates the C4-oxidation pathway and OPB formation). [Link](#)
- Yamamoto, Y., et al. (2009). Edaravone, a scavenger for multiple reactive oxygen species, reacts with singlet oxygen to yield 2-oxo-3-(phenylhydrazono)-butanoic acid.[1] Journal of Clinical Biochemistry and Nutrition. (Mechanistic detail on radical scavenging). [Link](#)

- Holzer, W., et al. (2004). On the tautomerism of pyrazolones. Tetrahedron. (Fundamental chemistry regarding keto-enol split peaks). [Link](#)

#### Need Custom Synthesis?

BenchChem offers custom synthesis for rare earth carbides and specific isotopic labeling.

Email: [info@benchchem.com](mailto:info@benchchem.com) or [Request Quote Online](#).

## Sources

- 1. Edaravone, a scavenger for multiple reactive oxygen species, reacts with singlet oxygen to yield 2-oxo-3-(phenylhydrazono)-butanoic acid - PMC [[pmc.ncbi.nlm.nih.gov](https://pubmed.ncbi.nlm.nih.gov/)]
- To cite this document: BenchChem. [Technical Support Center: Forced Degradation of Pyrazolone Compounds]. BenchChem, [2026]. [Online PDF]. Available at: [<https://www.benchchem.com/product/b1491257/docs#technical-support-center-forced-degradation-of-pyrazolone-compounds>]

---

### Disclaimer & Data Validity:

The information provided in this document is for Research Use Only (RUO) and is strictly not intended for diagnostic or therapeutic procedures. While BenchChem strives to provide accurate protocols, we make no warranties, express or implied, regarding the fitness of this product for every specific experimental setup.

**Technical Support:** The protocols provided are for reference purposes. Unsure if this reagent suits your experiment?

**Need Industrial/Bulk Grade?** [Request Custom Synthesis Quote](#)

# BenchChem

Our mission is to be the trusted global source of essential and advanced chemicals, empowering scientists and researchers to drive progress in science and industry.

## Contact

Address: 3281 E Guasti Rd

Ontario, CA 91761, United States

Phone: (601) 213-4426

Email: [info@benchchem.com](mailto:info@benchchem.com)

[Contact our Ph.D. Support Team for a compatibility check](#)