

Optimizing reaction conditions for isoamyl isobutyrate esterification

Author: BenchChem Technical Support Team. **Date:** December 2025

Compound of Interest

Compound Name: *Isoamyl isobutyrate*

Cat. No.: B149016

[Get Quote](#)

Technical Support Center: Isoamyl Isobutyrate Esterification

This technical support center provides troubleshooting guidance and frequently asked questions (FAQs) to assist researchers, scientists, and drug development professionals in optimizing the reaction conditions for **isoamyl isobutyrate** esterification.

Frequently Asked Questions (FAQs)

Q1: What are the general methods for synthesizing **isoamyl isobutyrate**?

A1: **Isoamyl isobutyrate** is typically synthesized through the esterification of isoamyl alcohol with isobutyric acid. This reaction can be catalyzed by either an acid catalyst, such as sulfuric acid (Fischer esterification), or by enzymes, most commonly lipases.[1][2] The choice of catalyst depends on the desired reaction conditions and the intended application of the final product. Enzymatic synthesis is often preferred for producing "natural" flavors and operates under milder conditions.[3]

Q2: What is the primary challenge in **isoamyl isobutyrate** esterification?

A2: A primary challenge in this esterification is that the reaction is reversible and often reaches equilibrium, which can limit the final product yield.[1][4] To overcome this, several strategies can be employed to drive the reaction towards the product side. These include using an excess

of one of the reactants (typically the less expensive one) or removing one of the products (usually water) as it is formed.[1]

Q3: How can I increase the yield of **isoamyl isobutyrate**?

A3: To increase the yield, you can:

- Use an excess of a reactant: Employing a molar excess of either isoamyl alcohol or isobutyric acid can shift the equilibrium towards the formation of the ester.[1][5]
- Remove water: The water produced during the reaction can be removed using techniques like a Dean-Stark apparatus, molecular sieves, or by performing the reaction in a solvent that azeotropically removes water.[6]
- Optimize catalyst concentration: The amount of acid or enzyme catalyst can significantly impact the reaction rate and yield. The optimal concentration should be determined experimentally.
- Control the temperature: While higher temperatures can increase the reaction rate, they can also lead to side reactions or, in the case of enzymatic catalysis, enzyme denaturation. The optimal temperature is a balance between reaction rate and product stability.[2]

Q4: What are the key parameters to optimize for this reaction?

A4: The key parameters to optimize for **isoamyl isobutyrate** esterification include:

- Molar ratio of reactants: The ratio of isoamyl alcohol to isobutyric acid.
- Catalyst concentration: The amount of acid or enzyme used.
- Temperature: The reaction temperature.
- Reaction time: The duration of the reaction.
- Agitation speed: To ensure proper mixing of reactants.
- Solvent: The choice of solvent can influence reaction kinetics and ease of product purification.

Troubleshooting Guide

Problem	Possible Cause(s)	Suggested Solution(s)
Low Yield	The reaction has not reached completion due to equilibrium limitations.	- Use a molar excess of one reactant (e.g., a 1.2:1 ratio of isoamyl alcohol to isobutyric acid).[5]- Remove water as it forms using a Dean-Stark trap or molecular sieves.[6]
Suboptimal reaction temperature.	- For acid catalysis, ensure the reaction is sufficiently heated (reflux).- For enzymatic catalysis, operate within the optimal temperature range of the specific lipase (e.g., around 26.5°C for Rhizomucor miehei lipase).[2]	
Insufficient catalyst.	- Increase the catalyst concentration incrementally. For acid catalysis, a few drops of concentrated sulfuric acid are often sufficient for lab-scale reactions.[4] For enzymatic catalysis, the optimal enzyme/substrate ratio needs to be determined (e.g., 19.6 g/mol for Rhizomucor miehei lipase).[2]	
Reaction time is too short.	- Extend the reaction time. Monitor the reaction progress using techniques like TLC or GC to determine when it has reached completion.	
Slow Reaction Rate	Inadequate mixing.	- Increase the stirring/agitation speed to ensure the reactants are well-mixed.

<p>Low reaction temperature.</p>	<p>- For acid catalysis, increase the temperature to reflux.- For enzymatic catalysis, ensure the temperature is at the optimum for the enzyme being used.</p>	
<p>Low catalyst concentration.</p>	<p>- Gradually increase the amount of catalyst.</p>	
<p>Product Contamination</p>	<p>Presence of unreacted starting materials.</p>	<p>- After the reaction, wash the organic layer with a 5% sodium bicarbonate solution to remove unreacted isobutyric acid.[4]- Use an excess of one reactant to ensure the other is fully consumed, and then remove the excess reactant during purification.</p>
<p>Presence of byproducts.</p>	<p>- Optimize reaction conditions (especially temperature) to minimize side reactions.- Purify the product using distillation or chromatography.</p>	
<p>Enzyme Inactivation (for enzymatic synthesis)</p>	<p>High concentration of butyric acid.</p>	<p>- High concentrations of butyric acid can cause a drop in the pH of the enzyme's microenvironment, leading to inactivation. Consider a fed-batch approach where the acid is added gradually.</p>
<p>Temperature is too high.</p>	<p>- Operate at the optimal temperature for the specific lipase to avoid denaturation.</p>	

Optimized Reaction Conditions

The optimal conditions for **isoamyl isobutyrate** synthesis can vary depending on the catalytic method used. Below are examples of optimized conditions from the literature.

Table 1: Optimized Conditions for **Isoamyl Isobutyrate** Synthesis

Parameter	Acid Catalysis (Ionic Liquid)[5]	Enzymatic Catalysis (Lipase)[2]
Catalyst	bis-(3-methyl-1-imidazole) butylidene double bisulfate (MTEIMHS)	Rhizomucor miehei lipase (Lipozyme IM-20)
Molar Ratio (Alcohol:Acid)	1.2:1	N/A (Substrate concentration optimized)
Catalyst Loading	2.0 g	19.6 g/mol (Enzyme/Substrate Ratio)
Substrate Concentration	N/A	2.5 M
Temperature	N/A	26.5 °C
Reaction Time	3.5 hours	18 hours
Yield	95.4%	2.2 M (Ester Yield)

Experimental Protocols

Protocol 1: Acid-Catalyzed Esterification (Fischer Esterification)

This protocol is adapted from the synthesis of isoamyl acetate and is a general procedure for Fischer esterification.[4]

Materials:

- Isoamyl alcohol

- Isobutyric acid
- Concentrated sulfuric acid (catalyst)
- 5% Sodium bicarbonate solution
- Anhydrous sodium sulfate
- Round-bottom flask
- Reflux condenser
- Heating mantle or water bath
- Separatory funnel
- Beakers and Erlenmeyer flasks

Procedure:

- To a round-bottom flask, add isoamyl alcohol and isobutyric acid (a slight excess of one reactant, e.g., a 1.2 molar ratio of alcohol to acid, can be used).
- Carefully add a few drops of concentrated sulfuric acid to the flask while swirling.
- Add a boiling chip and assemble a reflux apparatus.
- Heat the mixture to reflux for 1-2 hours.
- Allow the reaction mixture to cool to room temperature.
- Transfer the mixture to a separatory funnel.
- Wash the organic layer sequentially with:
 - Water
 - 5% sodium bicarbonate solution (to neutralize the acid catalyst and unreacted isobutyric acid). Be sure to vent the separatory funnel frequently as CO₂ will be generated.

- Water
- Brine (saturated NaCl solution)
- Drain the organic layer into a clean, dry Erlenmeyer flask.
- Dry the organic layer over anhydrous sodium sulfate.
- Decant the dried liquid into a distillation apparatus.
- Purify the **isoamyl isobutyrate** by simple distillation.

Visualizations

Experimental Workflow

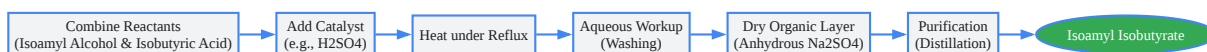

[Click to download full resolution via product page](#)

Caption: Experimental workflow for acid-catalyzed esterification.

Reaction Pathway

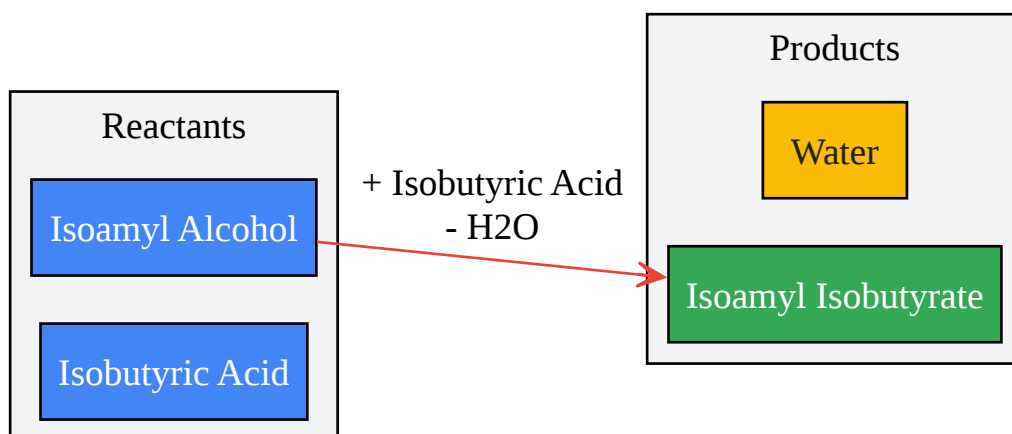

[Click to download full resolution via product page](#)

Caption: General reaction pathway for **isoamyl isobutyrate** synthesis.

Need Custom Synthesis?

BenchChem offers custom synthesis for rare earth carbides and specific isotopic labeling.

Email: info@benchchem.com or [Request Quote Online](#).

References

- 1. masterorganicchemistry.com [masterorganicchemistry.com]
- 2. researchgate.net [researchgate.net]
- 3. researchgate.net [researchgate.net]
- 4. westfield.ma.edu [westfield.ma.edu]
- 5. Study of Catalyzed Synthesis of Ester by Acid Functionalized Dacational Ionic Liqiud [xb.neepu.edu.cn]
- 6. Synthesis of Isoamyl Fatty Acid Ester, a Flavor Compound, by Immobilized Rhodococcus Cutinase - PMC [pmc.ncbi.nlm.nih.gov]
- To cite this document: BenchChem. [Optimizing reaction conditions for isoamyl isobutyrate esterification]. BenchChem, [2025]. [Online PDF]. Available at: [https://www.benchchem.com/product/b149016#optimizing-reaction-conditions-for-isoamyl-isobutyrate-esterification]

Disclaimer & Data Validity:

The information provided in this document is for Research Use Only (RUO) and is strictly not intended for diagnostic or therapeutic procedures. While BenchChem strives to provide accurate protocols, we make no warranties, express or implied, regarding the fitness of this product for every specific experimental setup.

Technical Support: The protocols provided are for reference purposes. Unsure if this reagent suits your experiment? [[Contact our Ph.D. Support Team for a compatibility check](#)]

Need Industrial/Bulk Grade? [Request Custom Synthesis Quote](#)

BenchChem

Our mission is to be the trusted global source of essential and advanced chemicals, empowering scientists and researchers to drive progress in science and industry.

Contact

Address: 3281 E Guasti Rd

Ontario, CA 91761, United States

Phone: (601) 213-4426

Email: info@benchchem.com