

Mass Spectrometry Fragmentation Patterns of Dioxane Carboxylic Acids: A Comparative Analytical Guide

Author: BenchChem Technical Support Team. **Date:** March 2026

Compound of Interest

Compound Name:	2-Methyl-1,3-dioxane-5-carboxylic acid
CAS No.:	138943-97-2
Cat. No.:	B149718

[Get Quote](#)

Executive Summary Dioxane carboxylic acids, specifically 1,4-dioxane-2-carboxylic acid and its metabolic isomers (e.g., HEAA), represent a critical analytical challenge in pharmaceutical impurity profiling and metabolic toxicology. Unlike the stable parent 1,4-dioxane, these carboxylated derivatives exhibit high polarity, thermal instability, and isomer-dependent fragmentation.

This guide compares the two dominant analytical architectures—Gas Chromatography-Mass Spectrometry (GC-MS) via Derivatization and Liquid Chromatography-Tandem Mass Spectrometry (LC-MS/MS)—providing mechanistic insights into their fragmentation physics to enable precise structural elucidation.

Part 1: Structural Dynamics & Ionization Physics

The fragmentation of dioxane carboxylic acids is dictated by the ionization energy applied and the stability of the dioxane ring versus the pendant carboxylic group.

Electron Ionization (EI) – The "Hard" Fingerprint

In GC-MS, the analyte must be derivatized (typically silylated) to survive the injector port. The resulting fragmentation is high-energy (70 eV).

- Mechanism: The molecular ion ($M+[1]^\bullet$) is formed but is often unstable. The radical cation triggers

-cleavage adjacent to the ether oxygen or the carbonyl group.

- Key Feature: The "shattering" effect provides a reproducible spectral fingerprint useful for library matching, but often obliterates the molecular ion peak.

Electrospray Ionization (ESI) – The "Soft" Quantifier

In LC-MS, the analyte is ionized in the liquid phase, typically in Negative Mode (ESI-) due to the acidic proton (

).

- Mechanism: Formation of the deprotonated pseudomolecular ion
 . Fragmentation is induced via Collision-Induced Dissociation (CID).[2]
- Key Feature: Preserves the molecular weight information. The fragmentation is charge-directed, primarily driven by decarboxylation.

Part 2: The Fragmentation Fingerprint (Mechanism)

The following Graphviz diagram details the orthogonal fragmentation pathways. Note the distinct divergence between the Derivatized (EI) and Native (ESI) pathways.

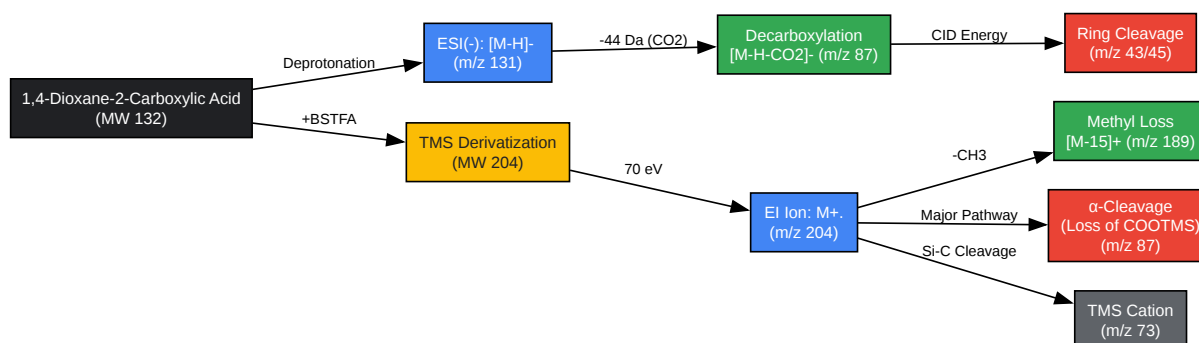

[Click to download full resolution via product page](#)

Figure 1: Orthogonal fragmentation pathways for 1,4-dioxane-2-carboxylic acid. ESI favors decarboxylation (m/z 131 \rightarrow 87), while EI (TMS derivative) favors alpha-cleavage and silyl-specific ions (m/z 73, 189).

Detailed Mechanistic Analysis[3]

A. ESI-MS/MS (Negative Mode)

The primary transition used for quantification (MRM) relies on the instability of the carboxyl group on the ether ring.

- Precursor: m/z 131
.
- Primary Product (m/z 87): The loss of 44 Da () is the dominant channel. The resulting anion (cyclic ether radical) is stabilized by the oxygen atoms.
- Secondary Product (m/z 45): At higher collision energies, the dioxane ring opens, generating glycolate-like fragments ().

B. GC-MS (EI) of TMS Derivative

Direct injection of the acid leads to poor peak shape. Silylation (adding trimethylsilyl groups) creates a volatile ester.

- Precursor: m/z 204 (Molecular Ion of TMS-ester).
- Base Peak (m/z 87): The bond between the dioxane ring and the carbonyl carbon is weak. Cleavage expels the TMS-carboxyl radical, leaving the dioxanyl cation (m/z 87). Note: This is isobaric to the ESI fragment but has a positive charge.
- Diagnostic Peak (m/z 73):

is ubiquitous in TMS derivatives, confirming the success of the derivatization.

Part 3: Comparative Performance Guide

This table objectively compares the two methodologies for researchers selecting an assay.

Feature	Method A: GC-MS (EI)	Method B: LC-MS/MS (ESI)
Analyte Form	TMS-Ester Derivative (Requires Prep)	Native Acid (Direct Analysis)
Sensitivity (LOD)	Moderate (10–50 ppb)	High (0.1–1 ppb)
Specificity	High (Structural Fingerprint)	Medium (Isobaric Interferences possible)
Key Fragment	m/z 87 (Dioxanyl cation)	m/z 87 (Decarboxylated anion)
Sample Throughput	Low (30 min prep + 20 min run)	High (Direct inject + 5 min run)
Interference Risk	Low (Chromatographic resolution high)	High (HEAA interference common)
Primary Use Case	Unknown Identification / Confirmation	Routine Quantitation / biological matrices

Part 4: Experimental Protocols

Protocol A: Derivatization for GC-MS (Structural Confirmation)

Objective: To volatilize the carboxylic acid for electron impact ionization.

- Dry Down: Evaporate 100 μ L of sample extract to complete dryness under stream at 40°C. Critical: Any residual water will quench the derivatizing agent.
- Reconstitution: Add 50 μ L of anhydrous pyridine.
- Derivatization: Add 50 μ L of BSTFA + 1% TMCS (N,O-Bis(trimethylsilyl)trifluoroacetamide).

- Incubation: Vortex and heat at 60°C for 30 minutes.
- Analysis: Inject 1 µL into GC-MS (Splitless).
 - Column: 5% Phenyl-arylene (e.g., DB-5MS).
 - Temp Program: Hold 50°C (1 min) → Ramp 15°C/min → 280°C.

Protocol B: Direct LC-MS/MS (High-Throughput Quantitation)

Objective: To quantify trace levels in biological or aqueous matrices without artifacts.

- Dilution: Dilute sample 1:1 with Methanol/Water (50:50).
- Column: C18 Reverse Phase (High aqueous stability, e.g., Acquity HSS T3), 2.1 x 100 mm, 1.8 µm.
- Mobile Phase:
 - A: 0.1% Formic Acid in Water.
 - B: 0.1% Formic Acid in Acetonitrile.[3]
- Gradient: 0-1 min (5% B); 1-4 min (Linear to 90% B).
- MS Parameters (Source: ESI-):
 - Capillary: 2.5 kV.
 - Cone Voltage: 30 V.
 - MRM Transition: 131.0
87.0 (Quant), 131.0
45.0 (Qual).

Part 5: References

- United States Environmental Protection Agency (EPA). (2023). Method 522: Determination of 1,4-Dioxane in Drinking Water by Solid Phase Extraction and Gas Chromatography/Mass Spectrometry (GC/MS) with Selected Ion Monitoring (SIM).[Link](#)
- Nannelli, A., et al. (2005). Metabolism and toxicokinetics of 1,4-dioxane in humans after inhalational exposure. Archives of Toxicology. [Link](#) (Describing HEAA and dioxane acid metabolites).
- Doc Brown's Chemistry. (2025). Interpreting the fragmentation pattern of the mass spectrum of 1,4-dioxane.[Link](#)
- National Institute of Standards and Technology (NIST). (2023). 1,4-Dioxane-2,6-dione Mass Spectrum.[4] NIST Chemistry WebBook, SRD 69. [Link](#)
- Sigma-Aldrich. (2024). 1,4-Dioxane-2-carboxylic acid Product Specification and CAS Data.[Link](#)

Need Custom Synthesis?

BenchChem offers custom synthesis for rare earth carbides and specific isotopic labeling.

Email: info@benchchem.com or [Request Quote Online](#).

Sources

- [1. mass spectrum of 1,4-dioxane C4H8O2 fragmentation pattern of m/z m/e ions for analysis and identification of para-dioxane image diagram doc brown's advanced organic chemistry revision notes \[docbrown.info\]](#)
- [2. uab.edu \[uab.edu\]](#)
- [3. Comparison of LC-MS-based methods for the determination of carboxylic acids in animal matrices - PMC \[pmc.ncbi.nlm.nih.gov\]](#)
- [4. 1,4-Dioxane-2,6-dione \[webbook.nist.gov\]](#)
- To cite this document: BenchChem. [Mass Spectrometry Fragmentation Patterns of Dioxane Carboxylic Acids: A Comparative Analytical Guide]. BenchChem, [2026]. [Online PDF].

Available at: [<https://www.benchchem.com/product/b149718#mass-spectrometry-fragmentation-patterns-of-dioxane-carboxylic-acids>]

Disclaimer & Data Validity:

The information provided in this document is for Research Use Only (RUO) and is strictly not intended for diagnostic or therapeutic procedures. While BenchChem strives to provide accurate protocols, we make no warranties, express or implied, regarding the fitness of this product for every specific experimental setup.

Technical Support: The protocols provided are for reference purposes. Unsure if this reagent suits your experiment? [[Contact our Ph.D. Support Team for a compatibility check](#)]

Need Industrial/Bulk Grade? [Request Custom Synthesis Quote](#)

BenchChem

Our mission is to be the trusted global source of essential and advanced chemicals, empowering scientists and researchers to drive progress in science and industry.

Contact

Address: 3281 E Guasti Rd
Ontario, CA 91761, United States
Phone: (601) 213-4426
Email: info@benchchem.com