

Application Note: Strategic Protection of Carboxyl Groups via Dioxane Scaffolds

Author: BenchChem Technical Support Team. **Date:** March 2026

Compound of Interest

Compound Name: *2-Methyl-1,3-dioxane-5-carboxylic acid*

CAS No.: 138943-97-2

Cat. No.: B149718

[Get Quote](#)

Methodology: The 1,3-Dioxan-4-one Protocol for

-Hydroxy Acids Date: October 2025 Version: 2.1

Executive Summary

This guide details the protection of carboxyl groups through the formation of 1,3-dioxan-4-one scaffolds. Unlike simple esterification (e.g., methyl or t-butyl esters), this method involves the simultaneous masking of a carboxylic acid and a

-hydroxyl group within a six-membered cyclic acetal. This "bridged" protection strategy is indispensable in the synthesis of polyketides, macrolides, and statins (e.g., Atorvastatin intermediates). It serves a dual purpose: providing robust chemical protection against basic and nucleophilic reagents while rigidly locking the molecular conformation to enable high-fidelity stereoselective transformations (Seebach's Self-Regeneration of Stereocenters).

Scientific Mechanism & Strategic Advantages[1]

The Chemistry of the Dioxane Scaffold

The formation of a 1,3-dioxan-4-one ring proceeds via an acid-catalyzed condensation between a

-hydroxy carboxylic acid and a carbonyl equivalent (aldehyde, ketone, or acetal). This creates a hemiacetal intermediate that cyclizes to form the thermodynamically stable six-membered ring.

Key Structural Features:

- **Conformational Lock:** The dioxane ring forces the backbone into a chair conformation. Substituents at the 2-position (from the aldehyde/ketone) typically adopt an equatorial orientation to minimize 1,3-diaxial interactions.
- **Stereoelectronic Control:** This rigidity allows for highly diastereoselective alkylations at the α -carbon, a technique pioneered by Dieter Seebach.

Advantages Over Standard Esters

| Feature | Standard Ester (e.g., Methyl/Ethyl) | Dioxane Scaffold (1,3-Dioxan-4-one) |
|---------------|-------------------------------------|--|
| Scope | Protects -COOH only | Protects -COOH and -OH simultaneously |
| Conformation | Flexible (free rotation) | Rigid (defined chair conformation) |
| Stereocontrol | Low (requires external auxiliaries) | High (substrate-controlled diastereoselectivity) |
| Stability | Labile to strong bases/nucleophiles | Stable to bases, organolithiums, and hydrides |
| Deprotection | Hydrolysis (Base/Acid) | Acidic Hydrolysis / Transacetalization |

Mechanistic Pathway (DOT Visualization)

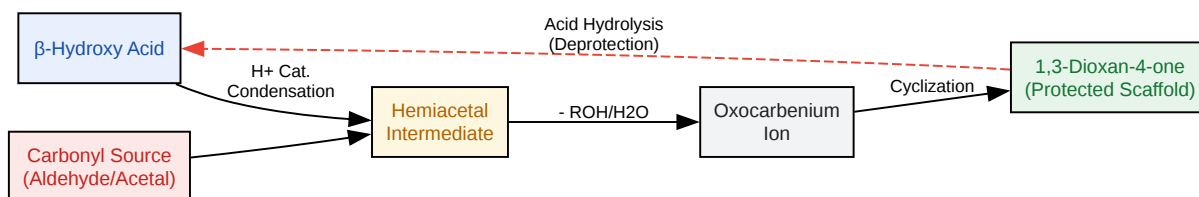

[Click to download full resolution via product page](#)

Caption: Acid-catalyzed formation of the 1,3-dioxan-4-one scaffold from a

β -hydroxy acid. The reaction is reversible, requiring water removal to drive completion.[1]

Experimental Protocols

Protocol A: Synthesis of 2,2-Dimethyl-1,3-dioxan-4-ones (Acetonides)

Best for: Routine protection, stability to mild bases, NMR simplicity.

Reagents:

- β -Hydroxy carboxylic acid (1.0 equiv)
- 2,2-Dimethoxypropane (DMP) (3.0–5.0 equiv)
- *p*-Toluenesulfonic acid monohydrate ($TsOH \cdot H_2O$) (0.05 equiv)
- Solvent: Anhydrous Acetone or CH_2Cl_2

Step-by-Step Methodology:

- Preparation: In a flame-dried round-bottom flask under inert atmosphere (N_2/Ar), dissolve the β -hydroxy acid in anhydrous acetone (0.2 M concentration).
- Acetalization: Add 2,2-dimethoxypropane (DMP). DMP acts as both the reagent and a water scavenger (producing methanol).
- Catalysis: Add catalytic $TsOH$ (5 mol%).

- Reaction: Stir at room temperature for 2–4 hours. Monitor by TLC (stain with KMnO_4 or PMA; the product is less polar than the starting acid).
 - Note: If the reaction is sluggish, heat to reflux. For strictly anhydrous conditions, add activated 4Å molecular sieves.
- Quench: Neutralize the acid catalyst by adding Et_3N (0.1 equiv) or solid NaHCO_3 . Stir for 10 minutes.
- Workup: Filter off solids (if sieves/ NaHCO_3 used). Concentrate the filtrate under reduced pressure.
- Purification: The residue is often pure enough for subsequent steps. If necessary, purify via flash column chromatography (typically Hexanes/ EtOAc). Caution: Silica gel is slightly acidic and can cause hydrolysis; add 1% Et_3N to the eluent.

Protocol B: Synthesis of 2-Aryl-1,3-dioxan-4-ones (Benzylidene Acetals)

Best for: Creating a specific stereocenter at C2 (Seebach's SRS), UV visualization, and higher stability.

Reagents:

- -Hydroxy carboxylic acid (1.0 equiv)
- Benzaldehyde (1.2 equiv) or Benzaldehyde dimethyl acetal (1.5 equiv)
- Acid Catalyst: PPTS (Pyridinium p-toluenesulfonate) or TsOH
- Solvent: Benzene or Toluene (for azeotropic removal of water)

Step-by-Step Methodology:

- Setup: Equip a flask with a Dean-Stark trap and a reflux condenser.
- Dissolution: Suspend the

-hydroxy acid and benzaldehyde in toluene (0.1 M).

- Reflux: Add the acid catalyst (10 mol%) and heat to reflux.
- Water Removal: Maintain reflux until water collection in the Dean-Stark trap ceases (typically 4–12 hours).
 - Why: Unlike Protocol A (where DMP consumes water chemically), this method relies on physical removal of water to drive the equilibrium.
- Workup: Cool to room temperature. Wash the organic layer with saturated aqueous NaHCO_3 and brine.
- Isolation: Dry over MgSO_4 , filter, and concentrate.
- Crystallization: 2-Aryl-1,3-dioxan-4-ones are often crystalline solids. Recrystallize from Hexanes/ Et_2O to obtain a single diastereomer (usually the cis-isomer where the phenyl group is equatorial).

Protocol C: Deprotection (Scaffold Cleavage)

Mechanism: Acid-catalyzed hydrolysis or transesterification.

Method 1: Mild Hydrolysis (Preserves other esters)

- Dissolve the protected dioxane in THF/ H_2O (4:1).
- Add AcOH (acetic acid, 3.0 equiv) or PPTS.
- Heat to 40–60°C for 2–6 hours.
- Concentrate and lyophilize to recover the hydroxy acid.

Method 2: Transesterification (Converts directly to methyl ester)

- Dissolve the dioxane in anhydrous Methanol.
- Add catalytic H_2SO_4 or acetyl chloride (generates HCl in situ).

- Stir at room temperature for 1 hour.
- Result: The dioxane ring opens, yielding the methyl ester of the
-hydroxy acid.

Troubleshooting & Critical Parameters

| Problem | Root Cause | Solution |
|------------------------------|--|---|
| Incomplete Reaction | Equilibrium limitation (Water present) | Use a Dean-Stark trap (Protocol B) or fresh DMP/molecular sieves (Protocol A). |
| Product Hydrolysis on Column | Silica gel acidity | Pre-treat silica column with 1% Et ₃ N/Hexanes; elute rapidly. |
| Epimerization at -Carbon | Basic workup too harsh | Use mild buffers (phosphate pH 7) instead of strong bases; keep temperature low. |
| Poor Solubility | Highly polar amino/hydroxy acids | Use DMF or DMSO as cosolvent; use TsOH in refluxing benzene to force dissolution. |

Case Study: Seebach's Self-Regeneration of Stereocenters (SRS)

The 1,3-dioxan-4-one scaffold is not just a protecting group; it is a chiral auxiliary. By forming a chiral acetal from an optically pure

-hydroxy acid (e.g., derived from 3-hydroxybutyric acid), the original stereocenter "hands off" its chirality to the new acetal center (C2). This allows the original center to be destroyed (via enolization) and regenerated with high diastereoselectivity.

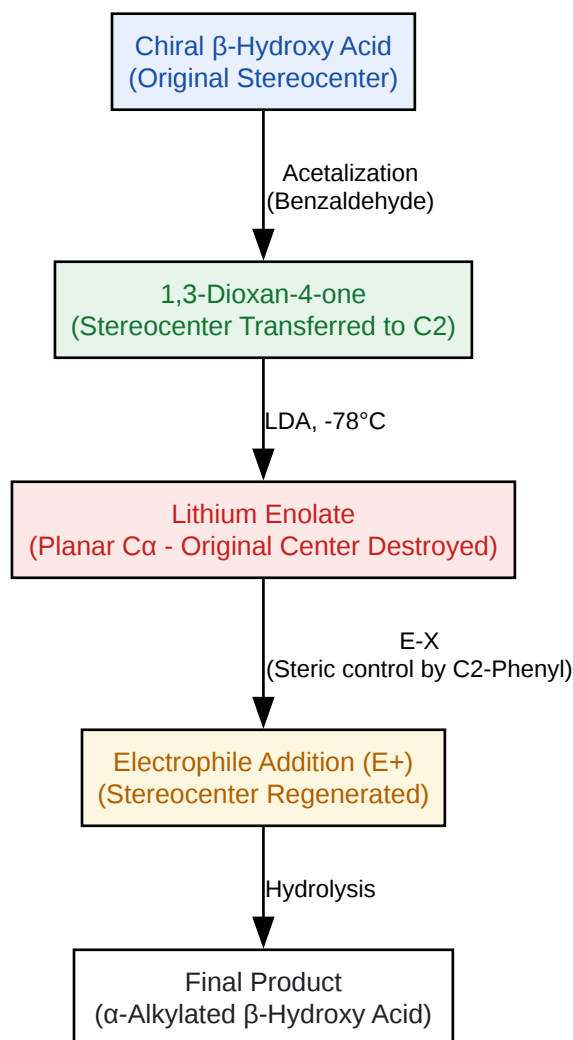

[Click to download full resolution via product page](#)

Caption: Workflow for Seebach's SRS using the dioxane scaffold to alkylate

-hydroxy acids stereoselectively.

References

- Seebach, D., Imwinkelried, R., & Weber, T. (1986).[2] "EPC Syntheses with C,C Bond Formation via Acetals and Enamines." *Modern Synthetic Methods*, 4, 125–259. [Link](#)
- Greene, T. W., & Wuts, P. G. M. (2014). *Greene's Protective Groups in Organic Synthesis* (5th ed.). Wiley. (See Chapter 5: Protection of Carboxyl Groups). [Link](#)

- Kocienski, P. J. (2005). Protecting Groups (3rd ed.). Thieme. (Detailed discussion on 1,3-dioxanes). [Link](#)
- Hoyewicz, J., & Seebach, D. (1988).
-Hydroxy Acids." Helvetica Chimica Acta, 71(8), 1824–1839. [Link](#)
- BenchChem Technical Support. (2025). "Application Note: Protecting Group Chemistry of the 1,3-Dioxane Moiety." BenchChem Application Notes. [Link](#)

Need Custom Synthesis?

BenchChem offers custom synthesis for rare earth carbides and specific isotopic labeling.

Email: info@benchchem.com or [Request Quote Online](#).

Sources

- [1. pdf.benchchem.com \[pdf.benchchem.com\]](https://pdf.benchchem.com)
- [2. Thieme E-Books & E-Journals \[thieme-connect.de\]](https://thieme-connect.de)
- To cite this document: BenchChem. [Application Note: Strategic Protection of Carboxyl Groups via Dioxane Scaffolds]. BenchChem, [2026]. [Online PDF]. Available at: [\[https://www.benchchem.com/product/b149718#methods-for-protecting-carboxyl-groups-using-dioxane-scaffolds\]](https://www.benchchem.com/product/b149718#methods-for-protecting-carboxyl-groups-using-dioxane-scaffolds)

Disclaimer & Data Validity:

The information provided in this document is for Research Use Only (RUO) and is strictly not intended for diagnostic or therapeutic procedures. While BenchChem strives to provide accurate protocols, we make no warranties, express or implied, regarding the fitness of this product for every specific experimental setup.

Technical Support: The protocols provided are for reference purposes. Unsure if this reagent suits your experiment? [[Contact our Ph.D. Support Team for a compatibility check](#)]

Need Industrial/Bulk Grade? [Request Custom Synthesis Quote](#)

BenchChem

Our mission is to be the trusted global source of essential and advanced chemicals, empowering scientists and researchers to drive progress in science and industry.

Contact

Address: 3281 E Guasti Rd

Ontario, CA 91761, United States

Phone: (601) 213-4426

Email: info@benchchem.com