

Technical Support Center: MRS 2211 Validation & Control

Author: BenchChem Technical Support Team. **Date:** May 2026

Compound of Interest

Compound Name: MRS 2211

Cat. No.: B1489678

[Get Quote](#)

Topic: Control Experiments for Validating MRS 2211 Effects

Introduction: The "Selectivity Trap" in P2Y13 Research

Welcome to the **MRS 2211** Technical Support Center. If you are here, you are likely observing a phenotype—reduced platelet aggregation, altered HDL endocytosis, or changes in osteoblast function—and you need to confirm it is mediated specifically by the P2Y13 receptor.

The Challenge: **MRS 2211** is a competitive antagonist with a pIC

of ~6.0 at the P2Y13 receptor. While it is often marketed as "selective," it displays only a >20-fold selectivity window over P2Y1 and P2Y12. In the context of purinergic signaling, where ligands (ADP) are shared and receptor homology is high, this window is narrow. High concentrations (>10 μM) or high physiological doses can and will block P2Y12 and P2Y1, leading to false positives.

This guide provides the rigorous control experiments required to publish **MRS 2211** data with confidence.

Module 1: The "Exclusionary Logic" Protocol (P2Y1/P2Y12 Interference)

User Question: "I see inhibition of ADP-induced calcium flux/aggregation with **MRS 2211**. How do I know I'm not just blocking P2Y12?"

Technical Insight: ADP activates P2Y1 (Gq-coupled, Ca²⁺ mobilization), P2Y12 (Gi-coupled, cAMP inhibition), and P2Y13 (Gi-coupled). Because **MRS 2211** has affinity for all three (albeit lower for P2Y1/12), you cannot rely on **MRS 2211** alone. You must use an Exclusionary Blockade Strategy.

Protocol: The Double-Blockade Validation Assay

This experiment isolates the P2Y13 signal by pharmacologically silencing its "cousins."

Reagents Required:

- Agonist: ADP or 2-MeSADP (Potent P2Y1/12/13 agonist).
- P2Y1 Blocker: MRS 2500 (Highly selective, nanomolar affinity).
- P2Y12 Blocker: Cangrelor or PSB 0739 (Highly selective).^{[1][2]}
- Target: **MRS 2211**.

Workflow:

- Baseline: Establish the maximal response to ADP (e.g., 10 μ M) in your system.
- The Exclusion Step: Pre-incubate cells with MRS 2500 (1 μ M) + Cangrelor (1 μ M).
 - Note: This blocks the dominant aggregation/calcium pathways.
- The Challenge: Add ADP.
 - Observation: If a residual signal remains (e.g., RhoA activation or residual cAMP inhibition), this is likely P2Y13-mediated.

- The Validation: In a parallel well, pre-incubate MRS 2500 + Cangrelor + **MRS 2211** (10 μ M).
 - Result: If the residual signal from Step 3 is abolished, you have confirmed P2Y13 activity.

Visualization: The Exclusionary Logic Flow

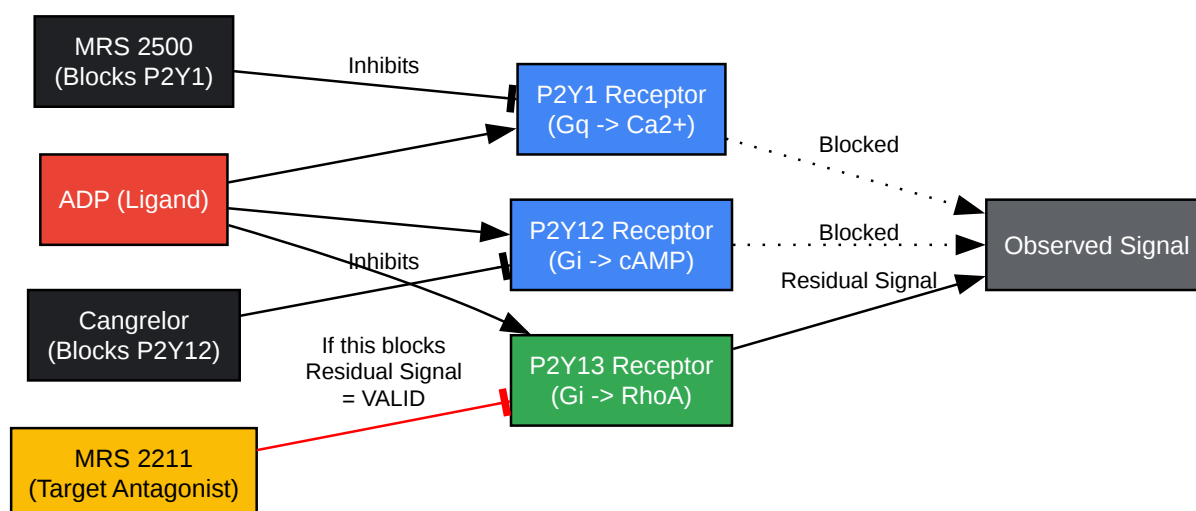

[Click to download full resolution via product page](#)

Caption: Logical flow for isolating P2Y13 activity. The "Residual Signal" after P2Y1/12 blockade is the only valid target for **MRS 2211** validation.

Module 2: The "Ghost Effect" (Off-Target Toxicity)

User Question: "I treated P2Y13 Knockout (KO) cells with **MRS 2211**, and I still see an effect. Is my KO failed?"

Technical Insight: Not necessarily. Recent literature (e.g., Madry et al., Neuron 2018) has shown that **MRS 2211** can exert effects in P2Y13-deficient systems, particularly in microglia and immune cells. This implies an off-target mechanism, potentially unrelated to purinergic signaling (chemotoxicity or interference with other GPCRs).

Troubleshooting Guide: The "Delta" Analysis

Never rely on a "Vehicle vs. Treated" comparison in Wild-Type (WT) cells alone. You must calculate the "Delta of Effect."

Group	Treatment	Outcome	Interpretation
WT Cells	Vehicle	100% (Baseline)	Reference
WT Cells	MRS 2211	40%	Potential P2Y13 blockade
KO Cells	Vehicle	100%	Reference
KO Cells	MRS 2211	95-100%	VALID: Drug is specific.
KO Cells	MRS 2211	40-60%	INVALID: Effect is off-target toxicity.

Actionable Step: If you observe the "Invalid" pattern, titrate down **MRS 2211**. The off-target effects are often dose-dependent. Try 1 μM or 3 μM instead of 10 μM .

Module 3: Chemical Integrity & Dosing

User Question: "My stock solution precipitated, or my results are inconsistent between batches."

Technical Insight: **MRS 2211** is a disodium salt.^[3] While soluble in water, its stability in aqueous solution is lower than in DMSO. Furthermore, the "selectivity window" is strictly concentration-dependent.

Solubility & Handling Table

Parameter	Specification	Best Practice
MW	474.66 g/mol	Always check batch-specific MW (hydration varies).[3]
Solubility (Water)	~33 mg/mL (70 mM)	Good for immediate use. Filter sterilize (0.22 µm).
Solubility (DMSO)	~100 mM	Recommended for Stock. Store aliquots at -20°C.
Stability	Light Sensitive	Protect from light. Use opaque tubes.
Max Effective Dose	10 µM (In Vitro)	Do not exceed 10 µM. Above this, P2Y12 blockade begins.

Pathway Visualization: P2Y13 Signaling Context

Understanding the downstream effectors helps select the right readout (e.g., RhoA vs. cAMP).

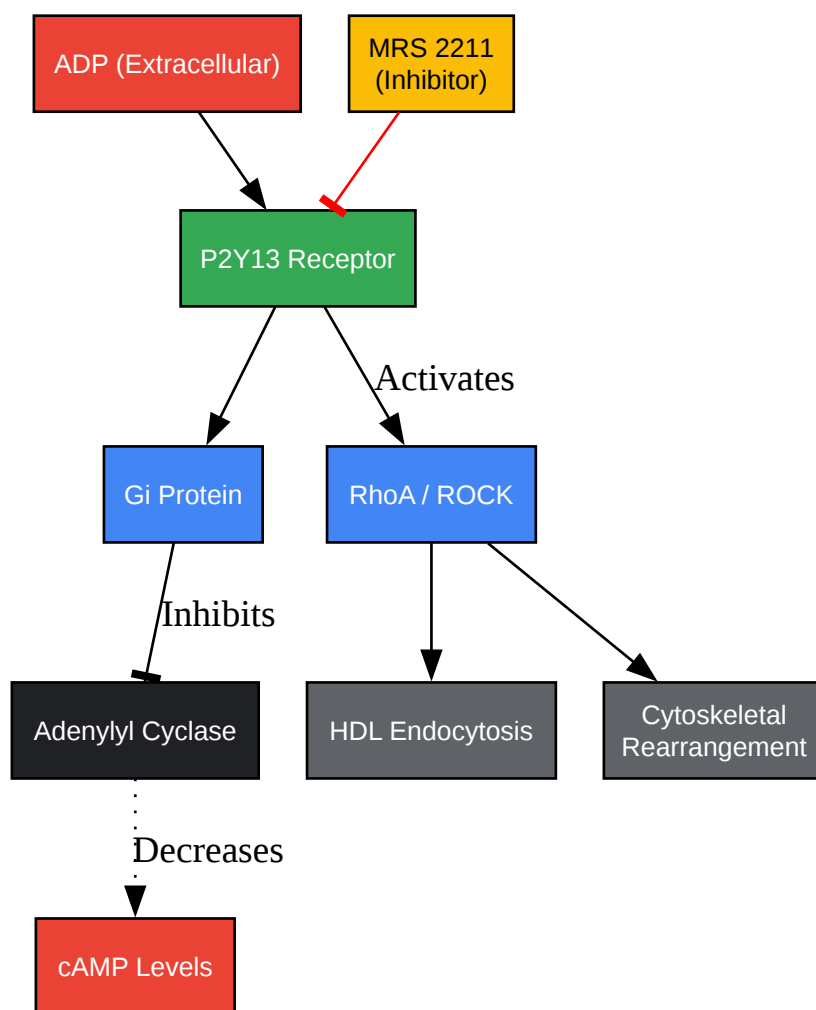

[Click to download full resolution via product page](#)

Caption: P2Y13 signaling bifurcates into Gi (cAMP reduction) and RhoA activation. **MRS 2211** blocks both arms.

FAQs: Rapid Response

Q: Can I use **MRS 2211** in vivo? A: Yes, but with extreme caution regarding dosing. Common doses are 1–3 mg/kg (i.v.) or up to 10 mg/kg (i.p.). However, at >3 mg/kg, you risk blocking platelet P2Y1/P2Y12, causing bleeding phenotypes unrelated to P2Y13. Always use a P2Y13 KO mouse as a control group.

Q: Is there a better antagonist? A: Currently, **MRS 2211** is the standard tool compound. MRS 2603 is another option, but it shares similar structural limitations. The most robust "antagonist" is the genetic knockout.

Q: Why does my calcium assay show no effect? A: P2Y13 is Gi-coupled.[4] It does not primarily mobilize intracellular calcium (unlike Gq-coupled P2Y1). If you are using a Fluo-4 assay, you are likely measuring P2Y1 activity. To measure P2Y13, you should use a cAMP HTRF assay (looking for inhibition of Forskolin-induced cAMP) or a RhoA activation assay.

References

- Kim, Y. C., et al. (2005). Synthesis of pyridoxal phosphate derivatives with antagonist activity at the P2Y13 receptor. *Biochemical Pharmacology*.
- Marteau, F., et al. (2003). Pharmacological characterization of the human P2Y13 receptor. *Molecular Pharmacology*.
- Madry, C., et al. (2018). Microglial Ramification, Surveillance, and Interleukin-1 β Release Are Regulated by the Two-Pore Domain K⁺ Channel THIK-1. *Neuron*. (Demonstrates off-target effects of **MRS 2211** in KO models).
- Tocris Bioscience. **MRS 2211** Product Datasheet & Solubility.
- MedChemExpress. **MRS 2211** Sodium Hydrate Technical Data.

Need Custom Synthesis?

BenchChem offers custom synthesis for rare earth carbides and specific isotopic labeling.

Email: info@benchchem.com or [Request Quote Online](#).

Sources

- [1. researchgate.net \[researchgate.net\]](https://www.researchgate.net)
- [2. Pharmacological characterization of P2Y receptor subtypes – an update - PMC \[pmc.ncbi.nlm.nih.gov\]](https://pubmed.ncbi.nlm.nih.gov/)
- [3. rndsystems.com \[rndsystems.com\]](https://www.rndsystems.com)
- [4. P2RY13 Exacerbates Intestinal Inflammation by Damaging the Intestinal Mucosal Barrier via Activating IL-6/STAT3 Pathway \[ijbs.com\]](https://www.ijbs.com)

- To cite this document: BenchChem. [Technical Support Center: MRS 2211 Validation & Control]. BenchChem, [2026]. [Online PDF]. Available at: [<https://www.benchchem.com/product/b1489678/docs#technical-support-center-mrs-2211-validation-control>]

Disclaimer & Data Validity:

The information provided in this document is for Research Use Only (RUO) and is strictly not intended for diagnostic or therapeutic procedures. While BenchChem strives to provide accurate protocols, we make no warranties, express or implied, regarding the fitness of this product for every specific experimental setup.

Technical Support: The protocols provided are for reference purposes. Unsure if this reagent suits your experiment?

Need Industrial/Bulk Grade? [Request Custom Synthesis Quote](#)

BenchChem

Our mission is to be the trusted global source of essential and advanced chemicals, empowering scientists and researchers to drive progress in science and industry.

Contact

Address: 3281 E Guasti Rd
Ontario, CA 91761, United States
Phone: (601) 213-4426
Email: info@benchchem.com

[Contact our Ph.D. Support Team for a compatibility check](#)