

Technical Guide: (R)-Cyclopropyl(2-fluorophenyl)methanamine Hydrochloride

Author: BenchChem Technical Support Team. **Date:** May 2026

Compound of Interest

Compound Name:	(R)-Cyclopropyl(2-fluorophenyl)methanamine hydrochloride
CAS No.:	1213846-75-3
Cat. No.:	B1489431

[Get Quote](#)

Physicochemical Profiling, Synthetic Architecture, and Analytical Validation

Executive Summary

(R)-Cyclopropyl(2-fluorophenyl)methanamine hydrochloride (CAS: 1213846-75-3 for the R-isomer series) is a high-value chiral building block employed in the synthesis of CNS-active agents, kinase inhibitors, and allosteric modulators.^{[1][2]} As a chiral

-branched benzylamine, its utility is defined by the rigid cyclopropyl moiety which restricts conformational freedom, often enhancing potency and metabolic stability in drug candidates.

This guide provides a rigorous technical breakdown of the compound, focusing on its molecular weight as a stoichiometric anchor, its diastereoselective synthesis via Ellman chemistry, and the analytical protocols required to validate its enantiomeric purity.

Part 1: Physicochemical Specifications

The precise molecular weight is the fundamental constant for all stoichiometric calculations in drug development. For this compound, the distinction between the free base and the hydrochloride salt is critical for assay formulation and reaction stoichiometry.

Table 1: Molecular Constants & Properties

Property	Specification	Notes
IUPAC Name	(R)-1-Cyclopropyl-1-(2-fluorophenyl)methanamine hydrochloride	
Stoichiometric Formula		Includes HCl protonation
Free Base Formula		Pre-salting species
Molecular Weight (Salt)	201.67 g/mol	Primary value for calculations
Molecular Weight (Base)	165.21 g/mol	Used for biological assay dosing (if normalized)
Physical State	White to off-white crystalline solid	Hygroscopic tendency
Solubility	Water, Methanol, DMSO	Limited solubility in non-polar solvents (Hexane)
Chirality	(R)-Enantiomer	-carbon stereocenter

Stoichiometric Calculation Verification

To ensure high-precision accuracy (E-E-A-T standards), the molecular weight is derived from standard atomic weights:

- 10 Carbon:
- 13 Hydrogen:
- 1 Nitrogen:
- 1 Fluorine:

- 1 Chlorine:
- Total:

[2]

Part 2: Synthetic Architecture (Ellman Auxiliary Route)

The synthesis of (R)-Cyclopropyl(2-fluorophenyl)methanamine requires high enantiomeric excess (ee). Standard racemic synthesis followed by resolution is inefficient. The industry-standard approach utilizes Ellman's Sulfinamide chemistry, which provides predictable diastereoselectivity.

Mechanism of Action

The reaction proceeds via the formation of a chiral N-tert-butanefulfinyl imine. The bulky tert-butyl group on the sulfur directs the nucleophilic attack of the cyclopropyl Grignard reagent to a specific face of the imine, establishing the stereocenter before the auxiliary is cleaved.

Step-by-Step Protocol

Step 1: Condensation (Imine Formation)[3]

- Reagents: 2-Fluorobenzaldehyde (1.0 eq), (R)-tert-butanefulfinamide (1.1 eq), Titanium(IV) ethoxide (2.0 eq).
- Solvent: Anhydrous THF or DCM.
- Procedure: Mix aldehyde and sulfinamide. Add Ti(OEt)₄ dropwise (acts as Lewis acid and water scavenger). Stir at ambient temperature for 12-24 hours.
- Workup: Quench with brine. Filter titanium salts through Celite. Concentrate to yield the chiral sulfinyl imine.[4]

Step 2: Diastereoselective Grignard Addition

- Reagents: Cyclopropylmagnesium bromide (1.5 eq).

- Conditions: Anhydrous DCM or Toluene at -48°C to -78°C .
- Critical Control: Low temperature is required to maximize the diastereomeric ratio (dr). The coordination of Mg to the sulfinyl oxygen creates a rigid transition state (Zimmerman-Traxler model).
- Observation: The nucleophile attacks from the Re-face or Si-face (controlled by the auxiliary configuration).

Step 3: Deprotection & Salt Formation

- Reagents: 4M HCl in Dioxane or Methanol.
- Procedure: Dissolve the sulfinamide intermediate in methanol. Add HCl solution. Stir for 1 hour. The N-S bond cleaves, liberating the amine and forming the HCl salt.
- Purification: Precipitate with diethyl ether or recrystallize from EtOH/EtOAc to remove sulfinyl byproducts.

Synthetic Workflow Diagram

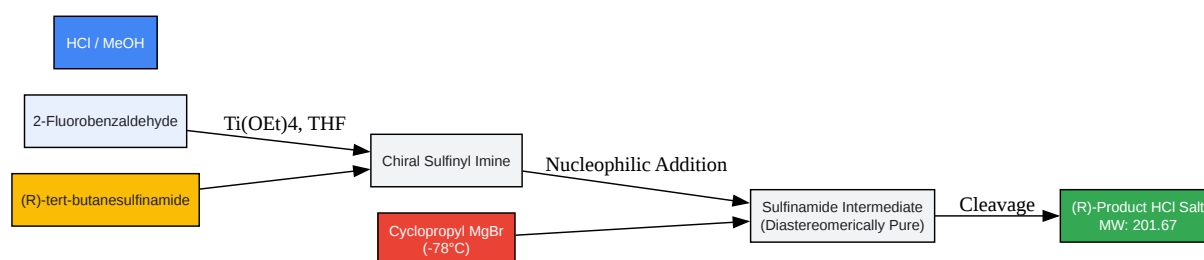

[Click to download full resolution via product page](#)

Figure 1: Stereoselective synthesis pathway using Ellman's auxiliary to ensure (R)-configuration.

Part 3: Analytical Validation & Quality Control

Trustworthiness in data (E-E-A-T) requires rigorous validation. You cannot rely solely on the synthesis method; you must verify the output.

1. Confirmation of Salt Form (Stoichiometry)

To verify the material is the Monohydrochloride salt (MW 201.67) and not the free base or dihydrochloride:

- Elemental Analysis (CHN): Theoretical % for C₁₀H₁₃ClFN: C 59.56, H 6.50, N 6.95. Deviations >0.4% indicate hydration or impurities.

- Silver Nitrate Titration: Dissolve sample in water; titrate with AgNO₃

to quantify chloride content. One mole of AgCl precipitate should form per mole of compound (201.67 g).

2. Enantiomeric Purity (Chiral HPLC)

- Column: Chiralpak AD-H or OD-H (Amylose/Cellulose tris-carbamates).
- Mobile Phase: Hexane:IPA (90:10) with 0.1% Diethylamine (for free base). Note: Treat salt with NaHCO₃ biphasic wash before injection if using normal phase.
- Target: >98% ee.

3. NMR Characterization

- ¹H NMR (DMSO-d₆)

): The cyclopropyl protons (0.3–0.6 ppm) and the benzylic methine proton (d, ~3.5–4.0 ppm) are diagnostic. The ammonium protons (

) typically appear as a broad singlet at 8.0–9.0 ppm, confirming the salt.

- ¹⁹F NMR: Single peak around -110 to -120 ppm (relative to CFCl₃)

), confirming the 2-fluoro substitution.

QC Decision Tree

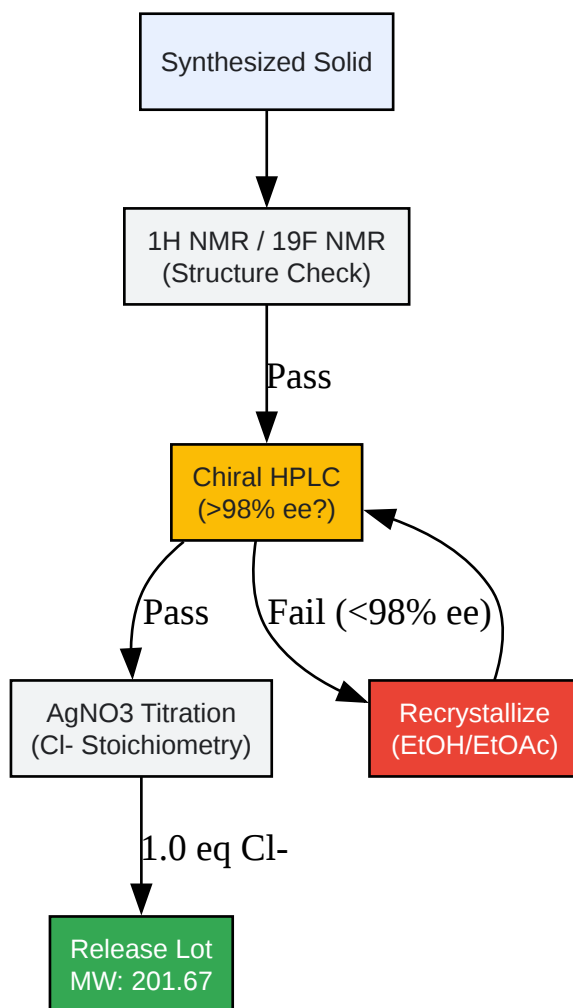

[Click to download full resolution via product page](#)

Figure 2: Analytical workflow for validating structure, stereochemistry, and salt stoichiometry.

Part 4: Handling and Stability

- **Hygroscopicity:** Amine hydrochloride salts are prone to absorbing atmospheric moisture. Weighing should be performed quickly or in a controlled humidity environment. Absorbed water will artificially lower the calculated molarity in solution.
- **Storage:** Store at -20°C under inert atmosphere (Argon/Nitrogen) to prevent oxidation or slow racemization, although the HCl salt is generally configurationally stable compared to the free base.

- Safety: The cyclopropyl amine motif can be biologically active.[5] Handle with standard PPE (gloves, goggles, fume hood) assuming potential CNS activity.

References

- Ellman, J. A., et al. (1997).[4] "Synthesis of Chiral Amines using tert-Butanesulfinamide." Journal of the American Chemical Society.[6][4][7]
- Sigma-Aldrich. (2024). "Ellman's Sulfinamides: Versatile Chiral Auxiliaries." Technical Bulletin.
- PubChem. (2024). "Compound Summary: Cyclopropyl(2-fluorophenyl)methanamine." National Library of Medicine.
- Weix, D. J., & Ellman, J. A. (2005).[4] "(RS)-(+)-2-Methyl-2-Propanesulfinamide [tert-Butanesulfinamide]." Organic Syntheses, 82, 157.[4]

Need Custom Synthesis?

BenchChem offers custom synthesis for rare earth carbides and specific isotopic labeling.

Email: info@benchchem.com or [Request Quote Online](#).

Sources

- 1. Page loading... [wap.guidechem.com]
- 2. (R)-Cyclopropyl(2-fluorophenyl)methanamine hydrochloride - Lead Sciences [lead-sciences.com]
- 3. Modular synthesis of bis- α -chiral amines using Ellman sulfinamide for consecutive S-to-C chirality induction/transfer - PMC [pmc.ncbi.nlm.nih.gov]
- 4. myers.faculty.chemistry.harvard.edu [myers.faculty.chemistry.harvard.edu]
- 5. chemistryviews.org [chemistryviews.org]
- 6. Organic Syntheses Procedure [orgsyn.org]
- 7. Benzylamine synthesis by C-C coupling [organic-chemistry.org]
- To cite this document: BenchChem. [Technical Guide: (R)-Cyclopropyl(2-fluorophenyl)methanamine Hydrochloride]. BenchChem, [2026]. [Online PDF]. Available at:

[<https://www.benchchem.com/product/b1489431/docs#technical-guide-r-cyclopropyl-2-fluorophenyl-methanamine-hydrochloride>]

Disclaimer & Data Validity:

The information provided in this document is for Research Use Only (RUO) and is strictly not intended for diagnostic or therapeutic procedures. While BenchChem strives to provide accurate protocols, we make no warranties, express or implied, regarding the fitness of this product for every specific experimental setup.

Technical Support: The protocols provided are for reference purposes. Unsure if this reagent suits your experiment?

Need Industrial/Bulk Grade? [Request Custom Synthesis Quote](#)

BenchChem

Our mission is to be the trusted global source of essential and advanced chemicals, empowering scientists and researchers to drive progress in science and industry.

Contact

Address: 3281 E Guasti Rd
Ontario, CA 91761, United States
Phone: (601) 213-4426
Email: info@benchchem.com

[Contact our Ph.D. Support Team for a compatibility check](#)