

Reagents for peptide coupling with electron-deficient amines

Author: BenchChem Technical Support Team. **Date:** May 2026

Compound of Interest

Compound Name: *3-Amino-1-(3,3-difluoropiperidin-1-yl)propan-1-one*

CAS No.: 1889795-44-1

Cat. No.: B1488479

[Get Quote](#)

Application Notes and Protocols

Topic: Advanced Reagents and Strategies for Peptide Coupling with Electron-Deficient Amines

Audience: Researchers, scientists, and drug development professionals.

Introduction: Overcoming the Challenge of Low Nucleophilicity

The formation of an amide bond is the cornerstone of peptide synthesis.[1][2] This reaction involves the nucleophilic attack of an amine on an activated carboxylic acid.[3][4] While standard coupling protocols are highly efficient for typical aliphatic amines found in proteinogenic amino acids, their efficacy plummets when confronting electron-deficient amines. These substrates, which include anilines bearing electron-withdrawing groups, certain heterocyclic amines, and N-methylated amino acids, present a significant synthetic hurdle due to their inherently low nucleophilicity and basicity.[5][6][7][8]

Attempting to force these reactions with standard conditions often leads to sluggish or incomplete conversions, necessitating harsh conditions that promote side reactions, most notably racemization of the activated amino acid.[5][9] This guide, written from the perspective of a senior application scientist, provides an in-depth exploration of the modern reagents and field-proven protocols designed to overcome these challenges, ensuring high yields and preservation of stereochemical integrity.

The Mechanistic Hurdle of Electron-Deficient Amines

The core problem lies in the reduced ability of the lone pair of electrons on the amine's nitrogen to participate in a nucleophilic attack. Electron-withdrawing substituents delocalize this electron density, rendering the amine a "poor" nucleophile. Consequently, the activated carboxylic acid intermediate must be exceptionally reactive to facilitate the coupling. This demand for high reactivity must be carefully balanced against the risk of side reactions.

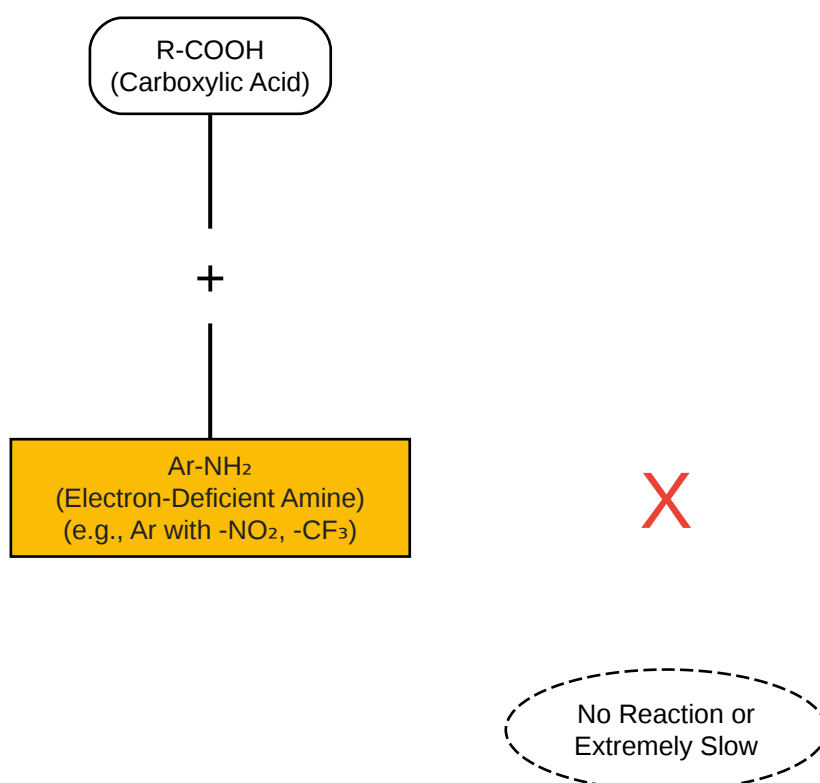

Figure 1: The Challenge of Low Nucleophilicity

[Click to download full resolution via product page](#)

Caption: Figure 1: The Challenge of Low Nucleophilicity.

A Modern Arsenal of Coupling Reagents

To address the acylation of poorly nucleophilic amines, several classes of highly efficient coupling reagents have been developed. These reagents generate exceptionally reactive intermediates, enabling bond formation where traditional methods like DCC/HOBt fail.[5][10]

Third-Generation Uronium/Guanidinium Salts: The Power of Oxyma and HOAt

Uronium- and guanidinium-type reagents are among the most popular and effective coupling reagents.[3][11] Their mechanism involves the formation of a highly reactive active ester. For electron-deficient amines, the choice of the leaving group in this active ester is critical.

- HATU and HCTU: Reagents based on 1-hydroxy-7-azabenzotriazole (HOAt) and its chlorinated analog (Cl-HOBt), such as HATU and HCTU respectively, generate active esters that are significantly more reactive than their HOBt-based counterparts (HBTU, TBTU).[10][11][12] The nitrogen atom in the pyridine ring of HOAt provides an "assisted basicity" effect, accelerating the aminolysis step. HATU is particularly effective for coupling N-methylated amino acids.[8]
- COMU: A standout third-generation reagent, COMU incorporates ethyl 2-cyano-2-(hydroxyimino)acetate (OxymaPure) as the leaving group.[4][12][13] COMU is considered safer than benzotriazole-based reagents, as it avoids potentially explosive intermediates.[11][13] Mechanistically, it exists in the more reactive uronium form and generates a highly reactive Oxyma active ester.[10] A key advantage is that its byproducts are water-soluble, greatly simplifying purification, especially in solution-phase synthesis.[12][13] Due to its high reactivity, COMU is exceptionally efficient for difficult couplings and requires only one equivalent of base for optimal performance.[10][13]

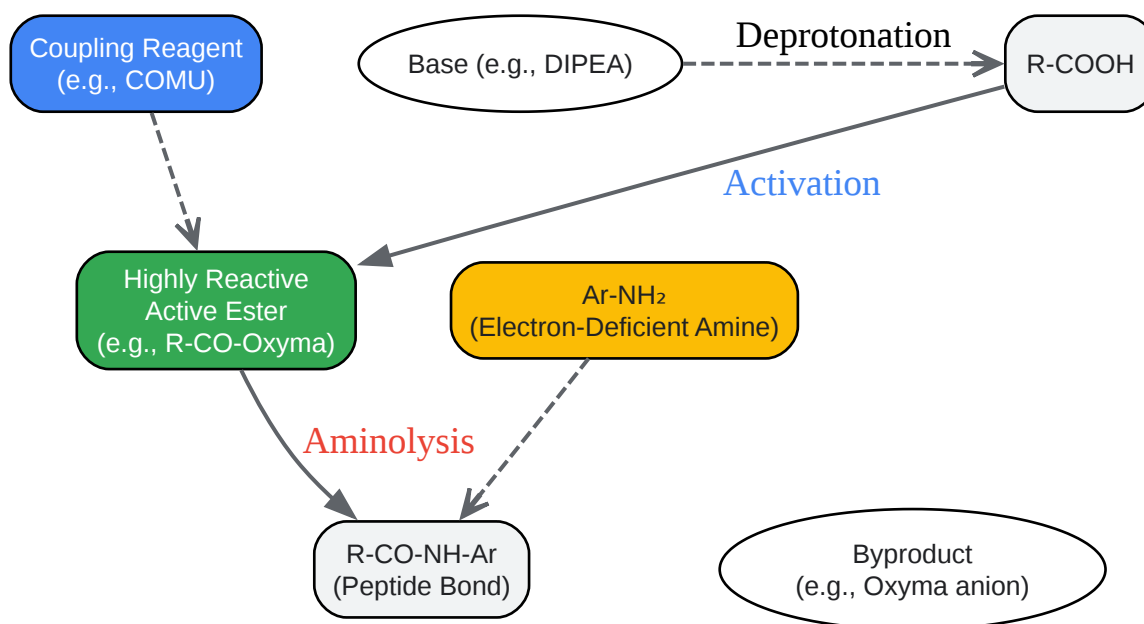

Figure 2: General Activation & Coupling Pathway

[Click to download full resolution via product page](#)

Caption: Figure 2: General Activation & Coupling Pathway.

Phosponium Salts: Eliminating Guanidinylation Risk

Phosponium-based reagents like PyBOP, PyAOP, and PyClock operate via a similar mechanism to uronium salts, forming active esters.^{[11][14]} Their primary advantage is the complete absence of reactivity towards the amine component.^{[11][14]} Uronium/guanidinium reagents, if used in excess relative to the carboxylic acid, can react with the free amine to form an undesired guanidinium cap, terminating peptide chain elongation.^{[10][11][14]} Since phosponium salts do not cause this side reaction, they can be used in excess to drive difficult couplings to completion, making them ideal for cyclization reactions or fragment condensations where precise stoichiometry is critical.^{[12][14]}

- PyAOP: The HOAt-based phosponium salt, is considered one of the most reactive reagents in this class.^{[11][14]}
- PyClock: The 6-Cl-HOBt-based analog, offers a good compromise between the high reactivity of PyAOP and the lower cost of PyBOP.^[14]

Acyl Fluoride Precursors: The Ultimate Solution for Steric Hindrance

For the most challenging substrates, particularly those that are both electron-deficient and sterically hindered, in situ formation of acyl fluorides provides a powerful alternative.^[6] Reagents such as TFFH (Tetramethylfluoroformamidinium hexafluorophosphate) and the related BTFFH convert carboxylic acids into their corresponding acyl fluorides. These intermediates are highly reactive yet surprisingly stable and less prone to racemization than their acyl chloride counterparts.^[6] The subsequent coupling often requires elevated temperatures to proceed efficiently but can succeed where all other methods fail.^[6]

Comparative Analysis of Key Reagents

Reagent	Class	Leaving Group	Key Advantages	Potential Drawbacks	Primary Application for ED-Amines
HATU	Guanidinium	HOAt	High reactivity, low racemization, effective for N-methyl amino acids. [8][11]	Contains potentially explosive HOAt moiety; risk of guanidinylation if used in excess. [11][12]	Moderately difficult couplings, including N-methylated residues.
COMU	Uronium	OxymaPure	Extremely high reactivity, superior safety profile (non-explosive), water-soluble byproducts. [12][13]	Higher cost than older reagents.	High-efficiency coupling for a broad range of difficult substrates. [13]
PyAOP	Phosphonium	HOAt	High reactivity, no risk of amine capping (guanidinylation), suitable for use in excess. [10][11][14]	High cost; contains HOAt moiety.	Fragment coupling, cyclization, or when excess reagent is needed to drive reaction.
BTFFH	Fluoroformamidinium	Fluoride	Forms highly reactive acyl fluoride;	Requires higher temperatures	"Last resort" for couplings that fail with

effective for extremely hindered and unreactive substrates.[6] for coupling; reagent can be moisture-sensitive. all other methods.[6]

Detailed Application Protocols

Protocol 1: High-Efficiency Coupling of an Electron-Deficient Amine using COMU

This protocol describes a general procedure for the solution-phase coupling of a protected amino acid to an aniline derivative.

Materials:

- Fmoc-protected amino acid (1.0 equiv)
- Electron-deficient amine (e.g., 4-nitroaniline) (1.1 equiv)
- COMU (1.1 equiv)[13]
- N,N-Diisopropylethylamine (DIPEA) (2.0 equiv)
- Anhydrous N,N-Dimethylformamide (DMF)

Procedure:

- **Reactant Preparation:** In a clean, dry, nitrogen-flushed flask, dissolve the Fmoc-protected amino acid (1.0 equiv) and COMU (1.1 equiv) in anhydrous DMF to a concentration of approximately 0.2 M.
- **Activation:** Add DIPEA (2.0 equiv) to the solution. Stir the mixture at room temperature. A color change to yellow or orange is often observed upon activation.[13] Allow the pre-activation to proceed for 5-10 minutes.

- **Coupling:** Add a solution of the electron-deficient amine (1.1 equiv) in a minimal amount of DMF to the activated mixture.
- **Reaction Monitoring:** Stir the reaction at room temperature. Monitor the progress by TLC or LC-MS. For difficult couplings, the reaction may require 2-12 hours for completion.
- **Work-up:** Once the reaction is complete, dilute the mixture with ethyl acetate. Wash the organic layer sequentially with 5% aqueous citric acid, saturated aqueous NaHCO₃, and brine.
- **Purification:** Dry the organic layer over anhydrous Na₂SO₄, filter, and concentrate under reduced pressure. The water-soluble byproducts of COMU and DIPEA salts are largely removed during the aqueous washes.^{[12][13]} Purify the crude product by flash column chromatography.

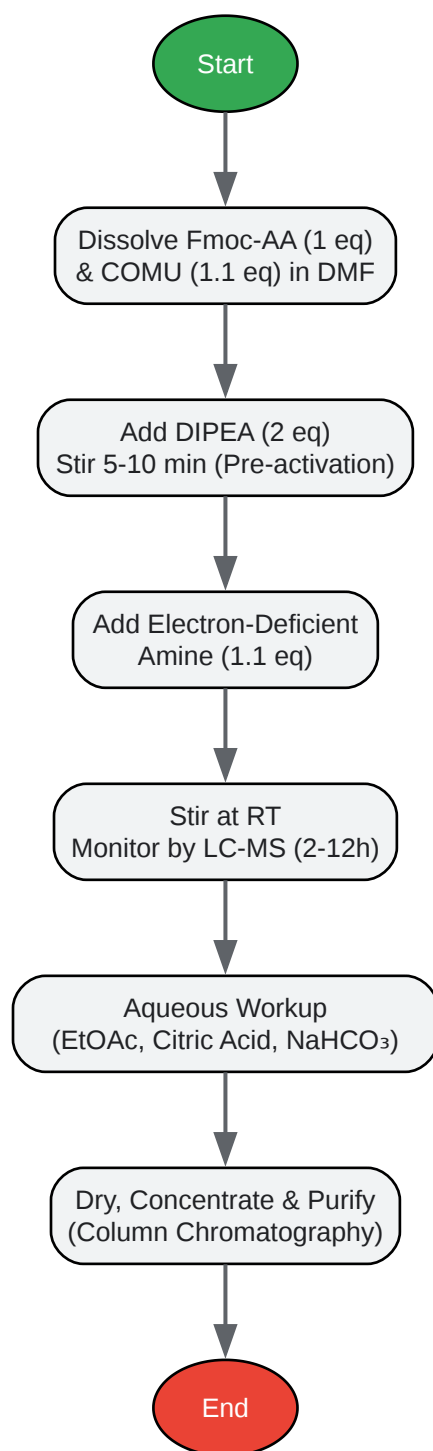

Figure 3: COMU Experimental Workflow

[Click to download full resolution via product page](#)

Caption: Figure 3: COMU Experimental Workflow.

Protocol 2: Coupling of a Sterically Hindered, Electron-Deficient Amine via an Acyl Fluoride (BTFFH Method)

This protocol is adapted for substrates where even powerful uronium salts fail.[6]

Materials:

- Sterically hindered carboxylic acid (1.0 equiv)
- Sterically hindered/electron-deficient amine (1.2 equiv)
- BTFFH (1.5 equiv)
- N,N-Diisopropylethylamine (DIPEA) (3.0 equiv)
- Anhydrous Acetonitrile (MeCN)

Procedure:

- **Reactant Preparation:** In a clean, dry, screw-cap vial flushed with nitrogen, combine the carboxylic acid (1.0 equiv) and BTFFH (1.5 equiv).
- **Acyl Fluoride Formation:** Add anhydrous MeCN to dissolve the solids (approx. 0.1 M), followed by DIPEA (1.5 equiv). Stir the mixture at room temperature for 30 minutes to form the acyl fluoride intermediate.
- **Coupling:** Add the amine (1.2 equiv) followed by the remaining portion of DIPEA (1.5 equiv).
- **Heating:** Securely cap the vial and heat the reaction mixture to 60-80 °C. Caution: Ensure the vial is properly sealed and shielded.
- **Reaction Monitoring:** Monitor the reaction by LC-MS until the starting material is consumed (typically 4-24 hours).
- **Work-up and Purification:** Cool the reaction to room temperature. Concentrate the solvent under reduced pressure. Partition the residue between ethyl acetate and water. Wash the organic layer with dilute acid and base as described in Protocol 1. Dry, concentrate, and purify the product by column chromatography.

Troubleshooting

- Low Yield/Incomplete Reaction:
 - Ensure all reagents and solvents are anhydrous. Water will quench the activated intermediates.
 - For phosphonium reagents, consider using a slight excess (1.2-1.5 equiv) to drive the reaction.[\[14\]](#)
 - If using COMU/HATU fails, switch to the acyl fluoride protocol (BTFFH) and increase the temperature.[\[6\]](#)
- Racemization Detected:
 - Minimize the pre-activation time.[\[8\]](#)
 - Use a weaker, non-nucleophilic base like 2,4,6-collidine in place of DIPEA, especially during fragment coupling.[\[11\]](#)
 - Run the reaction at a lower temperature if possible, though this may not be feasible for electron-deficient amines.
- Guanidinylation Side Product Observed (with Uronium Reagents):
 - Use a slight excess of the carboxylic acid relative to the coupling reagent. A 1.0:0.95 ratio of acid to reagent is often recommended.[\[12\]](#)
 - Alternatively, switch to a phosphonium reagent like PyAOP or PyCloCk, which cannot form this byproduct.[\[11\]](#)[\[14\]](#)

Conclusion

The successful acylation of electron-deficient amines is a critical capability in modern drug discovery and chemical biology. While challenging, the use of advanced coupling reagents has transformed this area. Third-generation uronium salts, particularly COMU, offer an outstanding combination of reactivity, safety, and convenience for a wide range of difficult substrates. For cases defined by extreme steric hindrance or low reactivity, phosphonium salts and in situ acyl

fluoride formation provide robust and reliable solutions. By understanding the underlying mechanisms and selecting the appropriate reagent and protocol, researchers can confidently and efficiently synthesize complex peptides and amide-containing molecules.

References

- Choosing the Right Coupling Reagent for Peptides: A Twenty-Five-Year Journey. Organic Process Research & Development - ACS Publications. [\[Link\]](#)
- Optimizing Peptide Coupling: Key Techniques. CordenPharma. [\[Link\]](#)
- Coupling Reagents. Aapptec Peptides. [\[Link\]](#)
- Peptide Coupling Reagents, More than a Letter Soup. Chemical Reviews. [\[Link\]](#)
- Synthesis of amide derivatives for electron deficient amines and functionalized carboxylic acids using EDC and DMAP and a catalytic amount of HOBT as the coupling reagents. PMC. [\[Link\]](#)
- COMU: A third generation of uronium-type coupling reagents. Luxembourg Bio Technologies. [\[Link\]](#)
- A protocol for amide bond formation with electron deficient amines and sterically hindered substrates. Organic & Biomolecular Chemistry (RSC Publishing). [\[Link\]](#)
- Convenient Synthesis of N-Methylamino Acids Compatible with Fmoc Solid-Phase Peptide Synthesis. The Journal of Organic Chemistry - ACS Publications. [\[Link\]](#)
- Phosphonium salts as peptide coupling reagents.
- Challenges and Achievements of Peptide Synthesis in Aqueous and Micellar Media. PMC. [\[Link\]](#)
- Synthesis of N-substituted peptide amides.
- Engineering of a Peptide α -N-Methyltransferase to Methylate Non-Proteinogenic Amino Acids. PMC. [\[Link\]](#)

- Greening the synthesis of peptide therapeutics: an industrial perspective. RSC Publishing. [\[Link\]](#)
- PyClock, the phosphonium salt derived from 6-Cl-HOBt. Luxembourg Bio Technologies. [\[Link\]](#)
- Addressing sustainability challenges in peptide synthesis with flow chemistry and machine learning. ChemRxiv. [\[Link\]](#)
- Synthesis of N-methylated cyclic peptides. ResearchGate. [\[Link\]](#)
- Peptide synthesis. Wikipedia. [\[Link\]](#)

Need Custom Synthesis?

BenchChem offers custom synthesis for rare earth carbides and specific isotopic labeling.

Email: info@benchchem.com or [Request Quote Online](#).

Sources

- [1. WO1990010009A1 - Phosphonium salts as peptide coupling reagents - Google Patents \[patents.google.com\]](#)
- [2. Peptide synthesis - Wikipedia \[en.wikipedia.org\]](#)
- [3. jpt.com \[jpt.com\]](#)
- [4. people.uniurb.it \[people.uniurb.it\]](#)
- [5. Synthesis of amide derivatives for electron deficient amines and functionalized carboxylic acids using EDC and DMAP and a catalytic amount of HOBt as the coupling reagents - PMC \[pmc.ncbi.nlm.nih.gov\]](#)
- [6. A protocol for amide bond formation with electron deficient amines and sterically hindered substrates - Organic & Biomolecular Chemistry \(RSC Publishing\) DOI:10.1039/C5OB02129D \[pubs.rsc.org\]](#)
- [7. pubs.acs.org \[pubs.acs.org\]](#)
- [8. merckmillipore.com \[merckmillipore.com\]](#)

- [9. Challenges and Achievements of Peptide Synthesis in Aqueous and Micellar Media - PMC \[pmc.ncbi.nlm.nih.gov\]](#)
- [10. peptide.com \[peptide.com\]](#)
- [11. bachem.com \[bachem.com\]](#)
- [12. pubs.acs.org \[pubs.acs.org\]](#)
- [13. luxembourg-bio.com \[luxembourg-bio.com\]](#)
- [14. luxembourg-bio.com \[luxembourg-bio.com\]](#)
- To cite this document: BenchChem. [Reagents for peptide coupling with electron-deficient amines]. BenchChem, [2026]. [Online PDF]. Available at: [\[https://www.benchchem.com/product/b1488479/docs#reagents-for-peptide-coupling-with-electron-deficient-amines\]](https://www.benchchem.com/product/b1488479/docs#reagents-for-peptide-coupling-with-electron-deficient-amines)

Disclaimer & Data Validity:

The information provided in this document is for Research Use Only (RUO) and is strictly not intended for diagnostic or therapeutic procedures. While BenchChem strives to provide accurate protocols, we make no warranties, express or implied, regarding the fitness of this product for every specific experimental setup.

Technical Support: The protocols provided are for reference purposes. Unsure if this reagent suits your experiment?

Need Industrial/Bulk Grade? [Request Custom Synthesis Quote](#)

BenchChem

Our mission is to be the trusted global source of essential and advanced chemicals, empowering scientists and researchers to drive progress in science and industry.

Contact

Address: 3281 E Guasti Rd
Ontario, CA 91761, United States
Phone: (601) 213-4426
Email: info@benchchem.com

Contact our Ph.D. Support Team for a compatibility check