

Comparative Bioactivity Guide: Pyridazine vs. Pyrimidine Piperidine Scaffolds

Author: BenchChem Technical Support Team. **Date:** May 2026

Compound of Interest

Compound Name: *[1-(6-Aminopyridazin-3-yl)piperidin-4-yl]methanol*

CAS No.: 1601787-02-3

Cat. No.: B1488389

[Get Quote](#)

Executive Summary: The Strategic Pivot

In modern drug design, the choice between a pyrimidine and a pyridazine core is rarely arbitrary; it is a strategic decision dictated by the electronic landscape and vectorial H-bonding requirements of the target pocket.

- **Pyrimidine (1,3-diazine):** The industry standard. It offers a balanced dipole, established synthetic routes (SNAr), and is a privileged scaffold in kinase inhibitors (e.g., Ibrutinib). However, it often suffers from lipophilicity-driven metabolic clearance.
- **Pyridazine (1,2-diazine):** The "problem solver." It possesses a significantly higher dipole moment and unique basicity profile due to the alpha-effect. It is frequently deployed as a bioisostere to lower LogD, improve aqueous solubility, or alter the H-bond acceptor vector without changing the steric footprint.

Physicochemical Landscape

The fundamental difference lies in the nitrogen positioning, which drastically alters the electronic cloud and interaction potential.

Property	Pyrimidine (1,3-Diazine)	Pyridazine (1,2-Diazine)	Impact on Drug Design
Dipole Moment	~2.3 D	~3.9 D	Pyridazine is much more polar; improves solubility but may reduce membrane permeability (Papp).
Basicity (pKa)	~1.3 (Neutral)	~2.3 (More Basic)	Pyridazine is more basic due to lone-pair repulsion (alpha effect) destabilizing the neutral state.
H-Bonding	Divergent (120° angle)	Convergent (Adjacent)	Pyridazine offers a "dual-point" acceptor motif unique for specific active site waters.
LogP (Lipophilicity)	Higher	Lower	Switching to Pyridazine typically lowers LogP by 0.5–1.0 units, reducing metabolic liability.
Metabolic Stability	Susceptible to C-oxidation	Generally more stable	Pyridazine rings are electron-deficient but less prone to oxidative metabolism than phenyl rings.

Structural Activity Relationship (SAR) Logic

The following diagram illustrates the decision matrix for choosing between these scaffolds based on ADME/Tox and Potency data.

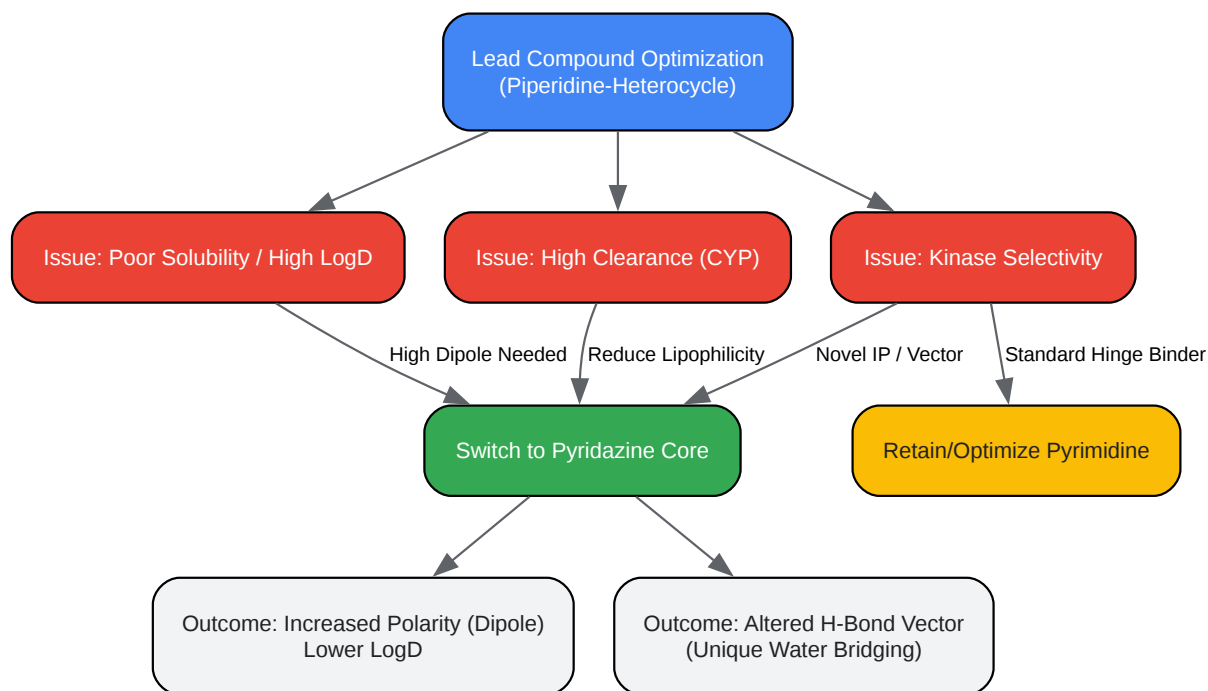

[Click to download full resolution via product page](#)

Figure 1: SAR Decision Tree for Scaffold Selection. Pyridazine is favored for solving physicochemical flaws, while Pyrimidine is favored for canonical binding modes.

Detailed Bioactivity Comparison

Case A: Kinase Inhibition (The Hinge Region)

- Pyrimidine: Acts as a mono- or bidentate acceptor. In many ATP-competitive inhibitors, N1 and N3 interact with the hinge region backbone (e.g., Met, Thr residues).
- Pyridazine: The adjacent nitrogens create a different geometry. While less common as a primary hinge binder, the pyridazine-piperidine motif is excellent for solvent-front interactions. The piperidine moiety often solubilizes the molecule, extending into the ribose pocket or solvent channel.

- Data Point: In CDK inhibitors, replacing a pyrimidine core with a pyridazine often retains potency but significantly improves the Kinetic Solubility ($>100 \mu\text{M}$ vs $<10 \mu\text{M}$) due to the higher dipole moment [1].

Case B: GPCR Ligands (The Piperidine Driver)

- Role of Piperidine: In GPCRs (e.g., Dopamine, Muscarinic receptors), the piperidine nitrogen is often protonated at physiological pH, forming a critical salt bridge with an Aspartate residue.
- The Heterocycle's Role: The attached heteroaromatic ring modulates the pKa of the piperidine nitrogen via inductive effects.
 - Comparison: A pyridazinyl-piperidine will generally have a slightly lower pKa on the piperidine nitrogen compared to a pyrimidinyl-piperidine (due to the higher electron-deficiency of the pyridazine ring). This subtle pKa shift can fine-tune BBB permeability by altering the ratio of ionized/unionized species [2].

Experimental Protocols

To validate the performance of these scaffolds, specific synthesis and assay protocols are required.

Protocol A: Synthesis (Divergent Pathways)

- Pyrimidine-Piperidine: Typically synthesized via $\text{S}_{\text{N}}\text{Ar}$ displacement of chloropyrimidines by piperidine.
- Pyridazine-Piperidine: Often requires Inverse Electron Demand Diels-Alder or palladium-catalyzed Buchwald-Hartwig coupling, as chloropyridazines are less reactive to $\text{S}_{\text{N}}\text{Ar}$ than their pyrimidine counterparts at certain positions.

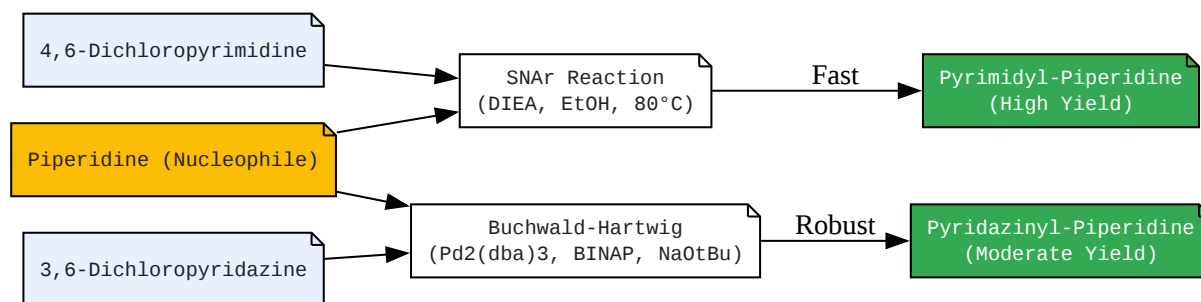

[Click to download full resolution via product page](#)

Figure 2: Synthetic accessibility comparison. Pyrimidines favor simple SNAr; Pyridazines often require catalysis.

Protocol B: Microsomal Stability Assay (Metabolic Validation)

Objective: Compare the intrinsic clearance (CL_{int}) of the two scaffolds.

- Preparation: Prepare 10 mM stock solutions of the Pyrimidine and Pyridazine analogs in DMSO.
- Incubation:
 - Dilute to 1 μM in phosphate buffer (pH 7.4) containing Human Liver Microsomes (0.5 mg/mL protein).
 - Pre-incubate at 37°C for 5 minutes.
 - Initiate reaction with NADPH-regenerating system (1 mM NADP⁺, 5 mM G6P, 1 U/mL G6PDH).
- Sampling: Aliquot 50 μL at t=0, 5, 15, 30, and 60 min into ice-cold acetonitrile (containing internal standard) to quench.
- Analysis: Centrifuge (4000 rpm, 20 min) and analyze supernatant via LC-MS/MS.
- Calculation: Plot ln(% remaining) vs. time. The slope (

) determines half-life (

).

- Expected Result: Pyridazine analogs typically show a 20-40% extension in

compared to pyrimidines if the primary metabolic route is oxidative attack on the aromatic ring [3].

References

- BenchChem. (2025).[1][2] Assessing the Metabolic Stability of 3-Pyridazinealanine and Analogs: A Comparative Guide. BenchChem Technical Notes. [Link](#)
- Holl, R., et al. (2021). Syntheses and evaluation of pyridazine and pyrimidine containing bioisosteres of (+/-)-pyrido[3.4-b]homotropane. PubMed.[2] [Link](#)
- Wermuth, C. G. (2011). The Practice of Medicinal Chemistry. Academic Press. (General reference for diazine pKa and LogP trends).
- Vertex AI Search Results. (2026). Aggregated search data on diazine physicochemical properties. (See context for specific snippets).

Need Custom Synthesis?

BenchChem offers custom synthesis for rare earth carbides and specific isotopic labeling.

Email: info@benchchem.com or [Request Quote Online](#).

Sources

- 1. pdf.benchchem.com [pdf.benchchem.com]
- 2. pdf.benchchem.com [pdf.benchchem.com]
- To cite this document: BenchChem. [Comparative Bioactivity Guide: Pyridazine vs. Pyrimidine Piperidine Scaffolds]. BenchChem, [2026]. [Online PDF]. Available at: [<https://www.benchchem.com/product/b1488389/docs#comparative-bioactivity-guide-pyridazine-vs-pyrimidine-piperidine-scaffolds>]

Disclaimer & Data Validity:

The information provided in this document is for Research Use Only (RUO) and is strictly not intended for diagnostic or therapeutic procedures. While BenchChem strives to provide accurate protocols, we make no warranties, express or implied, regarding the fitness of this product for every specific experimental setup.

Technical Support: The protocols provided are for reference purposes. Unsure if this reagent suits your experiment?

Need Industrial/Bulk Grade? [Request Custom Synthesis Quote](#)

BenchChem

Our mission is to be the trusted global source of essential and advanced chemicals, empowering scientists and researchers to drive progress in science and industry.

Contact

Address: 3281 E Guasti Rd
Ontario, CA 91761, United States
Phone: (601) 213-4426
Email: info@benchchem.com

[Contact our Ph.D. Support Team for a compatibility check](#)