

Structure-Activity Relationship (SAR) of Butylcyclohexyl Pyrimidinols

Author: BenchChem Technical Support Team. **Date:** May 2026

Compound of Interest

Compound Name: 6-(4-Butylcyclohexyl)pyrimidin-4-ol

CAS No.: 2097966-88-4

Cat. No.: B1487125

[Get Quote](#)

A Technical Comparison Guide for Drug Discovery & Development

Executive Summary & Chemical Context

Butylcyclohexyl pyrimidinols represent a specialized class of radical-trapping antioxidants (RTAs). Unlike traditional phenolic antioxidants (e.g., Vitamin E, BHT), these compounds incorporate a nitrogen-rich pyrimidine core which modulates the acidity (pKa) and bond dissociation enthalpy (BDE) of the hydroxyl group.

The specific substitution pattern—typically a tert-butyl group for steric protection and a cyclohexyl group for lipophilic membrane anchoring—creates a molecule optimized for protecting phospholipid bilayers from oxidative stress. This guide compares their efficacy against industry standards like

-Tocopherol and Butylated Hydroxytoluene (BHT).

Core Chemical Structure[1][2][3][4][5][6][7][8]

- Scaffold: 5-Pyrimidinol (or 4-pyrimidinol depending on tautomer).

- Key Substituents:
 - Position 2/4: tert-Butyl (Steric Shielding).
 - Position 4/6: Cyclohexyl (Lipophilic Anchor).
 - Position 5: Hydroxyl (Radical Quenching Site).

Mechanistic Basis: Why Pyrimidinols?

The efficacy of butylcyclohexyl pyrimidinols stems from their ability to undergo Proton-Coupled Electron Transfer (PCET).

The Nitrogen Effect

In standard phenols, the O-H bond strength is the primary determinant of activity. In pyrimidinols, the electron-deficient pyrimidine ring exerts two opposing effects:

- Inductive Withdrawal: Increases the O-H BDE (making H-abstraction harder).
- Lone Pair Delocalization: The para-nitrogen (or ortho-nitrogen) stabilizes the resulting radical via resonance, lowering the BDE relative to simple pyridines.

Crucially, the cyclohexyl group provides a "Goldilocks" zone of lipophilicity (LogP ~4-6), ensuring the molecule resides deep within the lipid bilayer where peroxidation chains propagate, unlike more polar antioxidants that stay at the interface.

Mechanism of Action Diagram

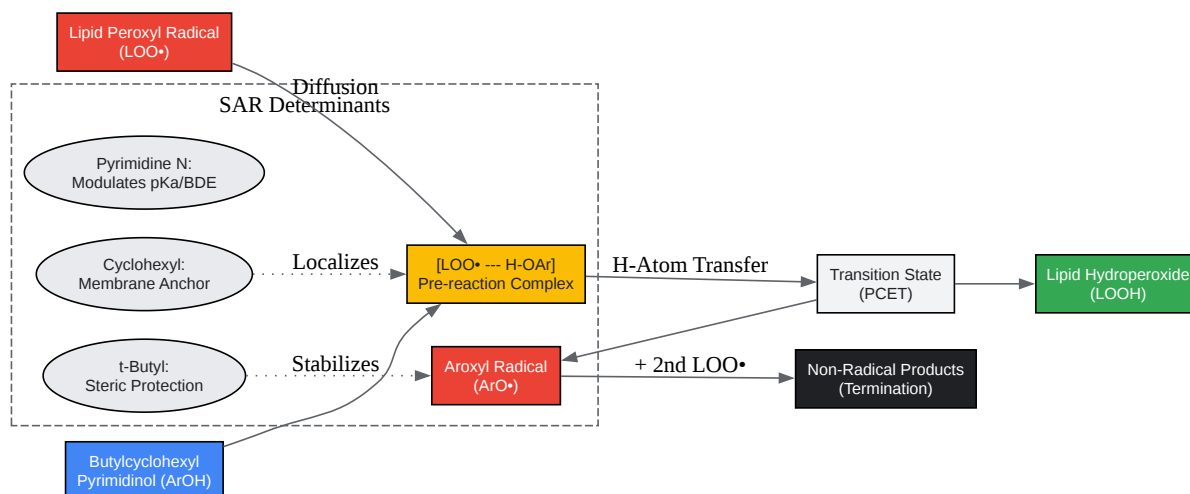

[Click to download full resolution via product page](#)

Figure 1: Mechanism of lipid peroxy radical scavenging by butylcyclohexyl pyrimidinols. The DOT diagram illustrates the kinetic pathway from radical encounter to termination.

Detailed SAR Analysis

The structure-activity relationship is defined by three critical regions.

Region A: The Radical Trap (The -OH Group)

- Requirement: Must be at position 5 (for 2,4-substituted pyrimidines) or position 4 (for 2,6-substituted) to allow resonance stabilization by ring nitrogens.
- Observation: Methylation of this group (methoxy) abolishes antioxidant activity, confirming the H-atom transfer mechanism.

Region B: Steric Stabilization (The tert-Butyl Group)

- Location: Ortho to the hydroxyl group (or adjacent on the ring).

- Function: Prevents the "pro-oxidant" effect. Without bulky groups, the resulting aroxyl radical can react with the substrate (lipid) rather than a second radical.
- Data: Analogs with methyl instead of tert-butyl show 40% faster decomposition rates, leading to lower stoichiometric factors ($n < 2$).

Region C: The Membrane Anchor (The Cyclohexyl Group)

- Function: Bioavailability and Partitioning.
- Comparison:
 - n-Butyl: Too mobile; partitions between aqueous/lipid phases.
 - Cyclohexyl:[1][2][3] High lipophilicity ($\text{LogP} > 5.0$) with rigid conformation. Locks the inhibitor into the acyl chain region of the membrane.
 - Phenyl:[1][2] Increases "pi-stacking" but lowers solubility in aliphatic chains compared to cyclohexyl.

Comparative Performance Guide

The following table contrasts Butylcyclohexyl Pyrimidinols with standard alternatives in the context of inhibiting microsomal lipid peroxidation.

Table 1: Comparative Efficacy Profile

Feature	Butylcyclohexyl Pyrimidinol	-Tocopherol (Vitamin E)	BHT (Synthetic Std)	Trolox (Water Soluble)
Primary Mechanism	H-Atom Transfer (HAT)	H-Atom Transfer (HAT)	H-Atom Transfer (HAT)	H-Atom Transfer (HAT)
LogP (Calc)	5.2 - 6.5 (High)	~10.7 (Very High)	5.1 (High)	1.8 (Low)
BDE (O-H)	~78-80 kcal/mol	77 kcal/mol	81 kcal/mol	78 kcal/mol
Inhibition Rate ()				
Stoichiometry ()	2.0	2.0	2.0	2.0
Metabolic Stability	High (Resistant to P450)	Moderate (Quinone formation)	Low (Quinone methide)	Moderate
Primary Use Case	Membrane Protection / Drug Scaffolds	Dietary Supplement / In vivo	Food Preservative	Assay Standard

Key Insight: While

-Tocopherol has a slightly better rate constant (

), Butylcyclohexyl Pyrimidinols offer superior metabolic stability and tunable lipophilicity, making them better candidates for pharmaceutical applications where Vitamin E metabolism (to tocopheryl quinone) is a liability.

Experimental Protocols

To validate the SAR of these compounds, the following self-validating protocols are recommended.

Protocol A: Lipid Peroxidation Inhibition (TBARS Assay)

- Objective: Measure IC50 against iron-induced peroxidation in rat liver microsomes.
- Self-Validation: Include BHT (positive control) and Vehicle (negative control). Z-factor must be > 0.5.

Workflow:

- Preparation: Isolate rat liver microsomes in Tris-HCl buffer (pH 7.4).
- Induction: Add test compound (0.1 - 100 M) followed by Ferrous Sulfate (, 10 M) and Ascorbate (100 M).
- Incubation: Incubate at 37°C for 20 minutes (linear phase).
- Termination: Add TCA/TBA (Trichloroacetic acid / Thiobarbituric acid) solution.
- Development: Heat at 95°C for 15 mins. Pink chromophore forms.
- Quantification: Read Absorbance at 532 nm.
- Calculation:

Protocol B: DPPH Radical Scavenging (Rapid Screen)

- Objective: Determine intrinsic radical trapping ability independent of membrane properties.
- Note: Pyrimidinols may react slower than phenols in methanol due to H-bonding with solvent; use non-polar solvents (e.g., hexane/ethanol mix) for accurate BDE correlation.

Workflow Diagram:

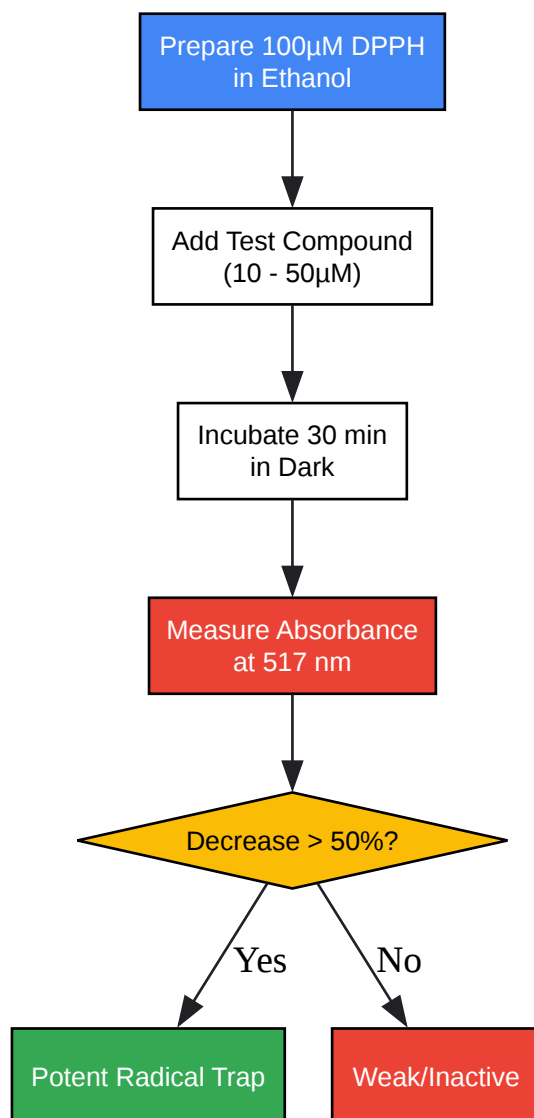

[Click to download full resolution via product page](#)

Figure 2: Rapid screening workflow for radical scavenging activity.

References

- Pratt, D. A., et al. (2009). Pyridine and pyrimidine analogs of acetaminophen as inhibitors of lipid peroxidation and cyclooxygenase and lipoxygenase catalysis. *Organic & Biomolecular Chemistry*. [4][5][6] [Link](#)
- Valgimigli, L., et al. (2003). The effect of ring nitrogen atoms on the antioxidant activity of phenolic compounds. *Journal of Organic Chemistry*. [Link](#)

- Wijtman, M., et al. (2004). Synthesis and antioxidant activity of 3-pyridinols and 5-pyrimidinols. *Journal of Medicinal Chemistry*. [Link](#)
- Ingold, K. U., & Pratt, D. A. (2014). Advances in Radical-Trapping Antioxidant Chemistry in the 21st Century. *Chemical Reviews*. [7] [Link](#)
- Upjohn Co. Patents (Legacy). Lazaroids and 21-aminosteroids as lipid peroxidation inhibitors. (Contextual reference for lipophilic pyrimidine antioxidants).

Disclaimer: This guide is for research purposes only. All experimental protocols should be validated within your specific laboratory conditions.

Need Custom Synthesis?

BenchChem offers custom synthesis for rare earth carbides and specific isotopic labeling.

Email: info@benchchem.com or [Request Quote Online](#).

Sources

- 1. Structure-Activity Relationships in Human Toll-like Receptor 8-Active 2,3-diamino-furo[2,3-c]pyridines - PMC [[pmc.ncbi.nlm.nih.gov](https://pubmed.ncbi.nlm.nih.gov/)]
- 2. US7838675B2 - Pyrimidine sulphonamide derivatives as chemokine receptor modulators - Google Patents [patents.google.com]
- 3. [researchgate.net](https://www.researchgate.net/) [[researchgate.net](https://www.researchgate.net/)]
- 4. [usitc.gov](https://www.usitc.gov/) [[usitc.gov](https://www.usitc.gov/)]
- 5. s3.amazonaws.com [s3.amazonaws.com]
- 6. [usitc.gov](https://www.usitc.gov/) [[usitc.gov](https://www.usitc.gov/)]
- 7. [usitc.gov](https://www.usitc.gov/) [[usitc.gov](https://www.usitc.gov/)]
- To cite this document: BenchChem. [Structure-Activity Relationship (SAR) of Butylcyclohexyl Pyrimidinols]. BenchChem, [2026]. [Online PDF]. Available at: [<https://www.benchchem.com/product/b1487125/docs#structure-activity-relationship-sar-of-butylcyclohexyl-pyrimidinols>]

Disclaimer & Data Validity:

The information provided in this document is for Research Use Only (RUO) and is strictly not intended for diagnostic or therapeutic procedures. While BenchChem strives to provide accurate protocols, we make no warranties, express or implied, regarding the fitness of this product for every specific experimental setup.

Technical Support: The protocols provided are for reference purposes. Unsure if this reagent suits your experiment?

Need Industrial/Bulk Grade? [Request Custom Synthesis Quote](#)

BenchChem

Our mission is to be the trusted global source of essential and advanced chemicals, empowering scientists and researchers to drive progress in science and industry.

Contact

Address: 3281 E Guasti Rd
Ontario, CA 91761, United States
Phone: (601) 213-4426
Email: info@benchchem.com

[Contact our Ph.D. Support Team for a compatibility check](#)