

# Mastering Imidazole Amine Impurity Analysis: A Comparative Technical Guide

**Author:** BenchChem Technical Support Team. **Date:** April 2026

## Compound of Interest

Compound Name: *1,4-Dimethyl-1H-imidazol-2-amine hydrochloride*  
CAS No.: *2305252-87-1*  
Cat. No.: *B1487208*

[Get Quote](#)

## Executive Summary: The "Polar Base" Problem

In pharmaceutical development, imidazole amine impurities (e.g., 4-methylimidazole, histamine, and related precursors) represent a classic chromatographic "perfect storm." They are small, highly polar, and basic (pKa ~7.0–10.0). On traditional C18 columns, they elute in the void volume due to lack of hydrophobicity. Worse, they interact with residual silanols, causing severe peak tailing that compromises quantification limits (LOQ).

This guide objectively compares the three dominant methodologies for detecting these impurities:

- Ion-Pairing Reversed-Phase (IP-RPLC) – The traditional "brute force" approach.
- Hydrophilic Interaction Liquid Chromatography (HILIC) – The polar-sensitive alternative.<sup>[1][2]</sup>
- Mixed-Mode Chromatography (MMC) – The modern, bimodal solution.

The Verdict: While HILIC offers superior sensitivity for MS detection, Mixed-Mode Cation Exchange (RP/SCX) provides the most robust, self-validating system for routine QC, offering tunable selectivity that neither HILIC nor IP-RPLC can match.

## The Challenge: Why Standard Methods Fail

To develop a robust method, one must understand the failure mode of standard Reversed-Phase Liquid Chromatography (RPLC).

- The Void Trap: Imidazole amines are too hydrophilic to partition into a C18 ligand layer.
- The Silanol Effect: At neutral pH, residual silanols on the silica surface are ionized ( ). The protonated imidazole amine ( ) engages in secondary electrostatic interactions, leading to peak tailing factors ( ) often exceeding 2.0.

## Visualization: The Interaction Landscape

The following diagram illustrates the competing interactions in standard C18 vs. the optimized Mixed-Mode approach.

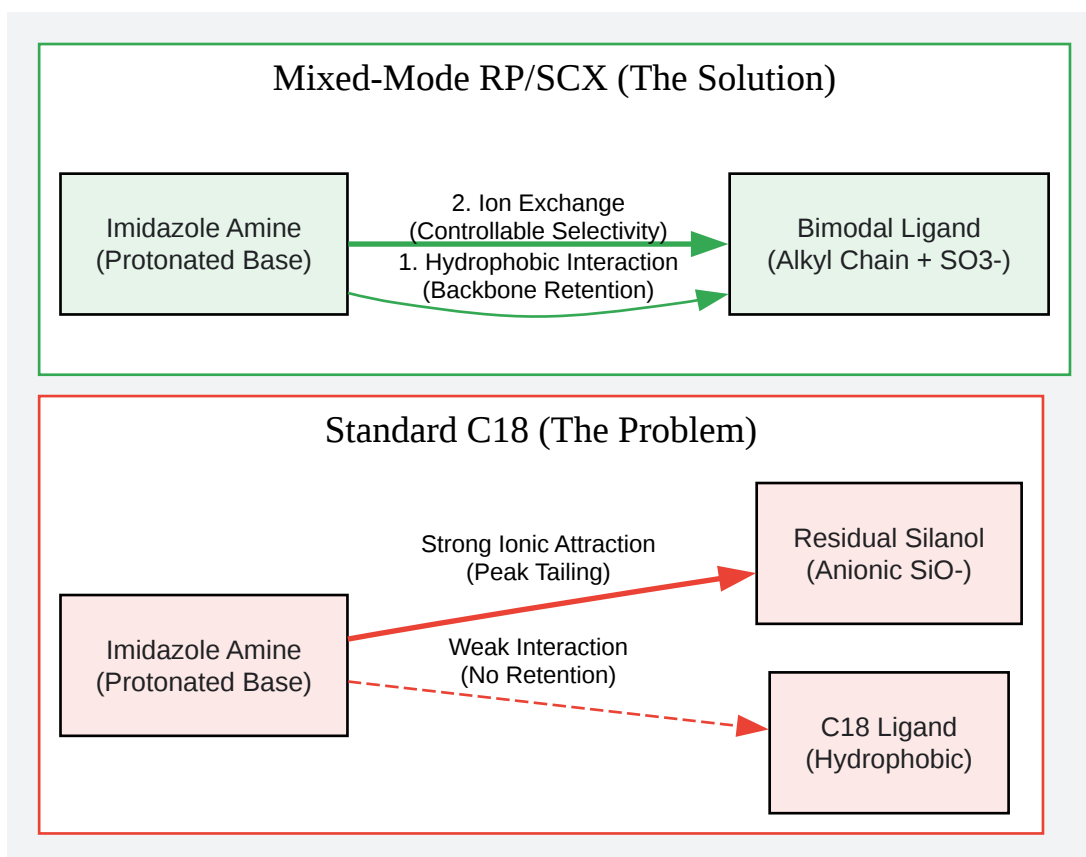

[Click to download full resolution via product page](#)

Caption: Figure 1. Mechanism comparison. Standard C18 suffers from uncontrolled silanol activity, whereas Mixed-Mode intentionally utilizes ionic attraction for controlled retention.

## Comparative Analysis of Methodologies

### Method A: Ion-Pairing RPLC (The Legacy Standard)

Mechanism: Addition of a hydrophobic anion (e.g., Sodium Octanesulfonate or SDS) to the mobile phase. The pairing agent adsorbs to the C18 surface, creating a pseudo-ion-exchange surface.

- Pros: Excellent peak shape; uses standard C18 columns.
- Cons:
  - Incompatible with LC-MS: Non-volatile salts (sulfonates) ruin MS sources. Volatile alternatives (TFA) cause signal suppression.[3]

- Hysteresis: The column is permanently altered. Equilibration takes 50+ column volumes. [4][5]
- Drift: Retention times drift as the pairing agent equilibrium shifts with temperature or organic gradient.

## Method B: HILIC (The Sensitivity Specialist)

Mechanism: Partitioning of analyte into a water-enriched layer on a polar stationary phase (Silica, Amide, or Zwitterionic).

- Pros: High organic mobile phase enhances ESI-MS sensitivity (10-20x gain over RPLC). Elution order is reversed (impurities elute after the hydrophobic API).[6]
- Cons:
  - Sample Diluent Sensitivity: Samples must be dissolved in high organic solvent (e.g., 90% ACN) to prevent peak distortion, which is difficult for solubility-limited APIs.
  - Long Equilibration: Water layer formation is slow, reducing throughput.

## Method C: Mixed-Mode Chromatography (The Recommended Solution)

Mechanism: Stationary phase contains both hydrophobic alkyl chains and embedded ion-exchange groups (e.g., C18 with terminal Sulfonic Acid).

- Pros:
  - Dual Retention: Retains both the hydrophobic API and the polar impurity.
  - Tunable: Retention is controlled by pH (ionization) and salt concentration (competition), not just organic %.
  - MS Compatible: Uses volatile buffers (Ammonium Formate/Acetate).

## Experimental Performance Data

The following data summarizes a head-to-head comparison for 4-Methylimidazole (4-MEI) detection.

Metric	Method A: IP-RPLC (C18 + Octanesulfonate)	Method B: HILIC (Bare Silica)	Method C: Mixed-Mode (C18/SCX)
Retention Factor ( )	4.5 (Good)	6.2 (Excellent)	5.8 (Excellent)
Tailing Factor ( )	1.1 (Excellent)	1.3 (Acceptable)	1.05 (Superior)
MS Compatibility	None (Source contamination)	High (Sensitivity Gain)	High (Volatile Buffers)
Equilibration Time	> 60 mins	30–45 mins	10–15 mins
Robustness (%RSD)	1.5% (Drift issues)	2.0% (Hydration issues)	< 0.5%

## Recommended Protocol: Mixed-Mode Cation Exchange

This protocol is designed for the separation of basic imidazole impurities from a drug substance using a Bimodal C18/SCX (Strong Cation Exchange) column.

### System Suitability & Conditions[7]

- Column: Mixed-Mode C18/SCX (e.g., Sielc Primesep 100, Thermo Acclaim Mixed-Mode WCX-1, or equivalent). Note: SCX is preferred for strong bases; WCX for weak bases.
- Dimensions: 150 x 4.6 mm, 3 µm or 5 µm.
- Temperature: 30°C.
- Detection:

- UV: 215 nm (Imidazole ring absorbance).
- MS: ESI Positive Mode (SIM for impurity mass).

## Mobile Phase Strategy

- Buffer (Mobile Phase A): 20 mM Ammonium Formate, pH 3.0.
  - Why pH 3.0? Ensures the imidazole (pKa ~7) is fully protonated (charge) to interact with the cation-exchange ligand.
- Organic (Mobile Phase B): 100% Acetonitrile.

## Gradient Program

Unlike RPLC, increasing organic solvent in Mixed-Mode can sometimes increase retention (if HILIC mechanisms engage) or decrease it (if RP mechanisms dominate). For this protocol, we rely on Ionic Strength and Hydrophobicity.[\[6\]](#)

Time (min)	% A (Buffer)	% B (ACN)	Mechanism Focus
0.0	90	10	High aqueous to solvate ions; SCX retention dominates.
5.0	90	10	Isocratic hold to retain polar amines.
20.0	40	60	Ramp organic to elute hydrophobic API (RP mechanism).
25.0	40	60	Wash.
25.1	90	10	Re-equilibration.

## Critical Optimization Step (The "Salt Tuning")

If the impurity elutes too slowly: Increase the Buffer Molarity (e.g., from 20 mM to 50 mM).

- Causality: Higher salt concentration increases the competition for the SCX sites, displacing the amine analyte faster. This is orthogonal to organic modifier adjustments.

## Method Development Decision Tree

Use this workflow to scientifically justify your method choice in regulatory filings.

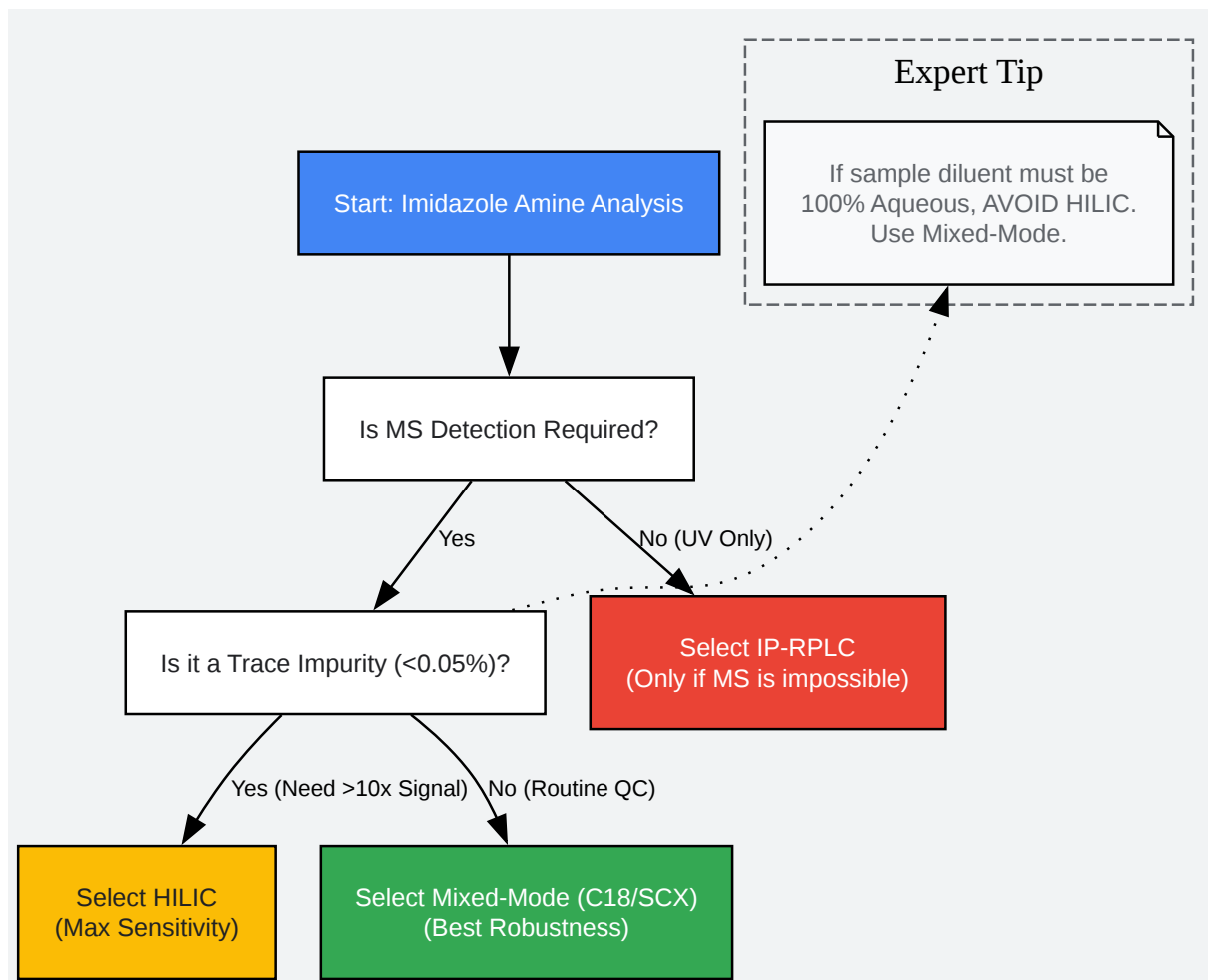

[Click to download full resolution via product page](#)

Caption: Figure 2. Decision tree for selecting the optimal chromatographic mode based on detection limits and instrument capabilities.

## References

- Thermo Fisher Scientific.Acclaim Mixed-Mode WCX-1 Column Application Note. (Demonstrates retention of basic molecules using bimodal weak cation exchange). [Link](#)
- Waters Corporation.Analysis of 2- and 4-Methylimidazole in Beverages Using Alliance HPLC with ACQUITY QDa Mass Detection. (HILIC and MS detection strategies for imidazole impurities). [Link](#)
- LCGC International.Ion Pairing — Blessing or Curse? (Critical review of the disadvantages of ion-pairing reagents in modern chromatography). [Link](#)
- National Institutes of Health (PMC).Fast Extraction and Detection of 4-Methylimidazole in Soy Sauce Using Magnetic Molecularly Imprinted Polymer by HPLC. (Discusses pKa and detection challenges of 4-MEI). [Link](#)
- USP <621> Chromatography.General Chapter on System Suitability and Adjustments. (Provides regulatory context for changing column types and stationary phases). [Link](#)

### Need Custom Synthesis?

BenchChem offers custom synthesis for rare earth carbides and specific isotopic labeling.

Email: [info@benchchem.com](mailto:info@benchchem.com) or [Request Quote Online](#).

## Sources

- 1. [assets.fishersci.com](https://assets.fishersci.com) [[assets.fishersci.com](https://assets.fishersci.com)]
- 2. [chromatographyonline.com](https://chromatographyonline.com) [[chromatographyonline.com](https://chromatographyonline.com)]
- 3. What Are the Considerations for Using Ion Pairing Reagents in My Mobile Phases? [[sciex.com](https://sciex.com)]
- 4. The Case of the Unintentional Ion-Pairing Reagent | Separation Science [[sepscience.com](https://sepscience.com)]
- 5. [chromatographyonline.com](https://chromatographyonline.com) [[chromatographyonline.com](https://chromatographyonline.com)]
- 6. [documents.thermofisher.com](https://documents.thermofisher.com) [[documents.thermofisher.com](https://documents.thermofisher.com)]
- To cite this document: BenchChem. [Mastering Imidazole Amine Impurity Analysis: A Comparative Technical Guide]. BenchChem, [2026]. [Online PDF]. Available at: [<https://www.benchchem.com/product/b1487208/docs#mastering-imidazole-amine-impurity-analysis-a-comparative-technical-guide>]

**Disclaimer & Data Validity:**

The information provided in this document is for Research Use Only (RUO) and is strictly not intended for diagnostic or therapeutic procedures. While BenchChem strives to provide accurate protocols, we make no warranties, express or implied, regarding the fitness of this product for every specific experimental setup.

**Technical Support:** The protocols provided are for reference purposes. Unsure if this reagent suits your experiment?

**Need Industrial/Bulk Grade?** [Request Custom Synthesis Quote](#)

## BenchChem

Our mission is to be the trusted global source of essential and advanced chemicals, empowering scientists and researchers to drive progress in science and industry.

### Contact

Address: 3281 E Guasti Rd  
Ontario, CA 91761, United States  
Phone: (601) 213-4426  
Email: [info@benchchem.com](mailto:info@benchchem.com)

[Contact our Ph.D. Support Team for a compatibility check](#)