

Comparative Guide: Cationic (DOTAP) vs. Anionic (DOPG) Liposomal Transfection Systems

Author: BenchChem Technical Support Team. **Date:** May 2026

Compound of Interest

Compound Name:	<i>Dioleoyl phosphatidylglycerole sodium salt</i>
CAS No.:	322647-40-5
Cat. No.:	B1487562

[Get Quote](#)

Executive Summary: The Charge Dilemma

In nucleic acid delivery, the choice between DOTAP (1,2-dioleoyl-3-trimethylammonium-propane) and DOPG (1,2-dioleoyl-sn-glycero-3-phospho-(1'-rac-glycerol)) represents a fundamental trade-off between transfection potency and biocompatibility.

- DOTAP (Cationic): The industry standard for in vitro transfection. It relies on strong electrostatic attraction to bind negatively charged nucleic acids, resulting in high uptake but significant cytotoxicity and serum instability.
- DOPG (Anionic): Historically considered a "helper" or structural lipid. It repels nucleic acids by default. However, when engineered into Anionic Lipoplexes (ALs) using divalent cation bridges (), it offers a low-toxicity alternative with superior serum stability, albeit with a narrower window of optimization.

This guide details the mechanistic differences, comparative performance data, and specific protocols for utilizing both systems.

Mechanistic Divergence

The primary differentiator is the mechanism of payload binding and cellular entry.

DOTAP: Electrostatic Saturation

DOTAP possesses a permanent positive charge (quaternary ammonium). It spontaneously collapses DNA/RNA into compact nanoparticles (lipoplexes) via electrostatic interaction. The net positive charge facilitates interaction with the proteoglycans on the anionic cell membrane, promoting endocytosis.

DOPG: Cationic Bridging

DOPG is anionic.^[1] To bind DNA, it requires a divalent cation bridge (typically Calcium,

or Magnesium,

). The cation neutralizes the repulsion between the phosphate backbone of the lipid and the nucleic acid, "gluing" them together.

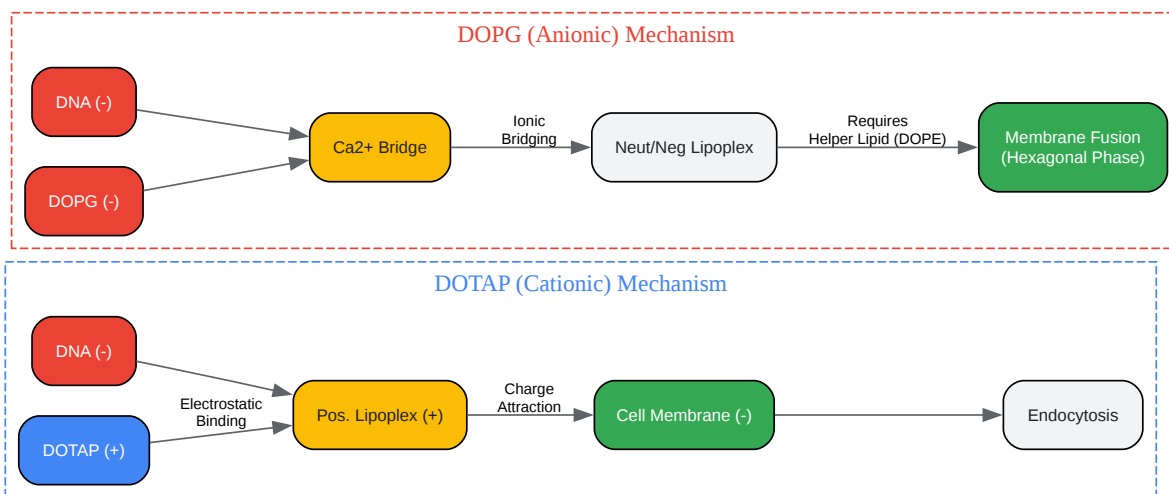

[Click to download full resolution via product page](#)

Figure 1: Mechanistic pathways. DOTAP utilizes direct electrostatic attraction, while DOPG requires Calcium bridging to overcome repulsive forces.

Comparative Performance Data

The following data summarizes typical performance metrics observed in mammalian cell lines (e.g., CHO-K1, HEK293).

Metric	DOTAP (Cationic)	DOPG (Anionic/Ca2+)
Zeta Potential	+30 mV to +60 mV	-20 mV to -50 mV (adjusts to ~0 with Ca2+)
Transfection Efficiency	High (Standard Reference)	Moderate (Can reach ~70-80% of DOTAP if optimized)
Cytotoxicity	High (Significant apoptosis >30 µg/mL)	Low (Minimal toxicity even at high lipid loads)
Serum Stability	Poor (Aggregates with serum proteins)	High (Resists protein corona formation)
In Vivo Circulation	Short (Rapid clearance by RES)	Long (Stealth properties)
Critical Reagent	Helper Lipid (DOPE/Cholesterol)	Divalent Cation ()

Key Insight: While DOTAP is the "sledgehammer" for getting DNA into cells in vitro, DOPG-based systems are superior for applications requiring low toxicity or prolonged circulation in vivo [1, 2].

Experimental Protocols

Protocol A: High-Efficiency DOTAP Liposomes

Best for: Hard-to-transfect cells where toxicity is a secondary concern.

Materials:

- DOTAP (Cl⁻ salt)
- DOPE (Helper lipid, essential for endosomal escape)
- Chloroform[2][3][4]
- HEPES Buffer (20mM, pH 7.4)[5]

Workflow:

- Lipid Mixing: Mix DOTAP and DOPE in a 1:1 molar ratio in chloroform.
- Film Formation: Evaporate solvent via rotary evaporator (40°C) to form a thin film.[4]
Desiccate for 2 hours.
- Hydration: Hydrate film with HEPES buffer to a final lipid concentration of 1 mg/mL. Vortex vigorously.
- Sizing: Extrude 11 times through a 100 nm polycarbonate membrane.
- Complexation: Mix Liposomes with DNA at an N/P ratio of 4:1 (Nitrogen in DOTAP : Phosphate in DNA). Incubate 20 mins at RT.

Protocol B: Low-Toxicity DOPG Anionic Lipoplexes

Best for: Sensitive cells (primary cultures) or in vivo studies.

Materials:

- DOPG (Na⁺ salt)[1][6]
- DOPE (Helper lipid, critical for fusion)
- Calcium Chloride () solution (500 mM stock)
- Plasmid DNA[1][6][7][8][9][10]

Workflow:

- Lipid Mixing: Mix DOPG and DOPE in a 17:83 molar ratio (DOPG:DOPE). Note: High DOPE content is critical for the inverted hexagonal phase transition required for fusion [1].
- Vesicle Formation: Prepare liposomes via thin-film hydration (as above) in sterile water.
- Calcium Activation:

- Prepare DNA in water.
- Add

to the DNA solution.^[7] Optimization is required: Titrate

to achieve a final concentration of 10–20 mM in the final well volume.
- Complexation: Add DOPG/DOPE liposomes to the DNA/

mixture. Incubate 20 mins at RT.
 - Critical Step: The order of addition matters. DNA +

then add Lipids.^{[1][6]}

Troubleshooting & Optimization Logic

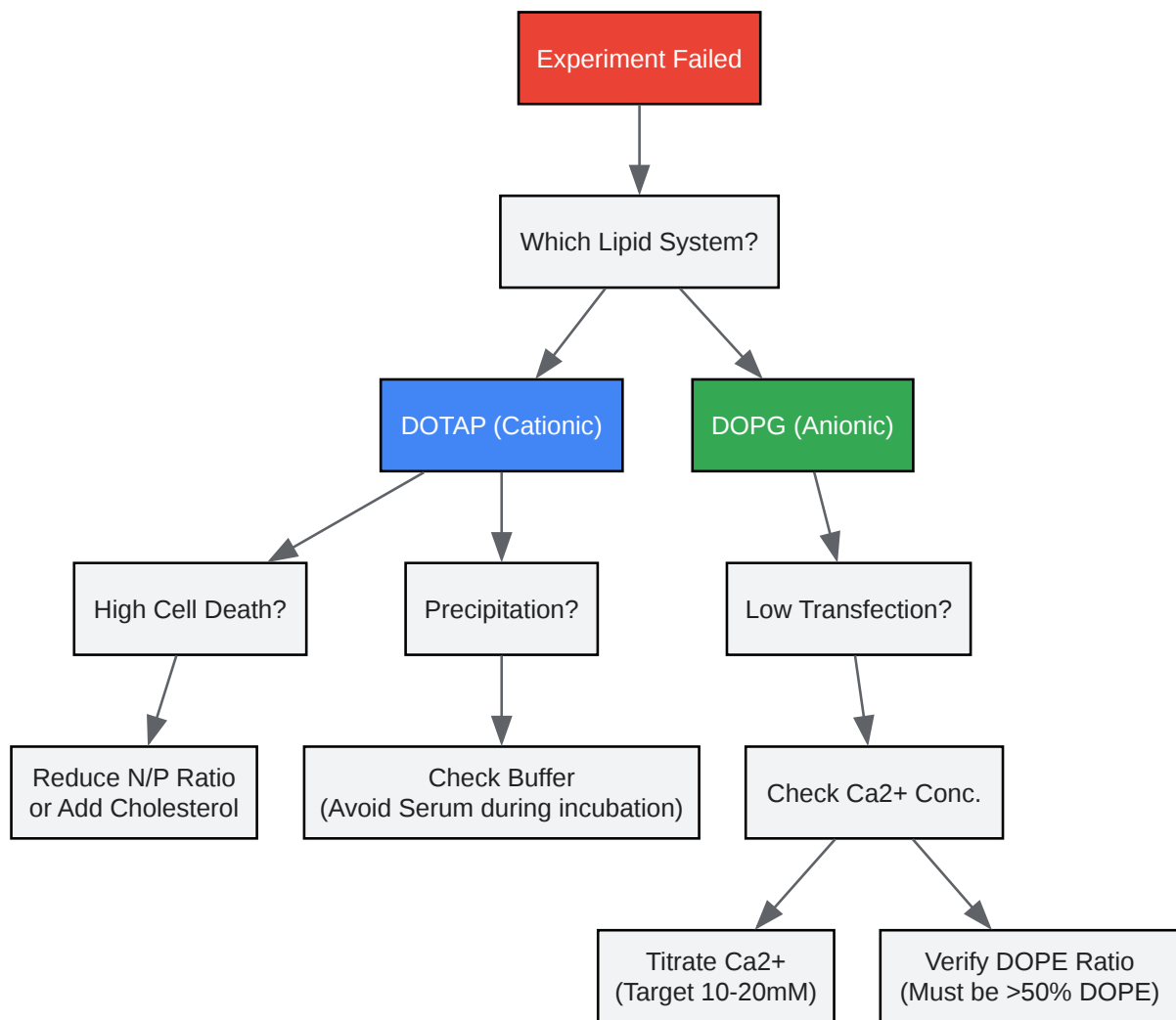

[Click to download full resolution via product page](#)

Figure 2: Decision tree for troubleshooting common transfection failures in cationic vs. anionic systems.

Critical Failure Points:

- Serum Interference (DOTAP): Cationic liposomes bind serum albumin immediately. Solution: Perform the initial 4-hour incubation in serum-free media (e.g., Opti-MEM).
- Calcium Overload (DOPG): Excess (>25mM) can cause cytotoxicity and precipitation of phosphate buffers. Solution: Use HEPES buffers and keep

between 10-20 mM [3].

- Phase Transition (DOPG): DOPG alone creates stable bilayers that do not fuse with cells. It must be mixed with DOPE (fusogenic lipid) to facilitate the transition to the hexagonal () phase upon endosomal acidification [4].

References

- Patil, S. D., Rhodes, D. G., & Burgess, D. J. (2004). Anionic liposomal delivery system for DNA transfection.[7] *The AAPS Journal*, 6(4), 1-10.[7] [Link](#)
- Simberg, D., et al. (2004). DOTAP (and other cationic lipids): chemistry, biophysics, and transfection. *Critical Reviews in Therapeutic Drug Carrier Systems*. [Link](#)
- Khosravi-Darani, K., et al. (2010). Calcium based non-viral gene delivery: an overview of methodology and applications.[7] *Acta Medica Iranica*. [Link](#)
- Avanti Polar Lipids. Preparation of Cationic Liposomes & Transfection of Cells. Technical Protocols. [Link](#)
- Li, Y., et al. (2023). Negatively charged phospholipids doped liposome delivery system for mRNA with high transfection efficiency and low cytotoxicity. *Asian Journal of Pharmaceutical Sciences*. [Link](#)

Need Custom Synthesis?

BenchChem offers custom synthesis for rare earth carbides and specific isotopic labeling.

Email: info@benchchem.com or [Request Quote Online](#).

Sources

- [1. Anionic liposomal delivery system for DNA transfection - PMC \[pmc.ncbi.nlm.nih.gov\]](#)
- [2. avantiresearch.com \[avantiresearch.com\]](#)
- [3. merckmillipore.com \[merckmillipore.com\]](#)
- [4. nanomedicinelab.com \[nanomedicinelab.com\]](#)

- [5. sigmaaldrich.com \[sigmaaldrich.com\]](https://sigmaaldrich.com)
- [6. scilit.com \[scilit.com\]](https://scilit.com)
- [7. dovepress.com \[dovepress.com\]](https://dovepress.com)
- [8. Ca\(2+\)-mediated anionic lipid-plasmid DNA lipoplexes. Electrochemical, structural, and biochemical studies - PubMed \[pubmed.ncbi.nlm.nih.gov\]](https://pubmed.ncbi.nlm.nih.gov)
- [9. pubs.acs.org \[pubs.acs.org\]](https://pubs.acs.org)
- [10. brieflands.com \[brieflands.com\]](https://brieflands.com)
- To cite this document: BenchChem. [Comparative Guide: Cationic (DOTAP) vs. Anionic (DOPG) Liposomal Transfection Systems]. BenchChem, [2026]. [Online PDF]. Available at: [<https://www.benchchem.com/product/b1487562/docs#comparative-guide-cationic-dotap-vs-anionic-dopg-liposomal-transfection-systems>]

Disclaimer & Data Validity:

The information provided in this document is for Research Use Only (RUO) and is strictly not intended for diagnostic or therapeutic procedures. While BenchChem strives to provide accurate protocols, we make no warranties, express or implied, regarding the fitness of this product for every specific experimental setup.

Technical Support: The protocols provided are for reference purposes. Unsure if this reagent suits your experiment?

Need Industrial/Bulk Grade? [Request Custom Synthesis Quote](#)

BenchChem

Our mission is to be the trusted global source of essential and advanced chemicals, empowering scientists and researchers to drive progress in science and industry.

Contact

Address: 3281 E Guasti Rd

Ontario, CA 91761, United States

Phone: (601) 213-4426

Email: info@benchchem.com

Contact our Ph.D. Support Team for a compatibility check