

Technical Support Center: Minimizing Homocoupling in Boronic Acid Synthesis

Author: BenchChem Technical Support Team. **Date:** May 2026

Compound of Interest

Compound Name: *T-Butyl-4'-bromobenzoate-2'-boronic acid*
Cat. No.: *B14853101*

[Get Quote](#)

Topic: Minimizing Homocoupling Side Reactions Audience: Medicinal Chemists, Process Chemists, and Drug Development Scientists Version: 2.4 (Current)

Introduction: The "Dimer" Problem

In the synthesis of aryl boronic acids and esters—critical intermediates for Suzuki-Miyaura coupling—the formation of the symmetric biaryl impurity (Ar-Ar, homocoupling) is the most persistent side reaction.

This guide addresses the two primary synthetic routes:

- Palladium-Catalyzed Borylation (Miyaura): Where oxidative homocoupling is driven by oxygen or catalyst disproportionation.
- Metal-Halogen Exchange (Lithiation): Where Wurtz-type coupling occurs due to thermal excursions or mixing inefficiencies.

Module 1: Palladium-Catalyzed (Miyaura) Borylation

The Core Issue: In the presence of oxygen or specific Pd(II) species, the intermediate arylpalladium species (

) can undergo disproportionation or oxidation to form

, which reductively eliminates to form the biaryl dimer (

) instead of the desired boronate.

Troubleshooting Guide: Pd-Catalyzed Protocols

Symptom	Probable Cause	Corrective Action
High Dimer (Ar-Ar) levels (>5%)	Dissolved Oxygen	Oxygen promotes the formation of peroxo-palladium species that accelerate homocoupling. Action: Switch from simple N ₂ flushing to subsurface sparging (bubbling inert gas through solvent) for 20 mins prior to catalyst addition.
Reaction stalls; Dimer increases over time	Catalyst Death (Pd Black)	Inactive Pd(0) aggregates (Pd black) can catalyze non-specific homocoupling. Action: Add Potassium Formate (1–2 mol%). It acts as a mild reducing agent to regenerate active Pd(0) without interfering with the borylation cycle.
Suzuki Coupling (Ar-Ar-Bpin)	Base too strong	Strong bases (e.g., ,) hydrolyze the newly formed BPin ester to the boronic acid in situ, which then cross-couples with remaining Ar-X. Action: Stick to KOAc (anhydrous). It is basic enough to activate but too weak to activate the product for Suzuki coupling.
Incomplete Conversion + Dimer	Ligand Sterics	Unhindered phosphines allow two Ar groups to coordinate to Pd. Action: Use bulky, electron-rich ligands like XPhos or

SPhos. These enforce a mono-ligation state, sterically crowding out the second aryl group required for homocoupling.

Visualizing the Mechanism

The following diagram illustrates the "Decision Point" within the catalytic cycle where the system diverges toward the desired boronate or the unwanted dimer.

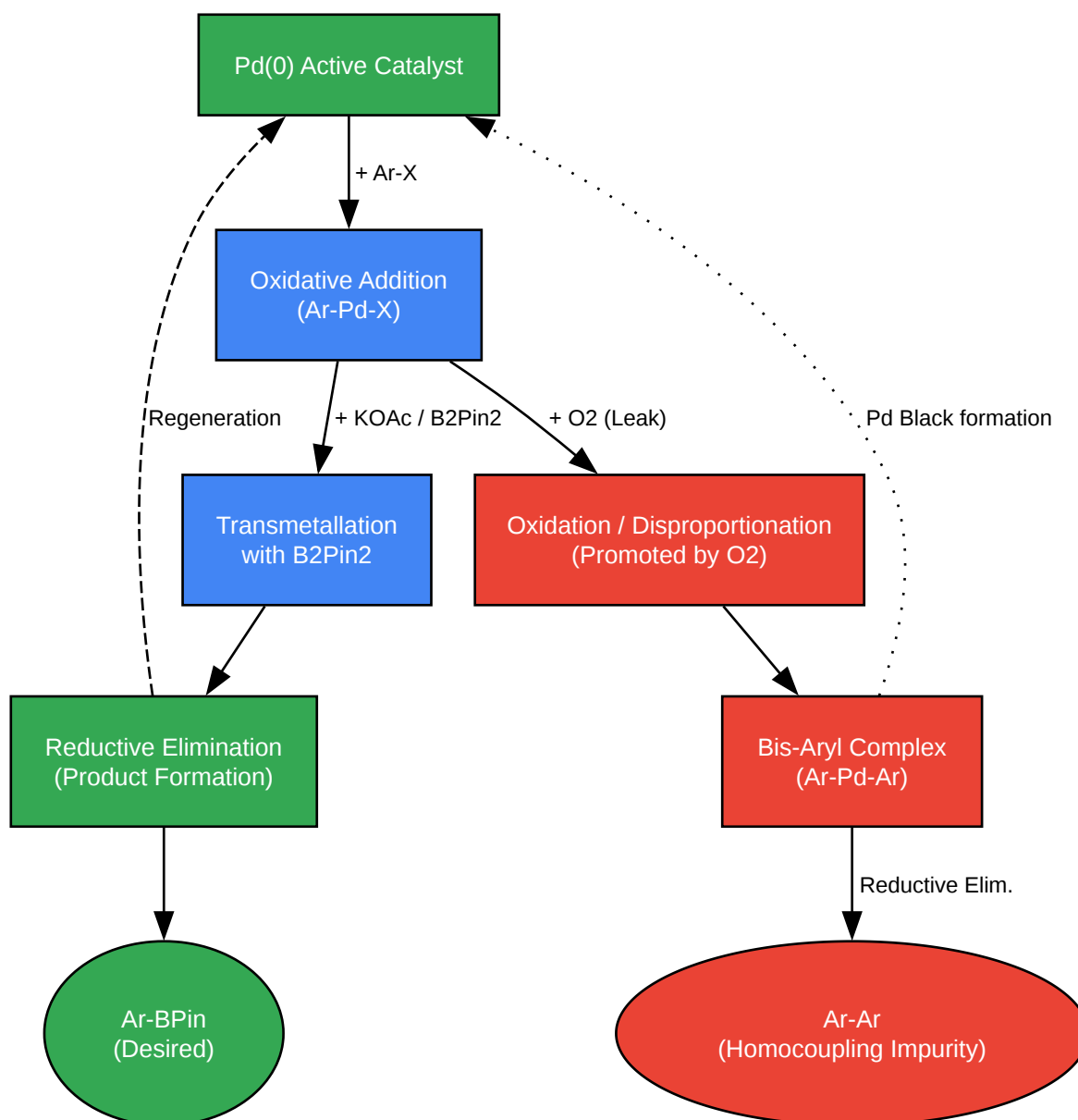

[Click to download full resolution via product page](#)

Figure 1: The divergence of the Palladium catalytic cycle. Oxygen intrusion diverts the oxidative addition complex toward the bis-aryl species, resulting in homocoupling.

Module 2: Lithium-Halogen Exchange (Cryogenic)

The Core Issue: Wurtz-type coupling.^{[1][2]} During the exchange (

), the newly formed highly reactive aryl lithium (

) can react with the remaining unreacted aryl bromide (

) if the temperature is too high or mixing is slower than the reaction rate.

Troubleshooting Guide: Lithiation Protocols

Symptom	Probable Cause	Corrective Action
Significant Ar-Ar impurity	Localized Heating (Hot Spots)	Adding too fast creates local exotherms where , triggering Wurtz coupling. Action: Use a syringe pump for addition. Ensure internal temperature probe (not just bath temp) stays below -70°C.
High Alkyl-Aryl coupling (Ar-Bu)	Slow Exchange Kinetics	The is reacting with the generated butyl bromide (). Action: Use t-BuLi (2 equiv) instead of n-BuLi. The byproduct is isobutylene (gas) and LiBr, which are inert to Wurtz coupling.
Inconsistent Yields / Dimer	Precipitation	species can aggregate or precipitate in pure hexanes/THF, leading to heterogeneity and side reactions. Action: Ensure solvent ratio (THF/Hexane) keeps intermediates soluble.
"Runaway" Coupling	Inverse Addition Required	For extremely sensitive substrates, standard addition fails. Action: Pre-mix the borate () with the aryl halide and add to the mixture (In-Situ Quench). The

is trapped by boron faster than
it can find an

.

Protocol: The "In-Situ Quench" (Barbieri Conditions)

Use this when standard sequential addition yields >10% dimer.

- Dissolve Aryl Halide (1.0 equiv) and Triisopropyl borate (, 1.2 equiv) in anhydrous THF/Toluene (4:1).
- Cool to -78°C.
- Add n-BuLi (1.1 equiv) dropwise down the side of the flask (pre-cooled).
- Mechanism: As

forms, it is immediately intercepted by the proximal borate ester, preventing it from encountering an unreacted

molecule.

Module 3: Purification & Recovery

If homocoupling occurs, the product is not lost. Boronic acids possess a unique "solubility switch" that biaryl impurities lack.

The "pH Swing" Extraction Protocol

Standard chromatography often fails to separate Ar-B(OH)₂ from Ar-Ar due to streaking. Use this chemical separation instead.

- Dissolution: Dissolve the crude mixture (containing Boronic Acid + Dimer) in an organic solvent (DCM or Ethyl Acetate).
- Base Extraction (The Switch):

- Add 2M NaOH (aq).
- Chemistry:
.
- Result: The Boronate salt moves to the Aqueous Layer. The Non-polar Dimer stays in the Organic Layer.
- Separation: Discard the organic layer (contains the homocoupling impurity).
- Acidification:
 - Wash the aqueous layer once with fresh DCM (to remove trace organics).
 - Acidify the aqueous layer carefully with 2M HCl to pH ~5-6.
 - Result:
.
- Isolation: Filter the solid boronic acid or extract with fresh organic solvent.

Visualizing the Workup

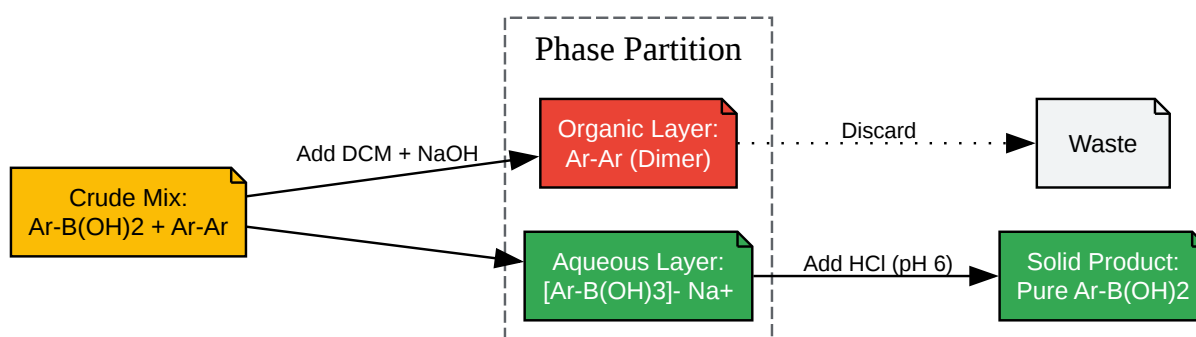

[Click to download full resolution via product page](#)

Figure 2: The "pH Swing" purification logic. Utilizing the amphoteric nature of boron to isolate it from non-polar biaryl impurities.

Frequently Asked Questions (FAQ)

Q: I am using Pd(dppf)Cl₂ and getting 15% homocoupling. Why? A: dppf is a ferrocene-based ligand. While robust, it can sometimes suffer from slow reductive elimination, increasing the lifetime of the active species and allowing oxidation.

- Fix: Switch to Pd(dppf)Cl₂·DCM complex (often higher purity) or, better yet, switch to Pd-XPhos-G2. The bulky XPhos ligand creates a "protective shell" around the Pd center, mechanically blocking the approach of a second aryl group required for homocoupling.

Q: Can I use water to suppress homocoupling in Miyaura borylation? A: Counter-intuitively, yes. Trace water can help.^[3]

- Mechanism: Anhydrous conditions are required for the formation of the active catalyst, but trace water helps dissolve the inorganic base (KOAc), ensuring a steady supply of acetate ions for the transmetallation step. If transmetallation is fast, the catalyst spends less time in the vulnerable state where homocoupling occurs. However, too much water hydrolyzes the BPin ester.
- Recommendation: Do not add water intentionally unless optimizing a specific difficult substrate, but do not obsess over "glovebox dry" solvents; standard anhydrous grades are sufficient.

Q: My Li-halogen exchange works on small scale (100mg) but fails on gram scale (high dimer). A: This is a classic Heat Transfer failure. On small scales, the heat of the reaction dissipates instantly. On gram scale, the addition of nBuLi creates a localized "hot zone" at the tip of the needle/cannula where the temp exceeds -70°C, triggering Wurtz coupling.

- Fix: Slow down the addition rate significantly. Cool the nBuLi solution before addition (using a jacketed addition funnel if possible). Increase stirring speed to maximum to dissipate heat.

References

- Ishiyama, T., Murata, M., & Miyaura, N. (1995).^{[4][5]} Palladium(0)-Catalyzed Cross-Coupling Reaction of Alkoxydiboron with Haloarenes: A Direct Procedure for Arylboronic Esters.^{[4][6]} The Journal of Organic Chemistry. [Link](#)

- Chow, W. K., et al. (2010). Mechanistic Studies on the Palladium-Catalyzed Miyaura Borylation Reaction. *Chemistry – A European Journal*. [Link](#)
- Colacot, T. J. (2015). *New Trends in Cross-Coupling: Theory and Applications*. Royal Society of Chemistry.[6] (Chapter on Side Reactions). [Link](#)
- Lennox, A. J. J., & Lloyd-Jones, G. C. (2014). Selection of Boron Reagents for Suzuki–Miyaura Coupling. *Chemical Society Reviews*. [Link](#)
- Dunetz, J. R., Magano, J., & Weisenburger, G. A. (2016). Large-Scale Applications of Transition Metal-Catalyzed Couplings for the Synthesis of Pharmaceuticals.[6] *Chemical Reviews*. [Link](#)

Need Custom Synthesis?

BenchChem offers custom synthesis for rare earth carbides and specific isotopic labeling.

Email: info@benchchem.com or [Request Quote Online](#).

Sources

- 1. [Wurtz Reaction \[organic-chemistry.org\]](https://www.organic-chemistry.org)
- 2. [chemistry.stackexchange.com \[chemistry.stackexchange.com\]](https://chemistry.stackexchange.com)
- 3. [BJOC - Palladium-catalyzed solid-state borylation of aryl halides using mechanochemistry \[beilstein-journals.org\]](https://beilstein-journals.org)
- 4. [Miyaura borylation - Wikipedia \[en.wikipedia.org\]](https://en.wikipedia.org)
- 5. [Miyaura Borylation Reaction \[organic-chemistry.org\]](https://www.organic-chemistry.org)
- 6. [pure.manchester.ac.uk \[pure.manchester.ac.uk\]](https://pure.manchester.ac.uk)
- To cite this document: BenchChem. [Technical Support Center: Minimizing Homocoupling in Boronic Acid Synthesis]. BenchChem, [2026]. [Online PDF]. Available at: [\[https://www.benchchem.com/product/b14853101/docs#technical-support-center-minimizing-homocoupling-in-boronic-acid-synthesis\]](https://www.benchchem.com/product/b14853101/docs#technical-support-center-minimizing-homocoupling-in-boronic-acid-synthesis)

Disclaimer & Data Validity:

The information provided in this document is for Research Use Only (RUO) and is strictly not intended for diagnostic or therapeutic procedures. While BenchChem strives to provide accurate protocols, we make no warranties, express or implied, regarding the fitness of this product for every specific experimental setup.

Technical Support: The protocols provided are for reference purposes. Unsure if this reagent suits your experiment?

Need Industrial/Bulk Grade? [Request Custom Synthesis Quote](#)

BenchChem

Our mission is to be the trusted global source of essential and advanced chemicals, empowering scientists and researchers to drive progress in science and industry.

Contact

Address: 3281 E Guasti Rd
Ontario, CA 91761, United States
Phone: (601) 213-4426
Email: info@benchchem.com

[Contact our Ph.D. Support Team for a compatibility check](#)