

Gnetin D and its Derivatives in Traditional Medicine: A Technical Guide

Author: BenchChem Technical Support Team. **Date:** December 2025

Compound of Interest

Compound Name: *Gnetin D*

Cat. No.: *B14853135*

[Get Quote](#)

For Researchers, Scientists, and Drug Development Professionals

Introduction

Plants from the Gnetaceae family, particularly *Gnetum gnemon* (commonly known as melinjo), have a history of use in traditional medicine for treating a variety of ailments, including bronchitis, arthritis, and inflammatory conditions.[1][2] Modern phytochemical research has identified a rich source of stilbenoids within these plants, which are believed to be responsible for their therapeutic effects. Among these compounds are **Gnetin D** and its more extensively studied derivative, Gnetin C. These resveratrol oligomers have demonstrated a spectrum of biological activities, including anticancer, anti-inflammatory, antioxidant, and antiviral properties.[1][3][4] This technical guide provides a comprehensive overview of the current scientific understanding of **Gnetin D** and its derivatives, with a focus on their mechanisms of action, quantitative biological data, and the experimental protocols used to elucidate their effects. Due to the larger body of available research, Gnetin C is often used as a reference to illustrate the potential therapeutic pathways of related stilbenoids.

Traditional Uses

Plants of the *Gnetum* genus have been traditionally used in folk medicine across Southeast Asia and other tropical regions. They are often employed to manage conditions with an inflammatory basis, such as arthritis and bronchitis.[2] The seeds and leaves are also consumed as food, suggesting a favorable safety profile.[2] The anticancer and anti-inflammatory properties suggested by traditional use have prompted scientific investigation into

the specific bioactive constituents of these plants, leading to the isolation of numerous stilbenoids, including **Gnetin D**.^{[3][4]}

Quantitative Biological Data

The biological activities of **Gnetin D** and its derivatives have been quantified in various in vitro and in vivo studies. The following tables summarize the key quantitative data, providing a basis for comparison of their potency.

Table 1: In Vitro Anticancer and Antiviral Activity of **Gnetin D** and Derivatives

Compound	Cell Line/Virus	Assay Type	IC50 Value	Reference(s)
Gnetin D	Influenza A/Guangdong/24 3/72 (H3N2)	CPE Reduction	0.67 µg/mL	[3]
Gnetin D	Influenza A/PR/8/34 (H1N1) NA	Neuraminidase Inhibition	10.3 µg/mL	[3]
Gnetin D	Influenza A/Guangdong/24 3/72 (H3N2) NA	Neuraminidase Inhibition	15.7 µg/mL	[3]
Gnetin D	Influenza B/Jiangsu/10/200 3 NA	Neuraminidase Inhibition	26.3 µg/mL	[3]
Gnetin C	Human Leukemia HL60	Growth Inhibition	13 µM	[4]
Gnetin C	Prostate Cancer DU145	Cell Viability	6.6 µM	[5]
Gnetin C	Prostate Cancer PC3M	Cell Viability	8.7 µM	[5]
Prenylated Gnetin D derivative	Murine P-388 Leukemia	Cytotoxicity	25.5 µg/mL	[6]

Table 2: In Vivo Activity of Gnetin C

Compound	Animal Model	Dosage	Effect	Reference(s)
Gnetin C	PC3M-Luc Prostate Cancer Xenograft	25 mg/kg & 50 mg/kg (i.p.)	Inhibition of tumor progression	[5]
Gnetin C	Advanced Prostate Cancer Model	7 mg/kg (i.p.)	Blocked tumor progression via MTA1/Akt/mTOR signaling	[4]
Gnetin C	NAFLD Mouse Model	150 mg/kg/day (dietary)	Ameliorated hepatic steatosis and improved insulin sensitivity	[7]

Signaling Pathways and Mechanisms of Action

Gnetin C, a well-studied resveratrol dimer, has been shown to modulate several key signaling pathways involved in cancer and inflammation. These mechanisms provide a likely framework for the action of structurally similar derivatives like **Gnetin D**.

Anti-inflammatory Signaling

Gnetin C has been shown to exert anti-inflammatory effects by inhibiting the Toll-like receptor 3 (TLR3) signaling pathway. This inhibition leads to a reduction in the production of pro-inflammatory chemokines such as CCL2 and CCL5. A key mechanism in inflammation is the activation of the NF- κ B pathway, which leads to the translocation of the p65 subunit into the nucleus. Gnetin C is proposed to inhibit this translocation, thereby downregulating the expression of inflammatory genes.

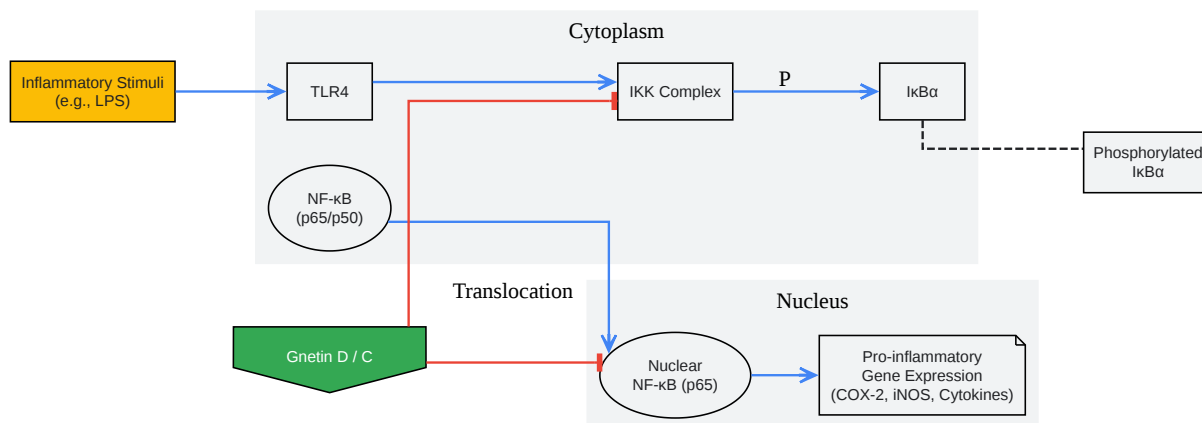

[Click to download full resolution via product page](#)

Caption: Proposed anti-inflammatory mechanism of **Gnetin** derivatives via inhibition of the NF-κB pathway.

Anticancer Signaling Pathways

Gnetin C has demonstrated potent anticancer activity by targeting multiple signaling cascades crucial for cancer cell proliferation, survival, and metastasis.

- **AKT/mTOR Pathway:** This pathway is a central regulator of cell growth and survival and is often hyperactivated in cancer. Gnetin C has been shown to inhibit the phosphorylation of both AKT and mTOR, leading to decreased cell proliferation and induction of apoptosis.[8][9]
- **ERK1/2 Pathway:** The ERK1/2 (also known as MAPK) pathway is another critical regulator of cell proliferation. Inhibition of this pathway by Gnetin C contributes to its antiproliferative effects, particularly in leukemia.[4]
- **MTA1-Mediated Pathway:** Metastasis-associated protein 1 (MTA1) is involved in cancer progression and metastasis. Gnetin C downregulates MTA1, which in turn affects

downstream targets like ETS2, leading to reduced cell viability and metastatic potential in prostate cancer.[4][5]

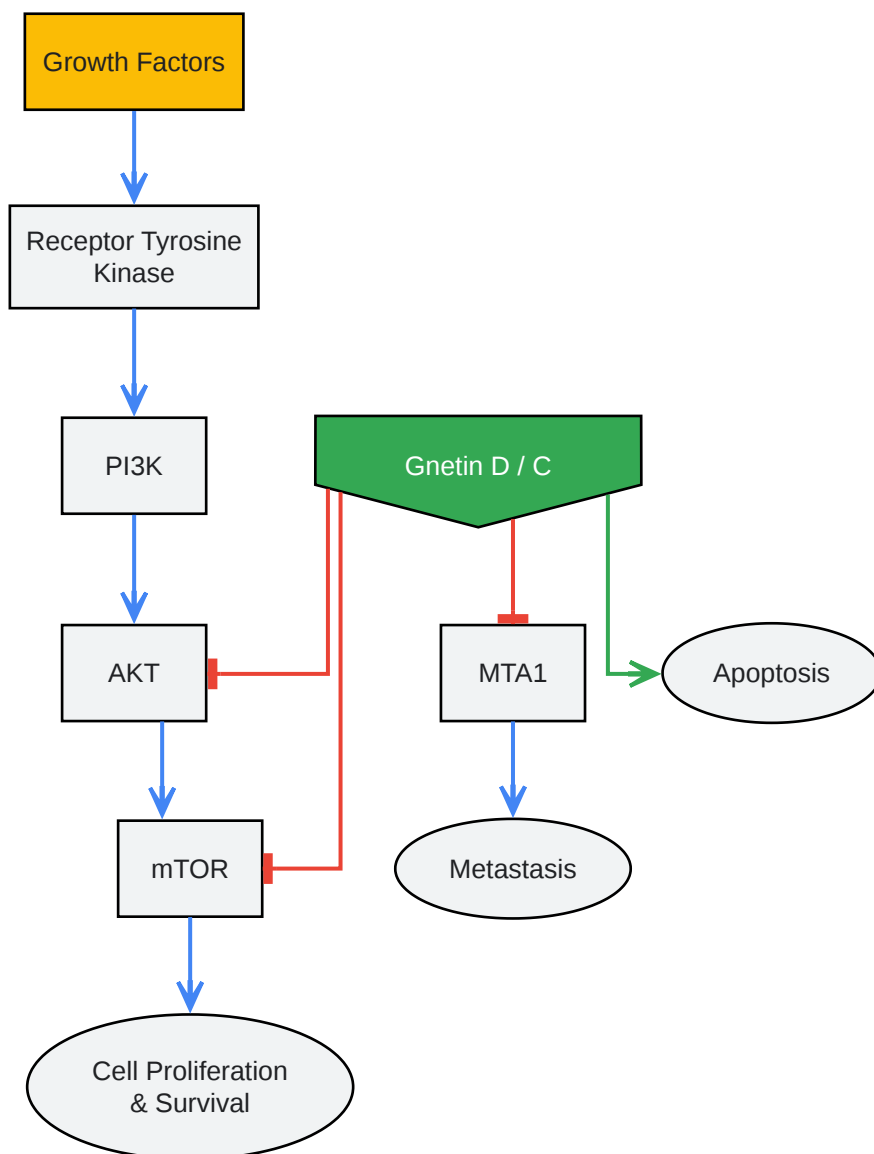

[Click to download full resolution via product page](#)

Caption: Key anticancer signaling pathways inhibited by **Gnetin** derivatives.

Experimental Protocols

To facilitate further research and validation of the reported findings, this section provides detailed methodologies for key experiments.

Protocol 1: Extraction and Isolation of Stilbenoids from Gnetum species

This protocol is adapted from methods described for the isolation of stilbenoids from Gnetum seeds and stems.^{[2][10][11]}

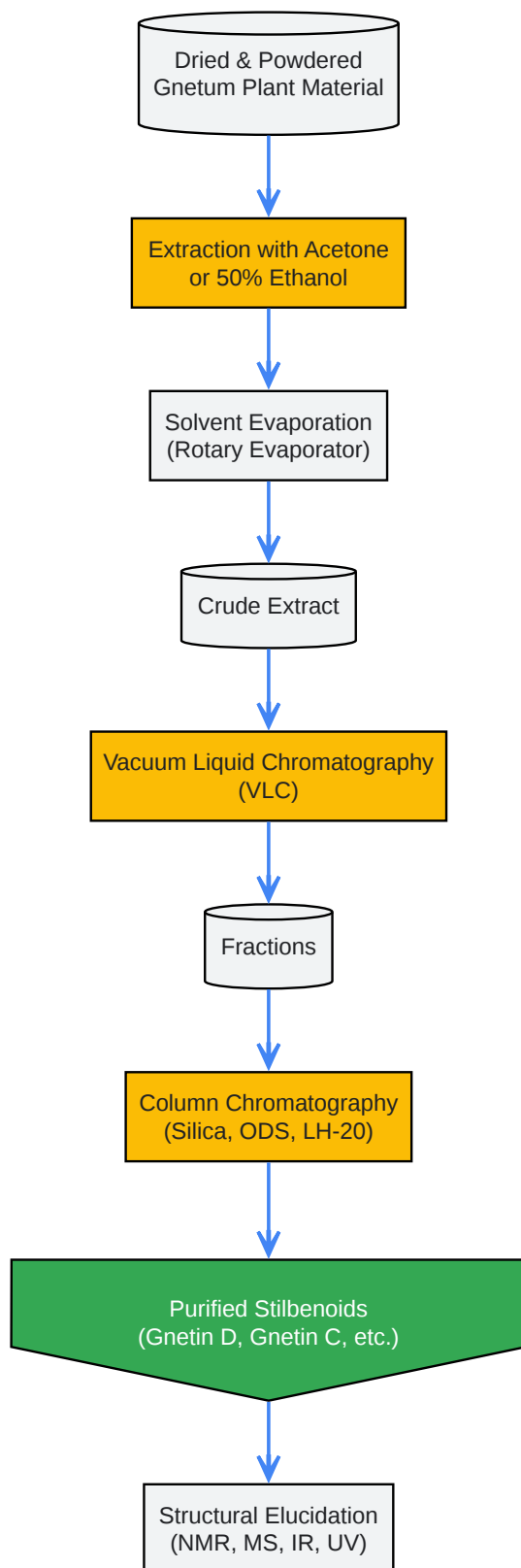

[Click to download full resolution via product page](#)

Caption: General workflow for the extraction and isolation of **Gnetin D** and its derivatives.

- Preparation of Plant Material: Air-dry the seeds or stems of the Gnetum plant, then grind into a fine powder.
- Extraction: Macerate the powdered plant material with a suitable solvent (e.g., acetone or 50% ethanol) at room temperature for 24-48 hours. Repeat the extraction process three times to ensure maximum yield.
- Concentration: Combine the filtrates and concentrate under reduced pressure using a rotary evaporator to obtain the crude extract.
- Fractionation: Subject the crude extract to Vacuum Liquid Chromatography (VLC) on a silica gel column, eluting with a gradient of solvents (e.g., hexane, ethyl acetate, methanol) to separate the extract into several fractions.
- Purification: Further purify the fractions containing stilbenoids using repeated column chromatography on different stationary phases, such as octadecylated silica (ODS) and Sephadex LH-20, until pure compounds are isolated.
- Structural Elucidation: Determine the structures of the isolated compounds using spectroscopic methods, including 1D and 2D Nuclear Magnetic Resonance (NMR), Mass Spectrometry (MS), Infrared (IR), and Ultraviolet (UV) spectroscopy.

Protocol 2: Cell Viability (MTS) Assay

This protocol is a standard method for assessing the effect of compounds on cell proliferation and cytotoxicity.^{[12][13][14]}

- Cell Seeding: Seed cells in a 96-well plate at a density of 5,000-10,000 cells per well in 100 μ L of complete culture medium. Incubate for 24 hours at 37°C in a humidified 5% CO₂ atmosphere.
- Compound Treatment: Prepare serial dilutions of **Gnetin D** or its derivatives in culture medium. Replace the medium in the wells with 100 μ L of the compound-containing medium. Include vehicle-only (e.g., 0.1% DMSO) and medium-only controls.
- Incubation: Incubate the plate for the desired exposure time (e.g., 24, 48, or 72 hours).

- MTS Reagent Addition: Add 20 μ L of MTS reagent solution to each well.
- Incubation with Reagent: Incubate the plate for 1-4 hours at 37°C, protected from light.
- Absorbance Measurement: Measure the absorbance at 490 nm using a microplate reader.
- Data Analysis: Calculate the percentage of cell viability relative to the vehicle control and determine the IC50 value using non-linear regression analysis.

Protocol 3: Western Blot Analysis for AKT/mTOR Pathway

This protocol details the detection of key proteins in the AKT/mTOR signaling pathway.^{[1][15]}
^[16]

- Cell Lysis: After treatment with the compounds, wash the cells with ice-cold PBS and lyse them in RIPA buffer containing protease and phosphatase inhibitors.
- Protein Quantification: Determine the protein concentration of each lysate using a BCA protein assay.
- Sample Preparation: Mix equal amounts of protein (20-40 μ g) with Laemmli sample buffer and heat at 95°C for 5 minutes.
- SDS-PAGE: Separate the protein samples on a 10% SDS-polyacrylamide gel.
- Protein Transfer: Transfer the separated proteins to a PVDF membrane.
- Blocking: Block the membrane with 5% non-fat dry milk or BSA in TBST for 1 hour at room temperature.
- Primary Antibody Incubation: Incubate the membrane with primary antibodies against p-AKT, total AKT, p-mTOR, total mTOR, and a loading control (e.g., β -actin) overnight at 4°C with gentle agitation.
- Secondary Antibody Incubation: Wash the membrane with TBST and incubate with an appropriate HRP-conjugated secondary antibody for 1 hour at room temperature.

- Detection: Wash the membrane again and detect the protein bands using an enhanced chemiluminescence (ECL) substrate and an imaging system.
- Densitometry: Quantify the band intensities using image analysis software and normalize to the loading control.

Protocol 4: Immunofluorescence for NF- κ B p65 Translocation

This protocol allows for the visualization of NF- κ B activation by observing the nuclear translocation of the p65 subunit.[\[17\]](#)[\[18\]](#)

- Cell Culture: Grow cells on glass coverslips in a 24-well plate.
- Treatment: Pre-treat the cells with **Gnetin D** or its derivatives for 1-2 hours, followed by stimulation with an inflammatory agent like LPS (1 μ g/mL) for 30-60 minutes.
- Fixation and Permeabilization: Fix the cells with 4% paraformaldehyde for 15 minutes, then permeabilize with 0.1% Triton X-100 in PBS for 20 minutes.
- Blocking: Block with 3% BSA in PBS for 30 minutes.
- Primary Antibody Incubation: Incubate with a primary antibody against NF- κ B p65 (diluted in 3% BSA/PBS) overnight at 4°C.
- Secondary Antibody Incubation: Wash with PBS and incubate with a fluorescently-labeled secondary antibody (e.g., Alexa Fluor 488) for 1 hour at room temperature in the dark.
- Nuclear Staining and Mounting: Counterstain the nuclei with DAPI and mount the coverslips onto microscope slides.
- Imaging: Visualize the cells using a fluorescence or confocal microscope. Inactivated cells will show p65 staining primarily in the cytoplasm, while activated cells will show a shift of p65 staining to the nucleus.

Conclusion

Gnetin D and its derivatives, isolated from plants used in traditional medicine, represent a promising class of bioactive stilbenoids. The available data, particularly for the well-researched analogue Gnetin C, demonstrate significant anticancer and anti-inflammatory potential through the modulation of key cellular signaling pathways such as NF- κ B, AKT/mTOR, and MTA1. While more research is needed to fully characterize the specific activities and mechanisms of **Gnetin D**, the existing evidence provides a strong rationale for its continued investigation as a potential therapeutic agent. The detailed protocols provided in this guide are intended to support these research efforts and facilitate the development of novel drugs from these natural products.

Need Custom Synthesis?

BenchChem offers custom synthesis for rare earth carbides and specific isotopic labeling.

Email: info@benchchem.com or [Request Quote Online](#).

References

- 1. pubcompare.ai [pubcompare.ai]
- 2. benthamopen.com [benthamopen.com]
- 3. Natural and nature-inspired stilbenoids as antiviral agents - PMC [pmc.ncbi.nlm.nih.gov]
- 4. Gnetin C in Cancer and Other Diseases: What Do We Know So Far? [mdpi.com]
- 5. Therapeutic Potential of Gnetin C in Prostate Cancer: A Pre-Clinical Study - PMC [pmc.ncbi.nlm.nih.gov]
- 6. pubs.aip.org [pubs.aip.org]
- 7. Protective Effects of Gnetin C from Melinjo Seed Extract against High-Fat Diet-Induced Hepatic Steatosis and Liver Fibrosis in NAFLD Mice Model - PMC [pmc.ncbi.nlm.nih.gov]
- 8. The Therapeutic Efficacy and Mechanism of Action of Gnetin C, a Natural Compound from the Melinjo Plant, in a Preclinical Mouse Model of Advanced Prostate Cancer - PMC [pmc.ncbi.nlm.nih.gov]
- 9. Investigation of Antioxidant and Anticancer Activity against MCF-7 and HeLa Cancer Cells of Melinjo (*Gnetum gnemon* L.) – Biomedical and Pharmacology Journal [biomedpharmajournal.org]
- 10. researchgate.net [researchgate.net]

- 11. pubs.acs.org [pubs.acs.org]
- 12. Cell Viability Assays - Assay Guidance Manual - NCBI Bookshelf [ncbi.nlm.nih.gov]
- 13. MTS Tetrazolium Assay Protocol - Creative Bioarray | Creative Bioarray [creative-bioarray.com]
- 14. broadpharm.com [broadpharm.com]
- 15. 1.2 Western Blot and the mTOR Pathway – Selected Topics in Health and Disease (2019 Edition) [ecampusontario.pressbooks.pub]
- 16. Evaluating the mTOR Pathway in Physiological and Pharmacological Settings - PMC [pmc.ncbi.nlm.nih.gov]
- 17. Immunostaining of NF-κB p65 Nuclear Translocation [bio-protocol.org]
- 18. pubcompare.ai [pubcompare.ai]
- To cite this document: BenchChem. [Gnetin D and its Derivatives in Traditional Medicine: A Technical Guide]. BenchChem, [2025]. [Online PDF]. Available at: [<https://www.benchchem.com/product/b14853135#gnetin-d-and-its-derivatives-in-traditional-medicine>]

Disclaimer & Data Validity:

The information provided in this document is for Research Use Only (RUO) and is strictly not intended for diagnostic or therapeutic procedures. While BenchChem strives to provide accurate protocols, we make no warranties, express or implied, regarding the fitness of this product for every specific experimental setup.

Technical Support: The protocols provided are for reference purposes. Unsure if this reagent suits your experiment? [[Contact our Ph.D. Support Team for a compatibility check](#)]

Need Industrial/Bulk Grade? [Request Custom Synthesis Quote](#)

BenchChem

Our mission is to be the trusted global source of essential and advanced chemicals, empowering scientists and researchers to drive progress in science and industry.

Contact

Address: 3281 E Guasti Rd

Ontario, CA 91761, United States

Phone: (601) 213-4426

Email: info@benchchem.com