

Application Note: High-Performance Williamson Ether Synthesis for Sterically Hindered Phenols

Author: BenchChem Technical Support Team. **Date:** April 2026

Compound of Interest

Compound Name: 2-(Tert-butoxy)-3-methoxyphenol

Cat. No.: B14840763

[Get Quote](#)

Abstract & Strategic Overview

The Williamson ether synthesis is a foundational transformation in organic chemistry, yet it frequently fails when applied to sterically hindered phenols (e.g., 2,6-disubstituted scaffolds common in propofol derivatives, tocopherols, and antioxidant stabilizers).[1]

For drug development professionals, the failure mode is typically not a lack of reactivity, but a lack of selectivity. The hindered phenoxide anion is an ambident nucleophile; when the oxygen center is sterically shielded, reaction rates drop, and competing pathways—specifically C-alkylation and E2 elimination of the alkyl halide—dominate.

This guide details two optimized protocols designed to overcome the "ortho-effect" through precise manipulation of cation solvation, lattice energy, and solvent polarity.

Mechanistic Insight: The Steric-Electronic Conflict

To optimize yields, one must understand the competition at the molecular level. In hindered phenols, the bulky ortho-groups prevent the electrophile (alkyl halide) from approaching the oxygen atom (SN2 pathway).

The Cesium Effect

Standard bases like

or

often fail because

and

form tight ion pairs with the phenoxide oxygen, further crowding the reactive site.

- Solution: Cesium Carbonate ([K2CO3](#))
).[\[1\]](#)

- Causality: The Cesium ion ([Cs+](#))

) has a large ionic radius (1.67 Å) and low charge density.[\[1\]](#) It forms a "loose" or solvent-separated ion pair with the phenoxide. This exposes the oxygen atom ("naked anion effect"), significantly increasing its nucleophilicity despite steric hindrance [\[1\]](#).

Pathway Competition Visualized

The following diagram illustrates the kinetic competition you must control.

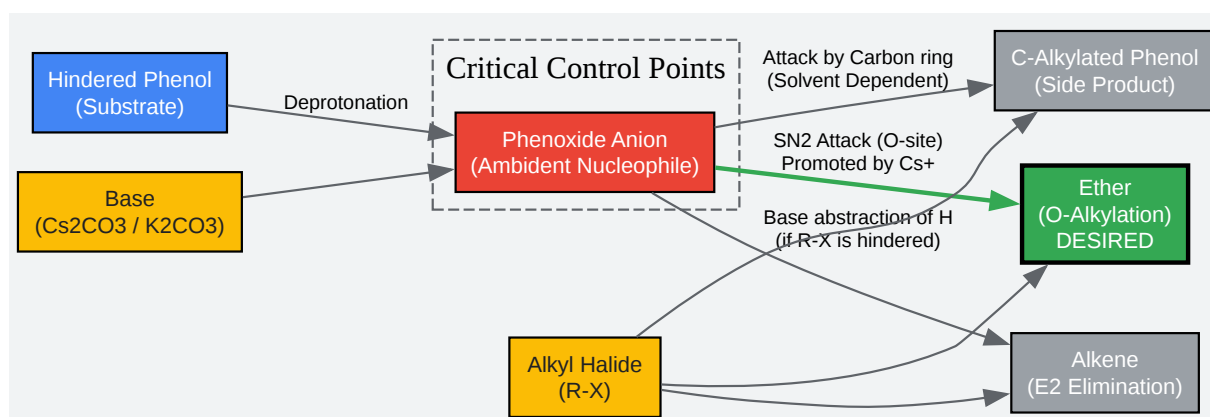

[Click to download full resolution via product page](#)

Figure 1: Mechanistic divergence in hindered phenol alkylation. Success depends on maximizing the SN2 vector (Green).

Critical Parameters & Optimization Matrix

The choice of solvent and leaving group is not arbitrary; it dictates the ratio of O-alkylation vs. C-alkylation.

Solvent Selection Table

Polar aprotic solvents are required to strip the cation. However, Acetonitrile (MeCN) often provides better O/C selectivity than DMF for certain substrates due to specific solvation effects [2].

Parameter	DMF / DMAc	Acetonitrile (MeCN)	Acetone	Toluene (PTC)
Dielectric Constant	High (36-38)	High (37.[1]5)	Medium (21)	Low (2.4)
Cation Solvation	Excellent	Good	Moderate	Poor (Requires Crown Ether)
Reaction Temp	Up to 150°C	Reflux (82°C)	Reflux (56°C)	Variable
Primary Use	Severe Hindrance	Moderate Hindrance	Easy Substrates	Scale-up / Green Chem
Risk	Thermal decomp at >140°C	Slow kinetics for bulky R-X	Too slow for hindered phenols	Requires Catalyst

Leaving Group Hierarchy

For hindered phenols, the transition state is late.[1] You need a hyper-active electrophile.

- Iodide (I): Best.[1] If R-I is unstable, generate it in situ using Finkelstein conditions (add 10 mol% KI or NaI to R-Br) [3].
- Bromide (Br): Standard.

- Tosylate/Mesylate: Good, but often bulkier than halides, which adds to the steric problem.[1]
- Chloride (Cl): Generally too unreactive for hindered SN2 without high heat (which promotes elimination).[1]

Experimental Protocols

Protocol A: The "Cesium Effect" Method (High Difficulty Substrates)

Best for: 2,6-diisopropylphenol, 2,6-dichlorophenol, and lab-scale discovery chemistry.[1]

Reagents:

- Substrate: Hindered Phenol (1.0 equiv)[1]
- Base: Cesium Carbonate (), 1.5 – 2.0 equiv.
- Electrophile: Alkyl Iodide (1.2 – 1.5 equiv) or Alkyl Bromide + NaI (0.1 equiv).[1]
- Solvent: Anhydrous DMF (0.2 M concentration).

Step-by-Step:

- Drying: Flame-dry a round-bottom flask under Argon/Nitrogen flow. Note: Phenoxides are oxidation-sensitive; inert atmosphere is mandatory.
- Deprotonation: Add Phenol and to the flask. Add anhydrous DMF. Stir at Room Temperature (RT) for 30 minutes.
 - Observation: The mixture may turn yellow/orange, indicating phenoxide formation.
- Addition: Add the Alkyl Halide dropwise via syringe.
- Reaction: Heat to 60–80°C. Monitor via TLC/LC-MS.

- Checkpoint: If reaction stalls after 4 hours, add another 0.5 equiv of alkyl halide.
- Workup: Cool to RT. Dilute with Ethyl Acetate.[2] Wash 3x with water (critical to remove DMF) and 1x with brine. Dry over

[2]

Protocol B: Solid-Liquid Phase Transfer Catalysis (PTC)

Best for: Scale-up, moisture-sensitive electrophiles, or when DMF workup is undesirable.[1]

Reagents:

- Base: Potassium Hydroxide (KOH), pulverized pellets (3.0 equiv).
- Catalyst: 18-Crown-6 (5-10 mol%) or TBAB (Tetrabutylammonium bromide).[1]
- Solvent: Toluene or DCM.

Step-by-Step:

- Setup: Charge flask with pulverized KOH and solvent.
- Catalyst: Add 18-Crown-6. Stir for 10 mins to establish the phase-transfer complex.
- Reactants: Add Hindered Phenol (1.0 equiv) and Alkyl Halide (1.5 equiv) simultaneously.
- Conditions: Reflux (Toluene) or vigorous stir at 40°C (DCM) for 12-24 hours.

- Mechanism:[1][3][4][5][6][7][8] The Crown ether solubilizes

into the organic phase, dragging the "naked" phenoxide with it to react with the alkyl halide [4].

Troubleshooting & Optimization Workflow

If the standard protocols yield <50%, execute this logic flow.

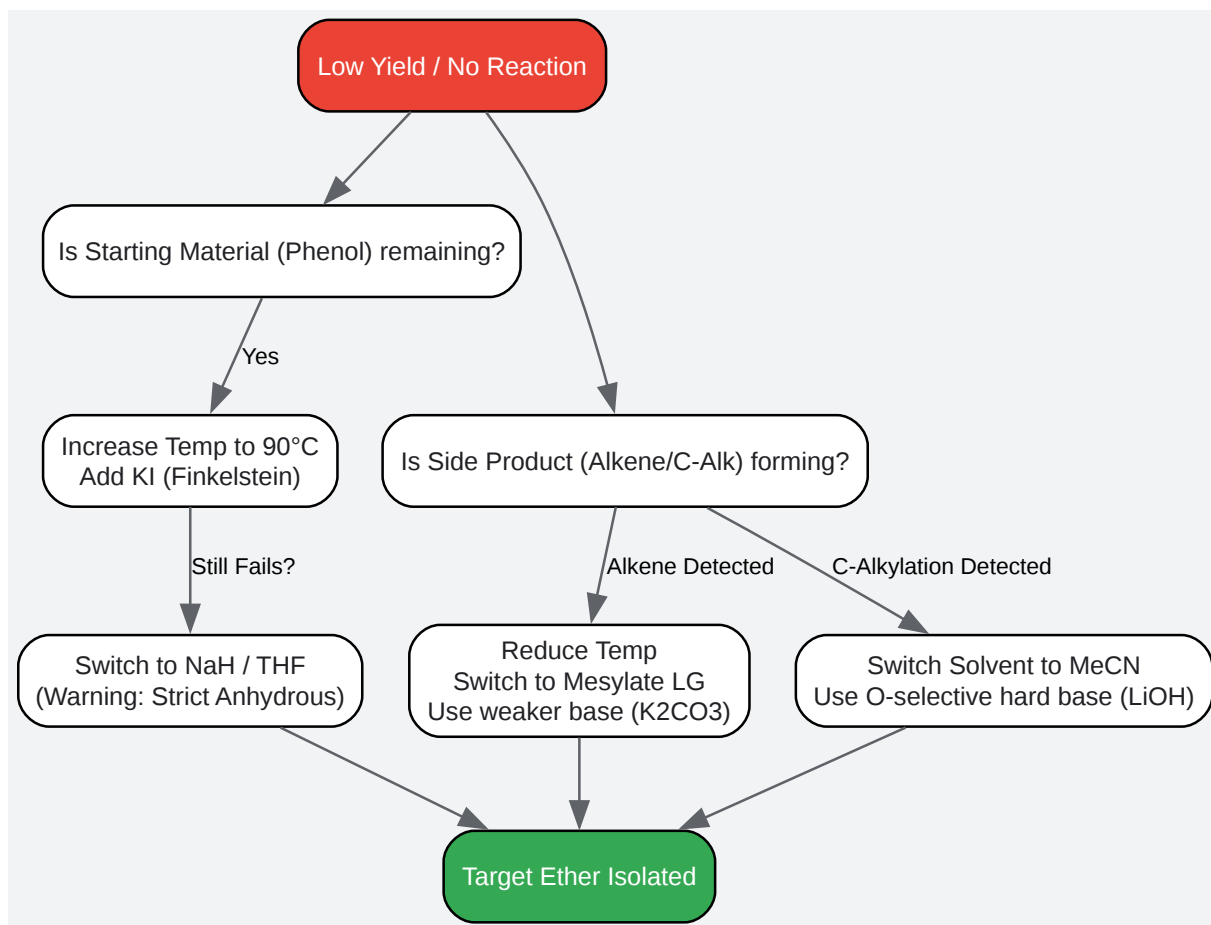

[Click to download full resolution via product page](#)

Figure 2: Decision matrix for troubleshooting hindered ether synthesis.

Common Failure Modes

- The "Inert" Substrate: 2,6-di-tert-butylphenol is effectively inert to SN2 Williamson conditions due to extreme steric blocking.^[1]
 - Corrective Action: Do not use Williamson. Switch to oxidative coupling or use a Mitsunobu reaction (though Mitsunobu also struggles with extreme sterics).
- Black Tar Formation: Phenoxide oxidation.
 - Corrective Action: Degas solvents thoroughly. Ensure strict atmosphere.

References

- Finkelstein, H. et al. "The Cesium Effect: Enhanced Reactivity of Carboxylate and Phenoxide Anions." Journal of Organic Chemistry.
- RSC Publishing. "Mechanism, kinetics and selectivity of a Williamson ether synthesis: elucidation under different reaction conditions." [1] Reaction Chemistry & Engineering. Available at: [\[Link\]](#)
- Master Organic Chemistry. "The Williamson Ether Synthesis." Master Organic Chemistry. Available at: [\[Link\]](#)
- ChemTalk. "Williamson Ether Synthesis: Mechanisms and Conditions." ChemTalk. Available at: [\[Link\]](#)

Need Custom Synthesis?

BenchChem offers custom synthesis for rare earth carbides and specific isotopic labeling.

Email: info@benchchem.com or [Request Quote Online](#).

Sources

- [1. mdpi.com \[mdpi.com\]](#)
- [2. pdf.benchchem.com \[pdf.benchchem.com\]](#)
- [3. byjus.com \[byjus.com\]](#)
- [4. Williamson ether synthesis - Wikipedia \[en.wikipedia.org\]](#)
- [5. masterorganicchemistry.com \[masterorganicchemistry.com\]](#)
- [6. Mechanism, kinetics and selectivity of a Williamson ether synthesis: elucidation under different reaction conditions - Reaction Chemistry & Engineering \(RSC Publishing\) \[pubs.rsc.org\]](#)
- [7. Williamson Ether Synthesis | ChemTalk \[chemistrytalk.org\]](#)
- [8. Williamson Synthesis \[organic-chemistry.org\]](#)
- To cite this document: BenchChem. [Application Note: High-Performance Williamson Ether Synthesis for Sterically Hindered Phenols]. BenchChem, [2026]. [Online PDF]. Available at:

[\[https://www.benchchem.com/product/b14840763/docs#application-note-high-performance-williamson-ether-synthesis-for-sterically-hindered-phenols\]](https://www.benchchem.com/product/b14840763/docs#application-note-high-performance-williamson-ether-synthesis-for-sterically-hindered-phenols)

Disclaimer & Data Validity:

The information provided in this document is for Research Use Only (RUO) and is strictly not intended for diagnostic or therapeutic procedures. While BenchChem strives to provide accurate protocols, we make no warranties, express or implied, regarding the fitness of this product for every specific experimental setup.

Technical Support: The protocols provided are for reference purposes. Unsure if this reagent suits your experiment?

Need Industrial/Bulk Grade? [Request Custom Synthesis Quote](#)

BenchChem

Our mission is to be the trusted global source of essential and advanced chemicals, empowering scientists and researchers to drive progress in science and industry.

Contact

Address: 3281 E Guasti Rd
Ontario, CA 91761, United States
Phone: (601) 213-4426
Email: info@benchchem.com

[Contact our Ph.D. Support Team for a compatibility check](#)