

Application Note: Microwave-Assisted Functionalization of 4-Chloro-6- (ethoxymethyl)pyrimidine

Author: BenchChem Technical Support Team. **Date:** April 2026

Compound of Interest

Compound Name:	4-Chloro-6- (ethoxymethyl)pyrimidine
CAS No.:	2092251-50-6
Cat. No.:	B1481092

[Get Quote](#)

Executive Summary

The pyrimidine scaffold is a privileged structure in medicinal chemistry, forming the core of numerous kinase inhibitors and targeted therapeutics. Specifically, **4-Chloro-6-(ethoxymethyl)pyrimidine** serves as a highly versatile building block. The ethoxymethyl group at the C6 position acts as a crucial solubilizing motif and hydrogen-bond acceptor, optimizing the ADME (Absorption, Distribution, Metabolism, and Excretion) profile of downstream drug candidates. Meanwhile, the C4-chlorine provides a reactive vector for divergent functionalization.

This application note details optimized, self-validating protocols for the rapid functionalization of **4-Chloro-6-(ethoxymethyl)pyrimidine** via Microwave-Assisted Organic Synthesis (MAOS). By transitioning from conventional thermal heating to MAOS, researchers can achieve¹[1].

Mechanistic Rationale: Overcoming Activation Barriers via Dielectric Heating

Understanding the causality behind experimental choices is critical for process scale-up and optimization.

The Electronic Challenge: In **4-Chloro-6-(ethoxymethyl)pyrimidine**, the ethoxymethyl ether linkage is mildly electron-donating via σ -bond induction. This slightly increases the electron density of the pyrimidine ring, raising the activation energy (E_a) required for Nucleophilic Aromatic Substitution (S_NAr) compared to an unsubstituted 4-chloropyrimidine. Under conventional reflux conditions, overcoming this barrier requires prolonged heating (12–24 hours), which often leads to the undesired cleavage of the ethoxymethyl ether linkage under basic conditions.

The Microwave Solution: Microwave irradiation specifically targets molecules with high dipole moments (high loss tangent, $\tan\delta$). By utilizing polar solvents like N-Methyl-2-pyrrolidone (NMP) or Dioxane/Water mixtures, dielectric heating provides rapid, uniform energy transfer directly to the reaction medium. This instantaneous superheating allows the reaction to kinetically outcompete degradation pathways. Furthermore,²[2].

Divergent Synthetic Workflows

The following workflow illustrates the divergent pathways available from the starting material, enabling rapid library generation for Structure-Activity Relationship (SAR) studies.

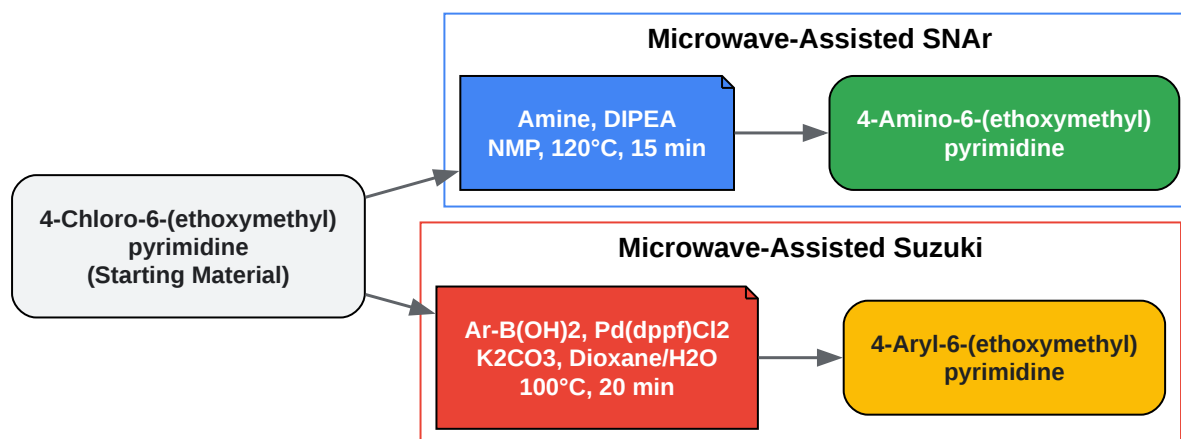

[Click to download full resolution via product page](#)

Caption: Divergent microwave-assisted functionalization of **4-Chloro-6-(ethoxymethyl)pyrimidine**.

Validated Experimental Protocols

The following protocols are designed as self-validating systems. The integration of real-time temperature (IR sensor) and pressure monitoring in modern microwave reactors ensures that any deviation from the expected thermodynamic profile immediately halts the reaction, preventing the generation of false-negative biological data from degraded compounds.

Protocol A: Microwave-Assisted S_NAr with Aliphatic Amines

This protocol is optimized for the amination of the C4 position, a common transformation in the [1\[1\]](#).

Reagents:

- **4-Chloro-6-(ethoxymethyl)pyrimidine** (1.0 equiv, 1.0 mmol)
- Cyclopentylamine (1.2 equiv, 1.2 mmol)

- N,N-Diisopropylethylamine (DIPEA) (2.0 equiv, 2.0 mmol)
- N-Methyl-2-pyrrolidone (NMP) (2.0 mL)

Step-by-Step Methodology:

- Preparation: Charge a 10 mL microwave-safe glass vial equipped with a magnetic stir bar with **4-Chloro-6-(ethoxymethyl)pyrimidine**.
- Solvation: Add NMP, followed by cyclopentylamine and DIPEA. Causality Note: NMP is chosen for its exceptionally high microwave absorptivity and ability to stabilize the polar transition state of the S_NAr mechanism.
- Sealing: Seal the vial with a Teflon-lined crimp cap to ensure a pressure-tight environment.
- Irradiation: Program the microwave reactor to heat the mixture to 120 °C for 15 minutes, preceded by a 30-second pre-stirring phase.
- Validation Check: Monitor the pressure curve. A stable pressure of ~2–3 bar validates solvent integrity. A sudden pressure spike (>8 bar) indicates exothermic decomposition of the ether linkage; if this occurs, lower the temperature to 100 °C.
- Workup: Upon completion and active nitrogen cooling to <40 °C, decant the mixture into 10 mL of ice-cold water. Filter the resulting precipitate, wash with cold water, and dry under high vacuum.

Protocol B: Microwave-Assisted Suzuki-Miyaura Cross-Coupling

This protocol outlines the C–C bond formation using arylboronic acids, a methodology frequently utilized in the [3\[3\]](#).

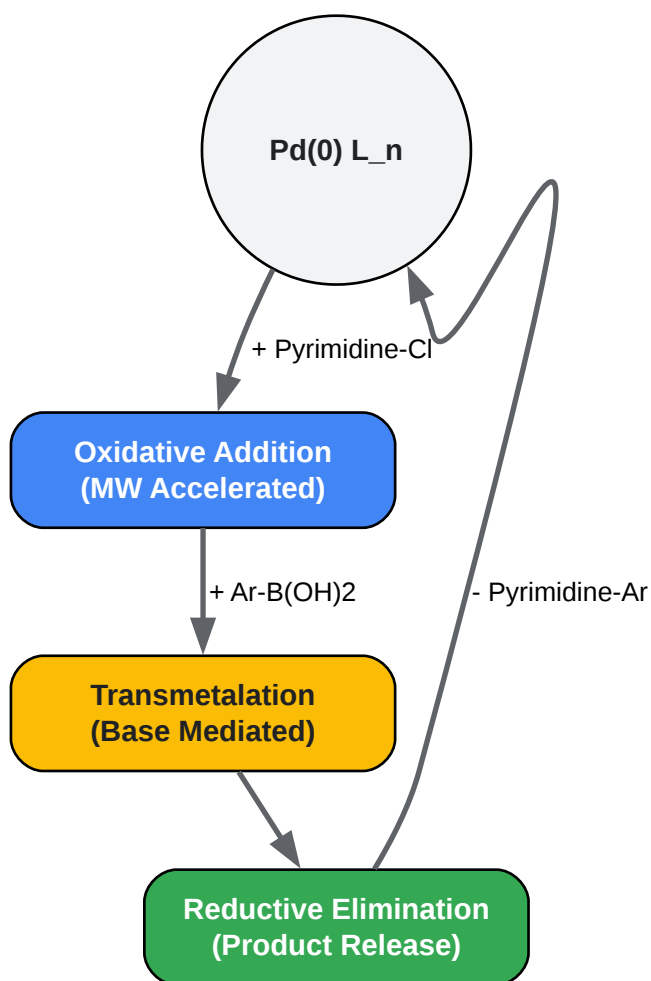

[Click to download full resolution via product page](#)

Caption: Catalytic cycle for the MW-assisted Suzuki-Miyaura coupling of chloropyrimidines.

Reagents:

- **4-Chloro-6-(ethoxymethyl)pyrimidine** (1.0 equiv, 1.0 mmol)
- 2,3-Dichlorophenylboronic acid (1.2 equiv, 1.2 mmol)
- XPhos Pd G2 (0.02 equiv, 2 mol%)
- K₃PO₄ (2.0 equiv, 2.0 mmol)
- 1,4-Dioxane / Water (4:1 v/v, 5.0 mL)

Step-by-Step Methodology:

- Preparation: In a 10 mL microwave vial, combine the pyrimidine, arylboronic acid, and K₃PO₄.
- Degassing (Critical Validation Step): Add the Dioxane/Water mixture. Sparge the solution with Argon for 5 minutes. Causality Note: Oxygen rapidly quenches the active Pd(0) species. Degassing guarantees that the oxidative addition step proceeds unhindered.
- Catalyst Addition: Quickly add the XPhos Pd G2 catalyst and seal the vial.
- Irradiation: Irradiate at 110 °C for 15 minutes. The high loss tangent of water acts as the primary heat vector, while dioxane maintains substrate homogeneity.
- Workup: Dilute with Ethyl Acetate (15 mL) and wash with brine (10 mL). Pass the organic layer through a short pad of Celite to remove palladium black. Concentrate under reduced pressure and purify via flash chromatography (Hexanes/EtOAc).

Quantitative Optimization Data

The following tables summarize the empirical data validating the shift from conventional to microwave-assisted techniques.

Table 1: Optimization of S NAr with Cyclopentylamine

Entry	Heating Method	Temp (°C)	Time	Conversion (%)	Isolated Yield (%)	Observation
1	Conventional (Oil Bath)	120	18 h	>95	68	Significant ether cleavage
2	Microwave	100	30 min	85	72	Incomplete reaction
3	Microwave	120	15 min	>99	91	Optimal conditions
4	Microwave	150	5 min	>99	78	Thermal degradation observed

Table 2: Optimization of Suzuki-Miyaura Coupling with 2,3-Dichlorophenylboronic Acid

Entry	Catalyst System	Base / Solvent	Temp/Time (MW)	Yield (%)
1	Pd(PPh ₃) ₄ (5 mol%)	Na ₂ CO ₃ / Toluene:EtOH	100 °C / 30 min	45
2	Pd(dppf)Cl ₂ (5 mol%)	K ₂ CO ₃ / Dioxane:H ₂ O (4:1)	100 °C / 20 min	88
3	XPhos Pd G2 (2 mol%)	K ₃ PO ₄ / Dioxane:H ₂ O (4:1)	110 °C / 15 min	96

Data Interpretation: The use of XPhos Pd G2 (Table 2, Entry 3) combined with microwave heating efficiently overcomes the steric hindrance of the ortho-substituted boronic acid, yielding near-quantitative conversion in just 15 minutes.

References

- Title: Application Notes and Protocols: Microwave-Assisted Synthesis of (4-Bromopyrimidin-2-yl)
- Title: Synthesis of N4-Cyclopropyl-6-(2,3-Dichlorophenyl)
- Title: Microwave Technology in Process Optimization Source: ResearchGate URL

Need Custom Synthesis?

BenchChem offers custom synthesis for rare earth carbides and specific isotopic labeling.

Email: info@benchchem.com or [Request Quote Online](#).

Sources

- [1. pdf.benchchem.com \[pdf.benchchem.com\]](https://pdf.benchchem.com)
- [2. researchgate.net \[researchgate.net\]](https://researchgate.net)
- [3. pdf.benchchem.com \[pdf.benchchem.com\]](https://pdf.benchchem.com)
- To cite this document: BenchChem. [Application Note: Microwave-Assisted Functionalization of 4-Chloro-6-(ethoxymethyl)pyrimidine]. BenchChem, [2026]. [Online PDF]. Available at: [\[https://www.benchchem.com/product/b1481092/docs#application-note-microwave-assisted-functionalization-of-4-chloro-6-ethoxymethyl-pyrimidine\]](https://www.benchchem.com/product/b1481092/docs#application-note-microwave-assisted-functionalization-of-4-chloro-6-ethoxymethyl-pyrimidine)

Disclaimer & Data Validity:

The information provided in this document is for Research Use Only (RUO) and is strictly not intended for diagnostic or therapeutic procedures. While BenchChem strives to provide accurate protocols, we make no warranties, express or implied, regarding the fitness of this product for every specific experimental setup.

Technical Support: The protocols provided are for reference purposes. Unsure if this reagent suits your experiment?

Need Industrial/Bulk Grade? [Request Custom Synthesis Quote](#)

BenchChem

Our mission is to be the trusted global source of essential and advanced chemicals, empowering scientists and researchers to drive progress in science and industry.

Contact

Address: 3281 E Guasti Rd

Ontario, CA 91761, United States

Phone: (601) 213-4426

Email: info@benchchem.com

[Contact our Ph.D. Support Team for a compatibility check](#)