

Application Notes & Protocols: Picolyl-azide-NH₂ in Advanced Proteomics and Mass Spectrometry

Author: BenchChem Technical Support Team. **Date:** May 2026

Compound of Interest

Compound Name: *picolyl-azide-NH₂*

Cat. No.: *B14802606*

[Get Quote](#)

Abstract: The advent of bioorthogonal chemistry has revolutionized the study of proteins in their native environments. Among the chemical tools developed, picolyl azide reagents have emerged as a superior class of probes for Copper(I)-catalyzed Azide-Alkyne Cycloaddition (CuAAC), or "click chemistry." This guide provides an in-depth exploration of picolyl azide chemistry, its mechanistic advantages, and its applications in proteomics and mass spectrometry. We present detailed protocols for affinity purification, cross-linking mass spectrometry (XL-MS), and photo-affinity labeling (PAL), offering researchers, scientists, and drug development professionals a comprehensive resource for leveraging this powerful technology.

The Picolyl Azide Advantage: A Mechanistic Overview

The azide functional group is a cornerstone of bioorthogonal chemistry, prized for its small size, stability in biological systems, and specific reactivity with alkynes.[1][2] While the standard CuAAC reaction is highly efficient, concerns over the cytotoxicity of the required copper catalyst have persisted, particularly for live-cell imaging and in-vivo applications.[3]

Picolyl azide reagents were engineered to address this fundamental challenge. The key innovation is the incorporation of a picolyl moiety—a pyridine ring with a methylene linker to the azide. This structure acts as an internal copper-chelating ligand.^{[4][5]}

Causality Behind the Enhanced Performance:

- **Increased Effective Copper Concentration:** The picolyl group chelates the Cu(I) catalyst, effectively recruiting it and raising its local concentration at the site of the azide.^{[6][7]} This intramolecular assistance dramatically accelerates the cycloaddition reaction.
- **Reduced Catalyst Requirement:** Due to the enhanced reaction kinetics, the overall concentration of the copper catalyst can be reduced by at least tenfold without sacrificing labeling efficiency.^{[7][8]} This significantly improves the biocompatibility of the labeling protocol, making it more suitable for sensitive biological systems.
- **Superior Signal Intensity:** The faster and more efficient labeling translates directly to a substantial increase in signal intensity, with reports of up to a 40-fold improvement compared to conventional azides.^{[6][7]} This is critical for the detection of low-abundance proteins.

The diagram below illustrates this principle, showing how the picolyl group coordinates with the copper catalyst to facilitate the reaction with an alkyne-modified protein.

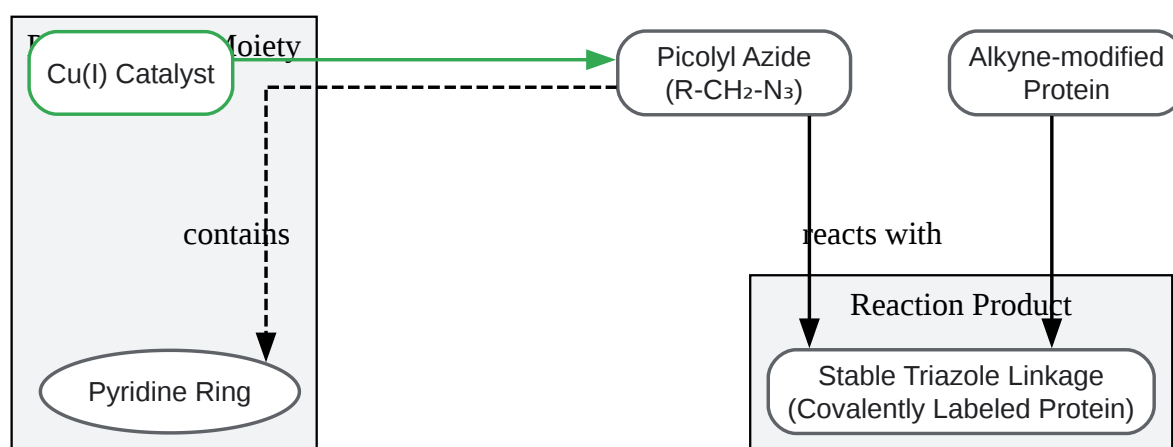

[Click to download full resolution via product page](#)

Caption: Picolyl azide enhances CuAAC by chelating the copper catalyst.

Application: Affinity Purification of Labeled Proteomes

A primary application of picolyl azide is in the enrichment of specific protein populations from complex mixtures. By using a picolyl azide probe functionalized with an affinity handle, such as biotin, researchers can selectively capture alkyne-labeled proteins for subsequent identification and quantification by mass spectrometry.

Principle of the Workflow: This workflow begins with the metabolic incorporation of an alkyne-bearing amino acid analog (e.g., L-homopropargylglycine, HPG) into newly synthesized proteins. Cells are then lysed, and the alkyne-labeled proteins are covalently tagged with a biotin-picolyl azide probe. The enhanced kinetics of the picolyl azide allows this "click" reaction to proceed rapidly and with minimal catalyst. The biotinylated proteins are then captured on streptavidin-coated beads, washed under stringent conditions to remove non-specific binders, and finally digested for mass spectrometry analysis.

The table below summarizes the typical improvements seen when using picolyl azide probes over conventional azide probes in this application.

Parameter	Conventional Azide Probe	Picolyl Azide Probe	Advantage
Required Cu(I) Concentration	100-200 μ M	10-20 μ M	>10x reduction in copper toxicity[5][7]
Typical Reaction Time	1-2 hours	15-30 minutes	Faster workflow, less sample degradation
Relative Signal Output	1x	Up to 40x	Greatly enhanced sensitivity[6][7]

Protocol: Enrichment of Newly Synthesized Proteins using Biotin-Picolyl Azide

This protocol is designed for the enrichment of alkyne-labeled proteins from cultured mammalian cells for subsequent LC-MS/MS analysis.

Self-Validation: The protocol includes an essential negative control (unlabeled cells) to assess non-specific binding to the affinity resin. A successful enrichment will show a dramatic increase in identified proteins in the labeled sample compared to the control.

Materials:

- Cells cultured with an alkyne-amino acid analog (e.g., HPG) and a parallel unlabeled control culture.
- Lysis Buffer: RIPA or similar, supplemented with protease and phosphatase inhibitors.
- Biotin-Picoyl Azide (e.g., from Vector Labs, Biotium).
- Click Reaction Buffer Components: Copper(II) Sulfate (CuSO_4), reducing agent (e.g., THPTA, Sodium Ascorbate).
- Streptavidin-agarose beads.
- Wash Buffers: High-salt buffer, Urea buffer, etc.
- Digestion reagents: DTT, Iodoacetamide, Trypsin.

Procedure:

- Cell Lysis:
 - Harvest labeled and unlabeled control cells.
 - Lyse cell pellets in ice-cold Lysis Buffer (e.g., 1 mL per 10-20 mg of protein).[9]
 - Clarify lysate by centrifugation at 14,000 x g for 15 minutes at 4°C. Determine protein concentration (e.g., BCA assay).
- Click Reaction:

- In a microfuge tube, combine 1-2 mg of protein lysate with the click reaction components.
- Final Concentrations:
 - Protein Lysate: 1-2 mg/mL
 - Biotin-Picolyl Azide: 50-100 μ M
 - Copper(II) Sulfate: 20 μ M
 - THPTA (ligand): 100 μ M
 - Sodium Ascorbate (reductant): 1 mM
- Incubate at room temperature for 30 minutes with gentle rotation.
- Affinity Purification:
 - Pre-wash streptavidin-agarose beads with Lysis Buffer.
 - Add the bead slurry to the completed click reaction mixture.
 - Incubate for 1-2 hours at room temperature to capture biotinylated proteins.
 - Pellet the beads and discard the supernatant.
- Stringent Washing:
 - Perform a series of washes to remove non-specifically bound proteins. This is a critical step.
 - Wash 1: 1x with Lysis Buffer + 1% SDS.
 - Wash 2: 2x with 8 M Urea in 100 mM Tris-HCl, pH 8.0.
 - Wash 3: 2x with 20% Acetonitrile in 100 mM Ammonium Bicarbonate.
 - Wash 4: 3x with 100 mM Ammonium Bicarbonate.

- On-Bead Digestion:
 - Resuspend the washed beads in 100 mM Ammonium Bicarbonate.
 - Reduce proteins with 10 mM DTT for 30 minutes at 56°C.
 - Alkylate with 20 mM Iodoacetamide for 30 minutes at room temperature in the dark.
 - Add sequencing-grade trypsin (e.g., 1:50 enzyme-to-protein ratio) and incubate overnight at 37°C.
- Sample Preparation for MS:
 - Collect the supernatant containing the digested peptides.
 - Acidify the peptides with formic acid to a final concentration of 0.1-1%.
 - Desalt the peptides using a C18 StageTip or equivalent.
 - Elute, dry, and reconstitute in a suitable buffer for LC-MS/MS analysis.

Caption: Workflow for affinity purification using Biotin-Picolyl Azide.

Application: Cross-Linking Mass Spectrometry (XL-MS)

XL-MS is a powerful technique for mapping protein-protein interactions (PPIs) and elucidating the three-dimensional structure of protein complexes. A major challenge in XL-MS is the low abundance of cross-linked peptides, which makes their detection difficult. Incorporating a picolyl azide into a cleavable cross-linker provides a "clickable" handle for the specific enrichment of these informative peptides.[\[10\]](#)[\[11\]](#)

Principle of the Workflow: In this strategy, proteins are cross-linked in vitro or in living cells using a heterobifunctional or homobifunctional cross-linker that contains an alkyne moiety. After cross-linking, the proteins are digested, resulting in a complex mixture of unmodified peptides, monolinked peptides, and the desired cross-linked peptides. This mixture is then subjected to a click reaction with a picolyl azide-functionalized tag (e.g., Dde Biotin Picolyl Azide, which is

cleavable).[12] The high efficiency of the picolyl azide ensures robust tagging of the alkyne-containing cross-linked peptides. These tagged peptides are then enriched, the cleavable linker is broken to release them from the affinity resin, and they are analyzed by MS.

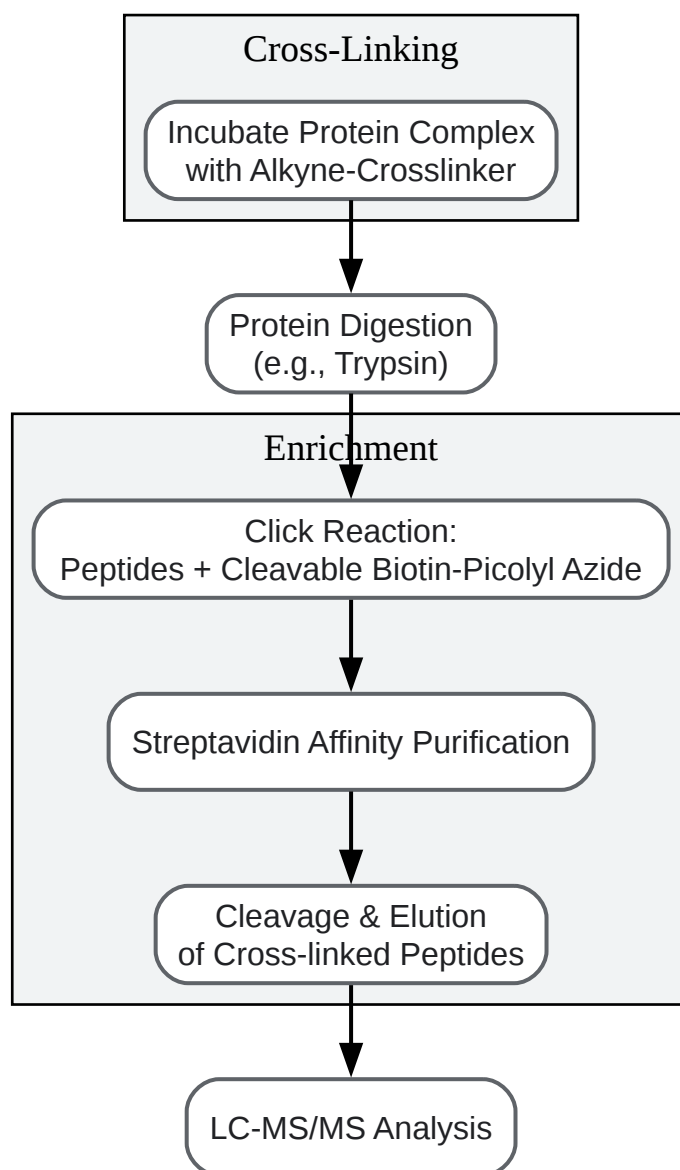

[Click to download full resolution via product page](#)

Caption: Enrichment strategy for XL-MS using a clickable cross-linker.

Protocol: Enrichment of Alkyne-Tagged Cross-Linked Peptides

Trustworthiness: This protocol relies on the specific reaction between the alkyne on the cross-linker and the picolyl azide on the enrichment probe. The subsequent MS data analysis will specifically search for peptide pairs linked by the mass of the cross-linker remnant, providing inherent validation of the workflow.

Materials:

- Cross-linked protein sample (using a cross-linker containing an alkyne handle).
- Digestion reagents (as in section 2.1).
- Cleavable Biotin Picolyl Azide (e.g., Dde Biotin Picolyl Azide).
- Click reaction components (as in section 2.1).
- Streptavidin-agarose beads.
- Cleavage Buffer (e.g., 2% aqueous hydrazine for Dde linkers).[\[12\]](#)

Procedure:

- Protein Digestion:
 - Denature, reduce, and alkylate the cross-linked protein mixture.
 - Perform tryptic digestion overnight at 37°C.
- Click Reaction & Enrichment:
 - Perform the click reaction on the peptide mixture using the Cleavable Biotin-Picolyl Azide probe as described in step 2 of protocol 2.1.
 - Enrich the biotinylated peptides using streptavidin-agarose beads as described in step 3 of protocol 2.1.
 - Perform stringent washes as described in step 4 of protocol 2.1 to ensure a pure sample of cross-linked peptides.

- Cleavage and Elution:
 - After the final wash, resuspend the beads in the appropriate Cleavage Buffer (e.g., 2% hydrazine for a Dde linker).
 - Incubate for 1-2 hours at room temperature to cleave the linker and release the cross-linked peptides from the beads.
 - Pellet the beads and carefully collect the supernatant containing the purified cross-linked peptides.
- Sample Preparation and MS Analysis:
 - Immediately quench the cleavage reaction (e.g., with acetone for hydrazine).
 - Desalt the eluted peptides using a C18 StageTip.
 - Analyze by LC-MS/MS. The data should be analyzed with specialized XL-MS software (e.g., pLink, XlinkX) to identify the cross-linked peptide pairs.

Application: Photo-Affinity Labeling (PAL) for Target Deconvolution

Identifying the protein targets of small molecules is a critical step in drug development. PAL is a powerful technique where a small molecule probe, equipped with a photoreactive group, is used to covalently label its binding partners upon UV irradiation.^{[13][14]} Incorporating a picolyl azide into the PAL probe design creates a versatile tool for the subsequent enrichment and identification of these targets.^[15]

Principle of the Workflow: A trifunctional chemical probe is designed containing: 1) the small molecule of interest to direct binding, 2) a photoreactive group (e.g., diazirine or aryl azide) for covalent capture, and 3) a picolyl azide handle for bioorthogonal ligation.^[16] The probe is incubated with live cells or a cell lysate to allow binding to its protein targets.^[17] UV light is then applied to activate the photoreactive group, forming a covalent bond with the target protein. The lysate is then subjected to a click reaction with an alkyne-functionalized biotin tag. The highly efficient picolyl azide chemistry ensures robust biotinylation of the captured proteins, which can then be enriched and identified by mass spectrometry.

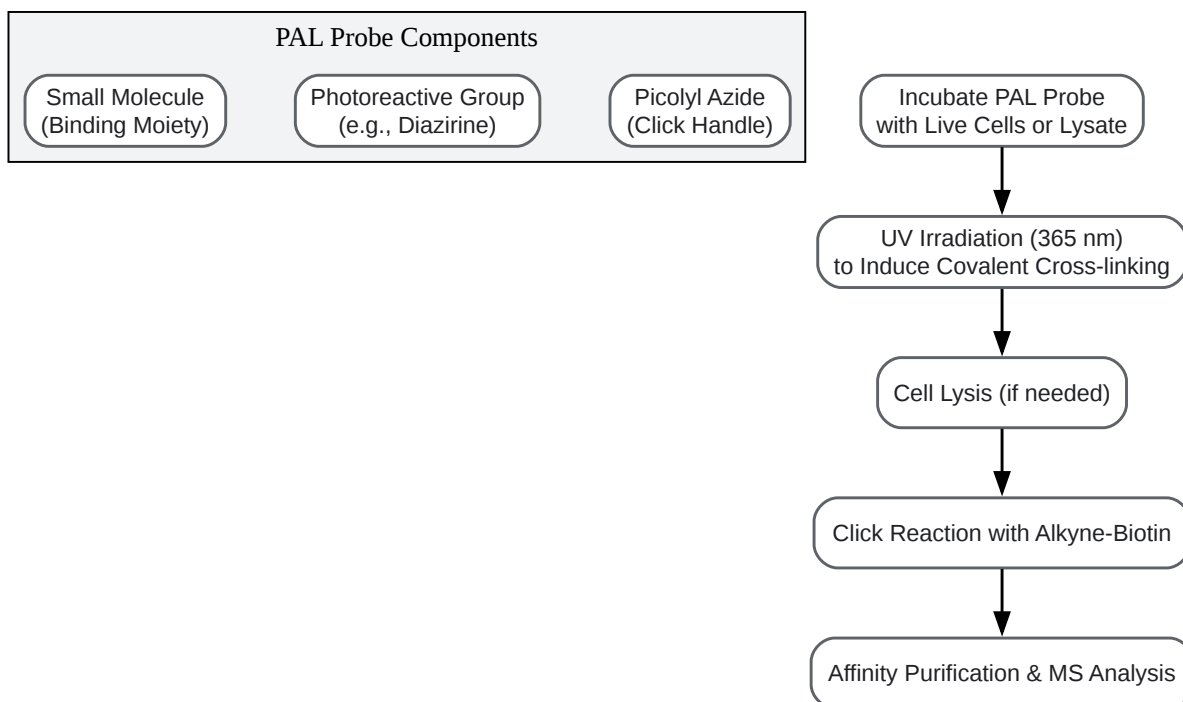

[Click to download full resolution via product page](#)

Caption: Workflow for target identification using a PAL probe.

This protocol follows the same principles for the click reaction, enrichment, and MS analysis outlined in Section 2.1, with the key difference being the initial photo-crosslinking step to capture the protein-small molecule interaction.

Mass Spectrometry and Data Analysis

When analyzing samples prepared with picolyl azide reagents, the primary consideration for mass spectrometry is accounting for the mass modification on the tagged peptides. The triazole ring formed during the click reaction is highly stable and does not typically fragment under standard collision-induced dissociation (CID) or higher-energy collisional dissociation (HCD) conditions.^{[18][19]} Therefore, fragmentation will occur along the peptide backbone as usual.

For data analysis, the mass of the entire tag adduct remaining after digestion (and cleavage, if applicable) must be specified as a variable modification in the database search software (e.g., MaxQuant, Proteome Discoverer, FragPipe). For XL-MS data, specialized software is required to identify peptide pairs connected by the mass of the cross-linker remnant.

References

- Click Chemistry in Proteomic Investigations - PMC. National Center for Biotechnology Information. [\[Link\]](#)
- A comparative study of bioorthogonal reactions with azides - PubMed. National Center for Biotechnology Information. [\[Link\]](#)
- Poly(glycidyl azide) as Photo-Crosslinker for Polymers - MDPI. MDPI. [\[Link\]](#)
- Azide-based bioorthogonal chemistry: Reactions and its advances in cellular and biomolecular imaging - PubMed Central. National Center for Biotechnology Information. [\[Link\]](#)
- Azide-containing Fluorescent Dyes. Jena Bioscience. [\[Link\]](#)
- Applications of Azide-Based Bioorthogonal Click Chemistry in Glycobiology - MDPI. MDPI. [\[Link\]](#)
- A Genetically Encoded Picolyl Azide for Improved Live Cell Copper Click Labeling. ResearchGate. [\[Link\]](#)
- Fast, Cell-compatible Click Chemistry with Copper-chelating Azides for Biomolecular Labeling - PMC. National Center for Biotechnology Information. [\[Link\]](#)
- Di(2-picolyl)amine Appended Luminescent Probes : Advances in Bioimaging and Therapeutics | Request PDF. ResearchGate. [\[Link\]](#)
- A Genetically Encoded Picolyl Azide for Improved Live Cell Copper Click Labeling - Frontiers. Frontiers. [\[Link\]](#)
- Developing a new cleavable crosslinker reagent for in-cell crosslinking - PMC. National Center for Biotechnology Information. [\[Link\]](#)

- Small Molecule Interactome Mapping by Photo-Affinity Labeling (SIM-PAL) to Identify Binding Sites of Small Molecules on a Proteome-Wide Scale. ResearchGate. [\[Link\]](#)
- Selective Enrichment and Identification of Azide-tagged Cross-linked Peptides Using Chemical Ligation and Mass Spectrometry - NIH. National Center for Biotechnology Information. [\[Link\]](#)
- Picolinyl ester fragmentation mechanism studies with application to the identification of acylcarnitine acyl groups following transesterification - PubMed. National Center for Biotechnology Information. [\[Link\]](#)
- Photolytic Labeling and Its Applications in Protein Drug Discovery and Development - NIH. National Center for Biotechnology Information. [\[Link\]](#)
- Selective Enrichment of Azide-Containing Peptides from Complex Mixtures - PMC. National Center for Biotechnology Information. [\[Link\]](#)
- Preanalytical Strategies for Native Mass Spectrometry Analysis of Protein Modifications, Complexes, and Higher-Order Structures - MDPI. MDPI. [\[Link\]](#)
- Cleavable Biotin Probes for Labeling of Biomolecules via the Azide – Alkyne Cycloaddition. National Center for Biotechnology Information. [\[Link\]](#)
- Mass spectrometry of aryl azides - ResearchGate. ResearchGate. [\[Link\]](#)
- Use of aryl azide cross-linkers to investigate protein-protein interactions - PubMed. National Center for Biotechnology Information. [\[Link\]](#)
- Photoaffinity labeling in target- and binding-site identification - PMC. National Center for Biotechnology Information. [\[Link\]](#)
- Strategies for Acid and Amine Cross-linking and Labeling for Protein Structural Characterization Using Mass Spectrometry - PMC. National Center for Biotechnology Information. [\[Link\]](#)
- Mass Spectrometry: Fragmentation Mechanisms - YouTube. YouTube. [\[Link\]](#)

- Site-specific protein labeling using PRIME and chelation-assisted click chemistry - PubMed. National Center for Biotechnology Information. [[Link](#)]
- Why azide agarose beads give a poor enrichment efficiency of alkyne tagged protein? ResearchGate. [[Link](#)]
- Single-Sequence Identification of Modified Peptides: A One-Pot Method Using Homologous Biotinyl Azides. ChemRxiv. [[Link](#)]
- Targeting the Reactive Proteome: Recent Advances in Activity-Based Protein Profiling and Probe Design - MDPI. MDPI. [[Link](#)]
- Photoaffinity labelling with small molecules. OUCI. [[Link](#)]
- Synthesis of Two New Enrichable and MS-Cleavable Cross-linkers to Define Protein-Protein Interactions by Mass Spectrometry - PubMed Central. National Center for Biotechnology Information. [[Link](#)]
- Mass Spectrometry - Fragmentation Patterns - Chemistry LibreTexts. Chemistry LibreTexts. [[Link](#)]
- Live-cell Photoaffinity Labeling: Binding Proteins (Native Environment) - YouTube. YouTube. [[Link](#)]
- CHAPTER 2 Fragmentation and Interpretation of Spectra 2.1 Introduction. University of Arizona. [[Link](#)]

Need Custom Synthesis?

BenchChem offers custom synthesis for rare earth carbides and specific isotopic labeling.

Email: info@benchchem.com or [Request Quote Online](#).

Sources

- [1. Azide-based bioorthogonal chemistry: Reactions and its advances in cellular and biomolecular imaging - PMC \[pmc.ncbi.nlm.nih.gov\]](#)

- [2. mdpi.com \[mdpi.com\]](https://www.mdpi.com)
- [3. A comparative study of bioorthogonal reactions with azides - PubMed \[pubmed.ncbi.nlm.nih.gov\]](https://pubmed.ncbi.nlm.nih.gov/)
- [4. Click Chemistry in Proteomic Investigations - PMC \[pmc.ncbi.nlm.nih.gov\]](https://pubmed.ncbi.nlm.nih.gov/)
- [5. Fast, Cell-compatible Click Chemistry with Copper-chelating Azides for Biomolecular Labeling - PMC \[pmc.ncbi.nlm.nih.gov\]](https://pubmed.ncbi.nlm.nih.gov/)
- [6. vectorlabs.com \[vectorlabs.com\]](https://www.vectorlabs.com)
- [7. vectorlabs.com \[vectorlabs.com\]](https://www.vectorlabs.com)
- [8. biotium.com \[biotium.com\]](https://www.biotium.com)
- [9. vectorlabs.com \[vectorlabs.com\]](https://www.vectorlabs.com)
- [10. Developing a new cleavable crosslinker reagent for in-cell crosslinking - PMC \[pmc.ncbi.nlm.nih.gov\]](https://pubmed.ncbi.nlm.nih.gov/)
- [11. Selective Enrichment and Identification of Azide-tagged Cross-linked Peptides Using Chemical Ligation and Mass Spectrometry - PMC \[pmc.ncbi.nlm.nih.gov\]](https://pubmed.ncbi.nlm.nih.gov/)
- [12. vectorlabs.com \[vectorlabs.com\]](https://www.vectorlabs.com)
- [13. Photolytic Labeling and Its Applications in Protein Drug Discovery and Development - PMC \[pmc.ncbi.nlm.nih.gov\]](https://pubmed.ncbi.nlm.nih.gov/)
- [14. Photoaffinity labeling in target- and binding-site identification - PMC \[pmc.ncbi.nlm.nih.gov\]](https://pubmed.ncbi.nlm.nih.gov/)
- [15. researchgate.net \[researchgate.net\]](https://www.researchgate.net)
- [16. Photoreactive Crosslinker Chemistry | Thermo Fisher Scientific - DE \[thermofisher.com\]](https://www.thermofisher.com)
- [17. youtube.com \[youtube.com\]](https://www.youtube.com)
- [18. Picolinyl ester fragmentation mechanism studies with application to the identification of acylcarnitine acyl groups following transesterification - PubMed \[pubmed.ncbi.nlm.nih.gov\]](https://pubmed.ncbi.nlm.nih.gov/)
- [19. researchgate.net \[researchgate.net\]](https://www.researchgate.net)
- To cite this document: BenchChem. [Application Notes & Protocols: Picolyl-azide-NH₂ in Advanced Proteomics and Mass Spectrometry]. BenchChem, [2026]. [Online PDF]. Available at: [<https://www.benchchem.com/product/b14802606/docs#application-notes-protocols-picolyl-azide-nh2-in-advanced-proteomics-and-mass-spectrometry>]

Disclaimer & Data Validity:

The information provided in this document is for Research Use Only (RUO) and is strictly not intended for diagnostic or therapeutic procedures. While BenchChem strives to provide accurate protocols, we make no warranties, express or implied, regarding the fitness of this product for every specific experimental setup.

Technical Support: The protocols provided are for reference purposes. Unsure if this reagent suits your experiment?

Need Industrial/Bulk Grade? [Request Custom Synthesis Quote](#)

BenchChem

Our mission is to be the trusted global source of essential and advanced chemicals, empowering scientists and researchers to drive progress in science and industry.

Contact

Address: 3281 E Guasti Rd
Ontario, CA 91761, United States
Phone: (601) 213-4426
Email: info@benchchem.com

[Contact our Ph.D. Support Team for a compatibility check](#)