

Assaying GPI-Mannosyltransferase II (PIG-V) Activity In Vitro: Application Notes and Protocols

Author: BenchChem Technical Support Team. **Date:** December 2025

Compound of Interest

Compound Name: *Pga1*

Cat. No.: *B148677*

[Get Quote](#)

For Researchers, Scientists, and Drug Development Professionals

Introduction

Glycosylphosphatidylinositol (GPI)-mannosyltransferase II (GPI-MT-II), encoded by the PIGV gene, is a critical enzyme in the biosynthetic pathway of GPI anchors.[1][2] GPI anchors are complex glycolipids that attach a wide variety of proteins to the cell surface in eukaryotes. This post-translational modification is essential for the proper function and localization of these GPI-anchored proteins, which play roles in cell adhesion, signaling, and immune responses.[3] GPI-MT-II catalyzes the transfer of the second mannose residue from dolichol-phosphate-mannose (Dol-P-Man) to the growing GPI precursor, specifically to Man-GlcN-(acyl)PI, forming Man-Man-GlcN-(acyl)PI.[3][4] Dysregulation of the GPI biosynthesis pathway has been implicated in various diseases, making the enzymes in this pathway, including GPI-MT-II, potential therapeutic targets.

These application notes provide detailed protocols for assaying the in vitro activity of GPI-MT-II. The included methodologies cover the preparation of the enzyme source, the synthesis of the necessary substrates, and both radiolabeled and conceptual non-radioactive detection methods. This document is intended to serve as a comprehensive guide for researchers investigating the function of GPI-MT-II and for professionals in drug development screening for potential inhibitors.

Biochemical Pathway and Experimental Workflow

The GPI biosynthesis pathway is a sequential process occurring in the endoplasmic reticulum. GPI-MT-II acts at a specific step to elongate the glycan core of the GPI anchor.

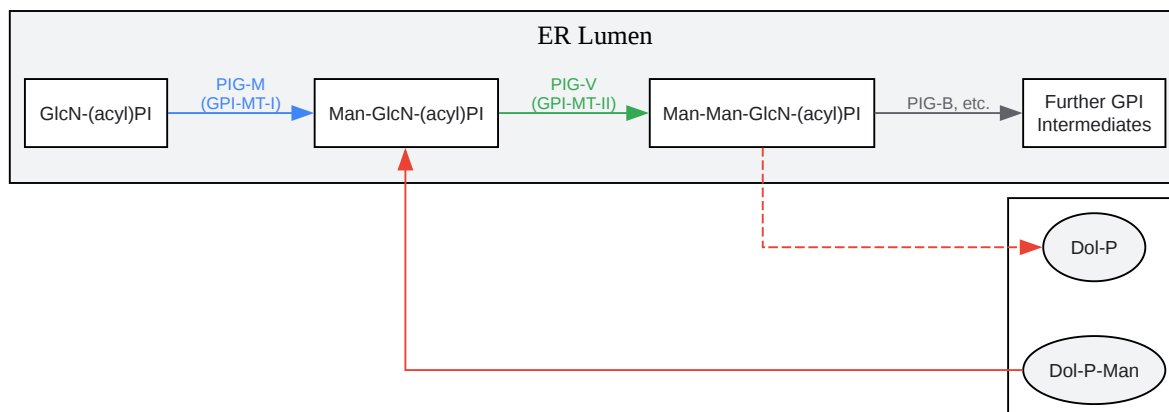

[Click to download full resolution via product page](#)

Caption: Simplified GPI biosynthesis pathway focusing on GPI-MT-II (PIG-V).

The general workflow for an in vitro GPI-MT-II assay involves the preparation of the enzyme and substrates, the enzymatic reaction, and subsequent detection of the product.

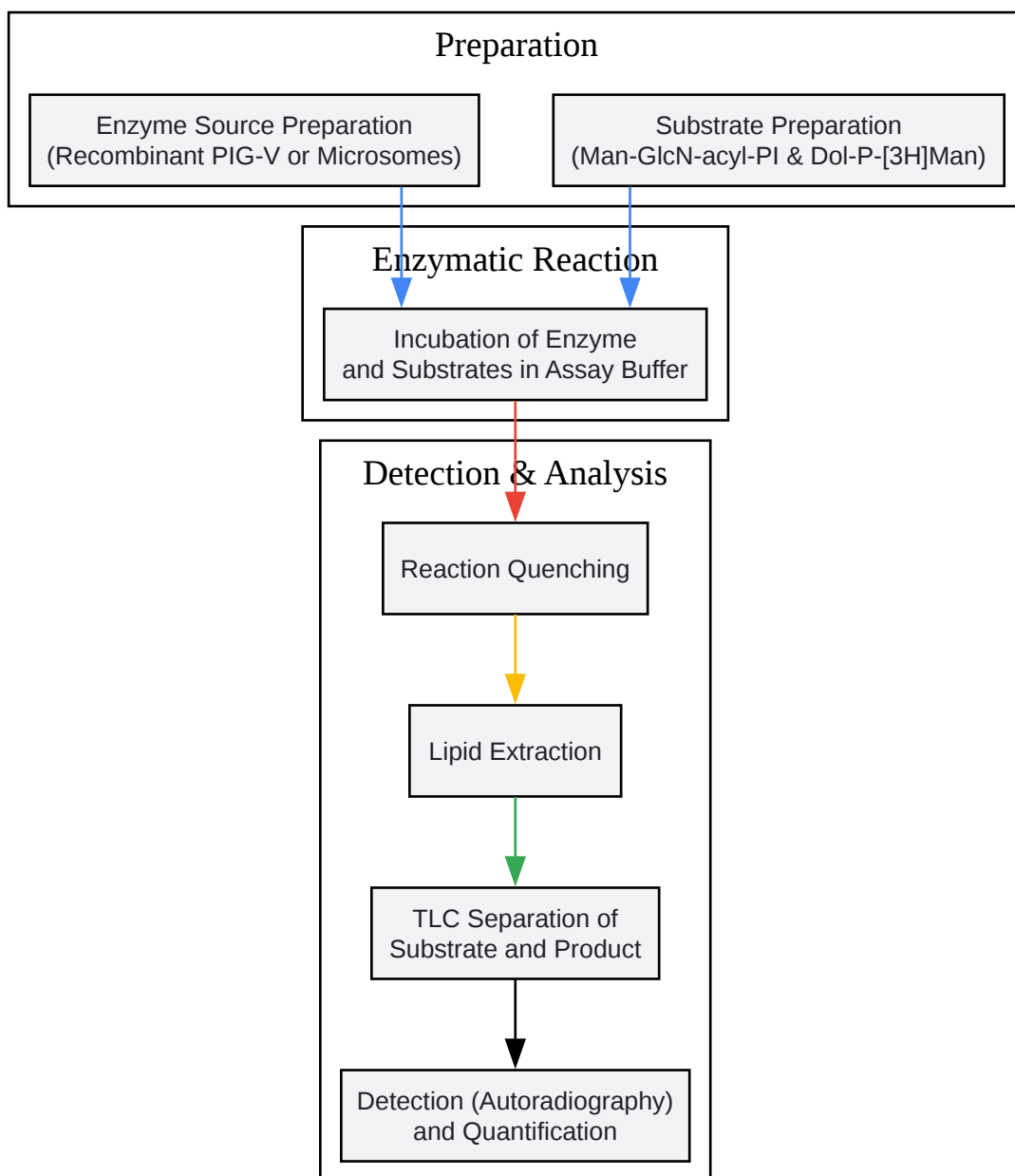

[Click to download full resolution via product page](#)

Caption: General experimental workflow for the in vitro GPI-MT-II assay.

Experimental Protocols

Protocol 1: Preparation of Enzyme Source - Microsomes from PI3-V Overexpressing Cells

This protocol describes the preparation of microsomes, which are enriched in endoplasmic reticulum-resident enzymes like GPI-MT-II.

Materials:

- Cell line overexpressing PIG-V (e.g., HEK293 or CHO cells)
- Phosphate-buffered saline (PBS), ice-cold
- Homogenization buffer (250 mM sucrose, 10 mM HEPES-NaOH pH 7.4, 1 mM DTT, and protease inhibitors), ice-cold[5]
- Dounce homogenizer
- Ultracentrifuge

Procedure:

- Culture PIG-V overexpressing cells to a high density.
- Harvest cells by centrifugation and wash twice with ice-cold PBS.
- Resuspend the cell pellet in ice-cold homogenization buffer.
- Homogenize the cells on ice using a Dounce homogenizer until approximately 80-90% of cells are lysed, as monitored by microscopy.
- Centrifuge the homogenate at 10,000 x g for 15 minutes at 4°C to pellet nuclei and unbroken cells.[4]
- Carefully collect the supernatant and transfer it to a fresh ultracentrifuge tube.
- Centrifuge the supernatant at 100,000 x g for 1 hour at 4°C to pellet the microsomal fraction. [6]
- Discard the supernatant and resuspend the microsomal pellet in a minimal volume of homogenization buffer.

- Determine the protein concentration of the microsomal preparation using a standard protein assay (e.g., BCA assay).
- Aliquot the microsomes, snap-freeze in liquid nitrogen, and store at -80°C until use.

Protocol 2: In Vitro GPI-Mannosyltransferase II Assay (Radiolabeled)

This protocol details a radioactive assay to measure the activity of GPI-MT-II by monitoring the transfer of radiolabeled mannose.

Materials:

- Microsomal preparation containing PIG-V (from Protocol 1)
- Man-GlcN-acyl-PI (acceptor substrate)
- Dolichol-phosphate-[³H]mannose (Dol-P-[³H]Man; radiolabeled donor substrate)
- Assay Buffer (50 mM HEPES-NaOH pH 7.4, 25 mM KCl, 5 mM MgCl₂, 5 mM MnCl₂)[7]
- Tunicamycin (to inhibit N-linked glycosylation)
- Chloroform/Methanol (2:1, v/v)
- TLC plates (Silica Gel 60)
- TLC solvent system (e.g., Chloroform/Methanol/Water in a 65:25:4 ratio)[8]
- Scintillation counter

Procedure:

- Prepare the reaction mixture in a microcentrifuge tube on ice. For a standard 50 µL reaction, combine:
 - Assay Buffer

- Man-GlcN-acyl-PI (final concentration to be optimized, typically in the low μM range)
- Tunicamycin (final concentration $\sim 5 \mu\text{g/mL}$)
- Microsomal preparation (20-50 μg of protein)
- Pre-incubate the mixture at 37°C for 5 minutes.
- Initiate the reaction by adding Dol-P- $^{3\text{H}}$ Man (final concentration to be optimized, with a specific activity of $\sim 1\text{-}5 \mu\text{Ci}$ per reaction).
- Incubate the reaction at 37°C for a specified time (e.g., 30-60 minutes).
- Stop the reaction by adding 500 μL of chloroform/methanol (2:1).
- Vortex thoroughly and centrifuge to separate the phases.
- Collect the lower organic phase containing the lipids and dry it under a stream of nitrogen.
- Resuspend the dried lipid extract in a small volume of chloroform/methanol (2:1).
- Spot the extract onto a TLC plate and develop the chromatogram using the chosen solvent system.
- After development, dry the TLC plate and visualize the radiolabeled lipids by autoradiography or a phosphorimager.
- Identify the spots corresponding to the substrate (unreacted Dol-P- $^{3\text{H}}$ Man) and the product (Man-Man-GlcN-acyl-PI).
- Scrape the silica from the product spot into a scintillation vial, add scintillation fluid, and quantify the radioactivity using a scintillation counter.

Protocol 3: Non-Radioactive GPI-Mannosyltransferase II Assay (Conceptual Framework)

A non-radioactive assay would enhance safety and convenience. Below is a conceptual framework for developing such an assay using a fluorescently labeled donor substrate.

Principle: This assay would utilize a dolichol-phosphate-mannose analog conjugated to a fluorescent dye (e.g., NBD or a Bodipy dye). The transfer of the fluorescent mannose to the acceptor substrate would be detected by a change in the physical properties of the fluorescent product, allowing for separation and quantification.

Conceptual Workflow:

- **Synthesis of Fluorescent Donor:** Synthesize Dol-P-Man with a fluorescent tag.
- **Enzymatic Reaction:** Perform the enzymatic reaction as described in Protocol 2, replacing Dol-P-[³H]Man with the fluorescently labeled Dol-P-Man.
- **Separation and Detection:**
 - **Option A: TLC with Fluorescence Imaging:** Separate the fluorescent product from the fluorescent substrate by TLC and quantify the fluorescence of the product spot using a fluorescence imager.
 - **Option B: HPLC with Fluorescence Detection:** Separate the reaction components by HPLC and quantify the product using an in-line fluorescence detector.
 - **Option C: FRET-based Assay:** Design a FRET (Förster Resonance Energy Transfer) system where the acceptor substrate (Man-GlcN-acyl-PI) is labeled with an acceptor fluorophore. The transfer of the donor-labeled mannose would bring the two fluorophores into proximity, resulting in a FRET signal.

Data Presentation

Quantitative data from GPI-MT-II assays should be presented in a clear and organized manner to facilitate comparison and interpretation.

Table 1: Hypothetical Kinetic Parameters for GPI-MT-II

Substrate	K _m (μM)	V _{max} (pmol/min/mg)
Dol-P-Man	5.2	150
Man-GlcN-acyl-PI	2.8	145

Note: These are hypothetical values for illustrative purposes. Actual values must be determined experimentally.

Table 2: Hypothetical IC₅₀ Values of Inhibitors for GPI-MT-II

Inhibitor	IC ₅₀ (μM)
Mannosamine	85
Compound X	12.5

Note: These are hypothetical values for illustrative purposes. Actual values must be determined experimentally.

Conclusion

The protocols and guidelines presented here provide a comprehensive framework for the in vitro assessment of GPI-mannosyltransferase II activity. The successful implementation of these assays will enable a deeper understanding of the enzymatic mechanism of PIG-V and facilitate the discovery and characterization of novel inhibitors with therapeutic potential. While the radiolabeled assay is a well-established and sensitive method, the development of a robust non-radioactive alternative would represent a significant advancement in the field.

Need Custom Synthesis?

BenchChem offers custom synthesis for rare earth carbides and specific isotopic labeling.

Email: info@benchchem.com or [Request Quote Online](#).

References

- 1. uniprot.org [uniprot.org]
- 2. svineproduktion.dk [svineproduktion.dk]
- 3. ab :: Animal Bioscience [animbiosci.org]
- 4. [Preparation of mouse liver microsome]:Glycoscience Protocol Online Database [jcgddb.jp]

- 5. [mdpi.com](https://www.mdpi.com) [[mdpi.com](https://www.mdpi.com)]
- 6. Thawing and Incubating Human and Animal Liver Microsomes | Thermo Fisher Scientific - SG [[thermofisher.com](https://www.thermofisher.com)]
- 7. Development and application of a multi-step porcine in vitro system to evaluate feedstuffs and feed additives for their efficacy in nutrient digestion, digesta characteristics, and intestinal immune responses - PMC [[pmc.ncbi.nlm.nih.gov](https://pubmed.ncbi.nlm.nih.gov)]
- 8. [avantiresearch.com](https://www.avantiresearch.com) [[avantiresearch.com](https://www.avantiresearch.com)]
- To cite this document: BenchChem. [Assaying GPI-Mannosyltransferase II (PIG-V) Activity In Vitro: Application Notes and Protocols]. BenchChem, [2025]. [Online PDF]. Available at: [<https://www.benchchem.com/product/b148677#assaying-gpi-mannosyltransferase-ii-activity-in-vitro>]

Disclaimer & Data Validity:

The information provided in this document is for Research Use Only (RUO) and is strictly not intended for diagnostic or therapeutic procedures. While BenchChem strives to provide accurate protocols, we make no warranties, express or implied, regarding the fitness of this product for every specific experimental setup.

Technical Support: The protocols provided are for reference purposes. Unsure if this reagent suits your experiment? [[Contact our Ph.D. Support Team for a compatibility check](#)]

Need Industrial/Bulk Grade? [Request Custom Synthesis Quote](#)

BenchChem

Our mission is to be the trusted global source of essential and advanced chemicals, empowering scientists and researchers to drive progress in science and industry.

Contact

Address: 3281 E Guasti Rd
Ontario, CA 91761, United States
Phone: (601) 213-4426
Email: info@benchchem.com