

Evaluation Guide: Ternary Complex Stability with PEG6 Linkers in PROTAC Design

Author: BenchChem Technical Support Team. **Date:** April 2026

Compound of Interest

Compound Name: *BocNH-PEG6-acid*

Cat. No.: *B14795183*

[Get Quote](#)

Executive Summary

In Targeted Protein Degradation (TPD), the linker is not merely a passive connector; it is a thermodynamic lever that dictates the stability of the ternary complex (

). Polyethylene Glycol chains of 6 units (PEG6) have emerged as a "Goldilocks" standard in early-stage discovery—offering a fully extended length of ~25–30 Å that accommodates a wide range of E3-target distances while maintaining aqueous solubility.

This guide provides a technical framework for evaluating the stability of ternary complexes formed by PEG6-linked PROTACs. It contrasts PEG6 with alkyl and rigid alternatives and details the biophysical protocols (SPR and TR-FRET) required to quantify cooperativity (

).

Scientific Rationale: The Thermodynamics of PEG6

The formation of the ternary complex is governed by the cooperativity factor (

), defined as the ratio of binary to ternary dissociation constants: [1]

- (Positive Cooperativity): The PROTAC creates de novo protein-protein interactions (PPIs) between the E3 ligase and the Protein of Interest (POI).
- (Negative Cooperativity): Steric clashes or entropic penalties destabilize the complex.

Why PEG6? PEG6 provides a high degree of conformational freedom. While this incurs an entropic penalty upon binding (freezing a floppy chain), its hydrophilicity prevents the linker from collapsing into hydrophobic pockets, which often plagues alkyl chains.[2] Evaluating PEG6 involves determining if this entropic cost is outweighed by the favorable enthalpy of bringing the proteins together without steric clash.

Mechanism of Action

The following diagram illustrates the equilibrium states involved in evaluating ternary complex stability.

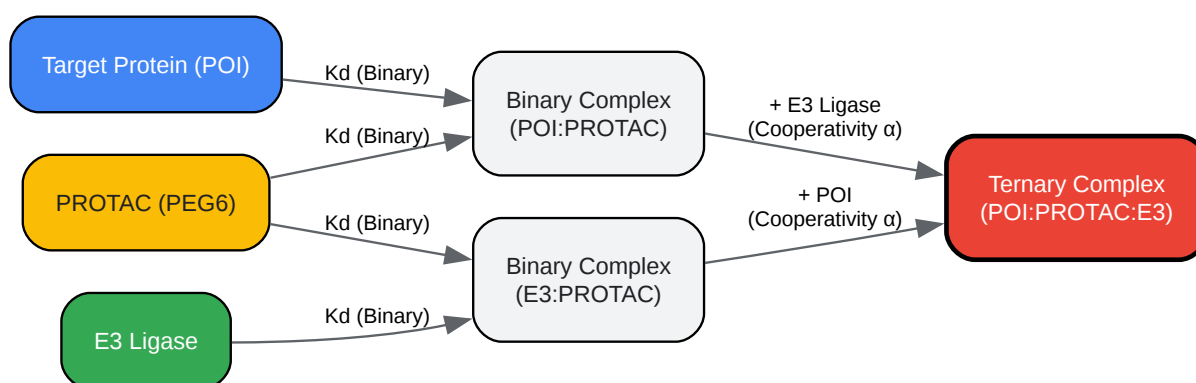

[Click to download full resolution via product page](#)

Figure 1: Thermodynamic equilibria in PROTAC-mediated ternary complex formation. The stability of the final red node (Ternary) relative to the grey nodes (Binary) determines the cooperativity factor (

).

Comparative Analysis: PEG6 vs. Alternatives

When evaluating PEG6, it is critical to benchmark its performance against distinct linker classes to understand the structural-activity relationship (SAR).

Linker Class	Physicochemical Profile	vs. PEG6 Performance	Primary Failure Mode
PEG6 (Benchmark)	Hydrophilic, Flexible (~26Å)	Baseline. High solubility; moderate permeability.	High entropy penalty (floppy); oxidative instability.
Short PEG (PEG2-4)	Hydrophilic, Constrained	Higher Cooperativity (Potential). If geometry allows, reduced entropy loss leads to tighter binding.	Steric Clash. Too short to bridge the gap, preventing complex formation ().
Alkyl Chains (C6-C10)	Hydrophobic, Flexible	Better Permeability. Often shows higher cellular potency despite similar due to membrane crossing.	Solubility. Aggregation in assay buffer; "greasy" linker collapses into protein pockets.
Rigid Linkers (Piperazine/Proline)	Rigid, Defined Geometry	Maximum Cooperativity. Locks the complex in a productive conformation.	Geometry Mismatch. Requires precise structural modeling; if the angle is wrong, binding is abolished.

Key Insight: Use PEG6 as a "scanner." If PEG6 works but has low potency, switch to rigid linkers to improve thermodynamics. If PEG6 fails to form a ternary complex, the E3-POI distance likely exceeds 30Å, or steric clashes are severe.

Experimental Protocols for Stability Evaluation

To rigorously evaluate PEG6 stability, you must move beyond simple degradation assays () and measure physical binding kinetics.

Protocol A: Surface Plasmon Resonance (SPR) – The Gold Standard

SPR allows the direct measurement of

,
, and residence time (
) of the ternary complex.

Workflow:

- Immobilization: Immobilize the E3 Ligase (e.g., VHL or CRBN) on a CM5 or Streptavidin chip. Target density: ~1000 RU to avoid mass transport limitations.
- Binary Check: Inject PROTAC (PEG6) alone at increasing concentrations. Calculate [. \[2\]\[3\]\[4\]](#)
- Ternary Injection: Saturate the PROTAC solution with the POI (Target Protein) at a concentration [. \[2\]\[3\]\[4\]](#). Inject this mixture over the immobilized E3.
- Analysis: Fit the sensorgram to a 1:1 binding model. The resulting affinity is [. \[4\]](#)

Calculation:

Protocol B: TR-FRET Hook Effect Assay

High-throughput validation of ternary complex existence. [\[5\]](#)

Workflow:

- Labeling: Label E3 ligase with a Donor fluorophore (e.g., Terbium) and POI with an Acceptor (e.g., FITC or Alexa488).

- Titration: Titrate PEG6-PROTAC (0.1 nM to 10 μ M) into a mixture of fixed E3 and POI.
- Readout: Measure FRET signal.
- Interpretation: Look for the "Hook Effect" (Bell-shaped curve).^[5]
 - Rising Edge: Formation of Ternary Complex.^{[1][2][3][4][5][6][7][8][9][10][11][12]}
 - Peak: Optimal stoichiometry.
 - Falling Edge: Formation of separate binary complexes (PROTAC-E3 and PROTAC-POI) competing with each other.

Experimental Workflow Diagram

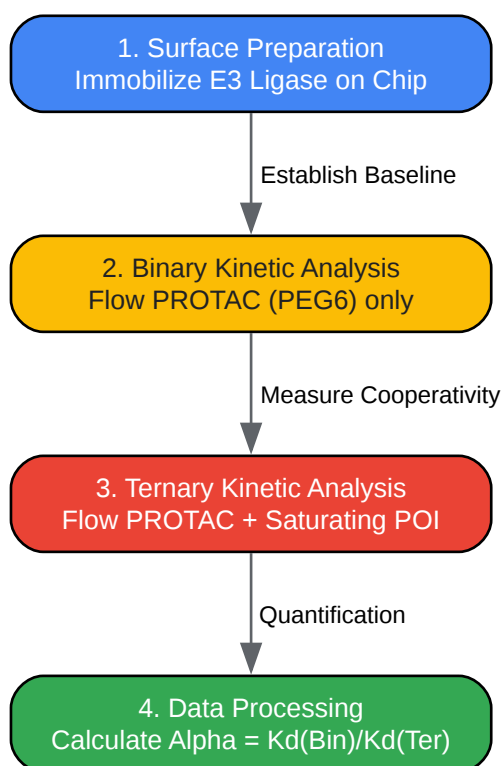

[Click to download full resolution via product page](#)

Figure 2: Step-by-step SPR workflow for quantifying ternary complex cooperativity.

Data Presentation: Representative Evaluation Matrix

When publishing or presenting your PEG6 evaluation, structure your data to highlight the disconnect between affinity and degradation.

Compound	Linker	(nM)	(nM)	Cooperativity ()	(nM)	Interpretation
Cmpd-A	PEG6	150	50	3.0	25	Stable & Potent. Positive cooperativity drives degradation.
Cmpd-B	PEG2	150	600	0.25	>1000	Steric Clash. Linker too short; negative cooperativity.
Cmpd-C	Alkyl-C8	140	60	2.3	10	Permeability Driver. Similar stability to PEG6, but better cell entry.
Cmpd-D	PEG12	150	150	1.0	200	Entropy Penalty. No cooperativity; linker too floppy to stabilize complex.

Note: Data is representative of typical trends seen in VHL-BRD4 or CRBN-POI systems.

References

- Troup, R. I., et al. (2020). Current strategies for the design of PROTAC linkers: a critical review. Exploration of Targeted Anti-tumor Therapy.[2] [Link](#)
- Roy, M. J., et al. (2019). SPR-Measured Dissociation Kinetics of PROTAC Ternary Complexes Influence Target Degradation Rate.[1] ACS Chemical Biology. [Link](#)
- BenchChem. (2025).[2][5][6][7][8][11] Bridging the Gap: A Comparative Guide to PEG and Alkyl Linkers in PROTACs.[Link](#)
- Burslem, G. M., et al. (2018).[8] Small-Molecule Proteolysis-Targeting Chimeras (PROTACs) that Selectively Degrade Cancer-Associated Proteins. Journal of Medicinal Chemistry.[8] [Link](#)
- Cisbio/Revvity.PROTAC Ternary Complex Formation Assays (TR-FRET).[Link](#)

Need Custom Synthesis?

BenchChem offers custom synthesis for rare earth carbides and specific isotopic labeling.

Email: info@benchchem.com or [Request Quote Online](#).

Sources

- 1. SPR-Measured Dissociation Kinetics of PROTAC Ternary Complexes Influence Target Degradation Rate - PMC [[pmc.ncbi.nlm.nih.gov](https://pubmed.ncbi.nlm.nih.gov/)]
- 2. pdf.benchchem.com [pdf.benchchem.com]
- 3. aragen.com [aragen.com]
- 4. o2hdiscovery.co [o2hdiscovery.co]
- 5. pdf.benchchem.com [pdf.benchchem.com]
- 6. pdf.benchchem.com [pdf.benchchem.com]
- 7. pdf.benchchem.com [pdf.benchchem.com]

- [8. pdf.benchchem.com \[pdf.benchchem.com\]](#)
- [9. chempep.com \[chempep.com\]](#)
- [10. benchchem.com \[benchchem.com\]](#)
- [11. pdf.benchchem.com \[pdf.benchchem.com\]](#)
- [12. researchgate.net \[researchgate.net\]](#)
- To cite this document: BenchChem. [Evaluation Guide: Ternary Complex Stability with PEG6 Linkers in PROTAC Design]. BenchChem, [2026]. [Online PDF]. Available at: [<https://www.benchchem.com/product/b14795183/docs#evaluation-guide-ternary-complex-stability-with-peg6-linkers-in-protac-design>]

Disclaimer & Data Validity:

The information provided in this document is for Research Use Only (RUO) and is strictly not intended for diagnostic or therapeutic procedures. While BenchChem strives to provide accurate protocols, we make no warranties, express or implied, regarding the fitness of this product for every specific experimental setup.

Technical Support: The protocols provided are for reference purposes. Unsure if this reagent suits your experiment?

Need Industrial/Bulk Grade? [Request Custom Synthesis Quote](#)

BenchChem

Our mission is to be the trusted global source of essential and advanced chemicals, empowering scientists and researchers to drive progress in science and industry.

Contact

Address: 3281 E Guasti Rd

Ontario, CA 91761, United States

Phone: (601) 213-4426

Email: info@benchchem.com

Contact our Ph.D. Support Team for a compatibility check