

One-Pot Synthesis of Polysubstituted Piperidines: A Senior Application Scientist's Guide

Author: BenchChem Technical Support Team. **Date:** May 2026

Compound of Interest

Compound Name: 3,5-Difluoro-3-methylpiperidin-4-ol

Cat. No.: B14785948

[Get Quote](#)

Introduction: The Enduring Significance of the Piperidine Scaffold

The piperidine ring, a six-membered nitrogen-containing heterocycle, is a cornerstone of medicinal chemistry and natural product synthesis.^[1] Its prevalence in FDA-approved drugs is a testament to its ability to confer favorable pharmacokinetic and pharmacodynamic properties.^[2] Polysubstituted piperidines, in particular, offer a three-dimensional architecture that allows for precise spatial orientation of functional groups, enabling high-affinity interactions with biological targets.^[3] This guide provides an in-depth exploration of modern one-pot synthetic methodologies for accessing these valuable scaffolds, with a focus on the underlying principles, practical applications, and detailed experimental protocols for researchers at the forefront of drug discovery and development.

Multi-Component Reactions (MCRs): A Paradigm of Synthetic Efficiency

Multi-component reactions, wherein three or more reactants combine in a single operation to form a product that incorporates all or most of the starting materials, represent a highly efficient and atom-economical approach to complex molecule synthesis.[4]

The Hantzsch Dihydropyridine Synthesis and its Analogs

First described in 1881, the Hantzsch synthesis is a classic MCR for the preparation of dihydropyridines, which can be readily oxidized to the corresponding pyridines or reduced to piperidines.[5] The archetypal reaction involves the condensation of an aldehyde, two equivalents of a β -ketoester, and a nitrogen source, typically ammonia or ammonium acetate.

Causality in Experimental Choices: The choice of catalyst is crucial in the Hantzsch reaction to ensure good yields and mild reaction conditions. While the original synthesis often required harsh conditions, modern variations employ a range of catalysts, from nano-crystalline solid acids to organocatalysts, to improve efficiency and broaden the substrate scope.[6][7]

Experimental Protocol: One-Pot Synthesis of a Polysubstituted Piperidine via a Hantzsch-type Reaction

This protocol describes a solvent-free, catalyst-mediated Hantzsch-type reaction to form a dihydropyridine, which can be subsequently reduced to the corresponding piperidine.

Materials:

- Aromatic aldehyde (1 mmol)
- Ethyl acetoacetate (2 mmol)
- Ammonium acetate (2 mmol)
- γ -Alumina nanoparticles (0.2 g)[7]
- Ethanol (for recrystallization)
- Palladium on carbon (Pd/C, 10 mol%) (for optional reduction step)

- Hydrogen gas supply (for optional reduction step)

Procedure:

- In a round-bottom flask, combine the aromatic aldehyde (1 mmol), ethyl acetoacetate (2 mmol), ammonium acetate (2 mmol), and γ -alumina nanoparticles (0.2 g).
- Heat the mixture in an oil bath at 90°C under solvent-free conditions, monitoring the reaction progress by Thin Layer Chromatography (TLC).
- Upon completion, cool the reaction mixture to room temperature.
- Add ethyl acetate and filter to remove the catalyst.
- Wash the filtrate with brine, dry over anhydrous Na₂SO₄, and concentrate under reduced pressure.
- Purify the crude dihydropyridine product by recrystallization from hot ethanol.
- (Optional Reduction to Piperidine): Dissolve the purified dihydropyridine in ethanol, add 10 mol% Pd/C, and subject the mixture to hydrogenation (balloon or Parr apparatus) until the reaction is complete (monitored by TLC or GC-MS).
- Filter the reaction mixture through Celite® to remove the catalyst and concentrate the filtrate to obtain the polysubstituted piperidine.

Data Presentation: Substrate Scope of a Hantzsch-type Reaction

Entry	Aldehyde	β -Ketoester	Amine	Yield (%)	Reference
1	Benzaldehyde	Ethyl acetoacetate	Ammonium acetate	92	[7]
2	4-Chlorobenzaldehyde	Ethyl acetoacetate	Ammonium acetate	95	[7]
3	4-Nitrobenzaldehyde	Methyl acetoacetate	Ammonium acetate	90	[8]
4	4-Methoxybenzaldehyde	Ethyl acetoacetate	Ammonium acetate	88	[7]

Visualization: Generalized Hantzsch Dihydropyridine Synthesis

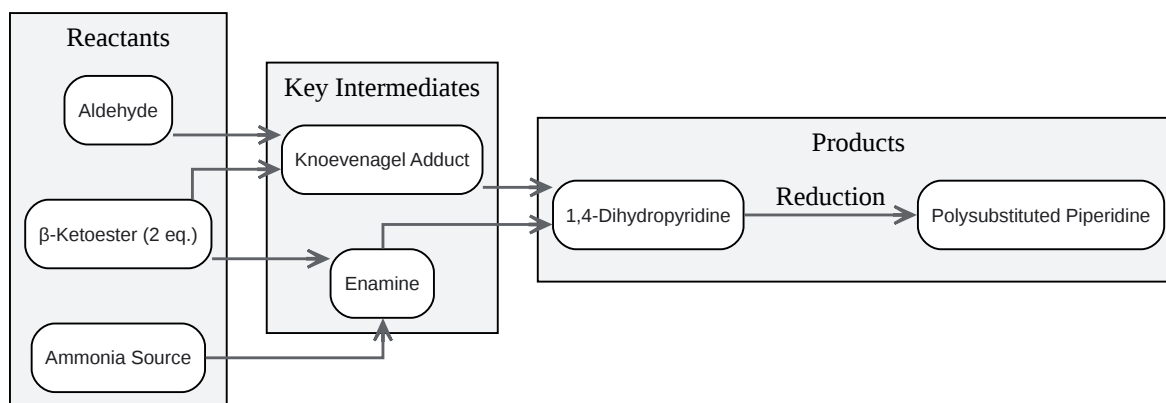

[Click to download full resolution via product page](#)

Caption: Workflow for Hantzsch synthesis and subsequent reduction.

The Petasis Borono-Mannich (PBM) Reaction

The Petasis reaction is a versatile three-component reaction of an amine, a carbonyl compound, and a vinyl- or aryl-boronic acid to produce substituted amines.^[9] When cyclic amines or precursors are used, this reaction provides a powerful entry to substituted piperidines.

Mechanistic Insights: The reaction is believed to proceed through the formation of an iminium ion from the amine and carbonyl component. The boronic acid then forms a tetracoordinate "ate" complex, which facilitates the transfer of the organic group from boron to the iminium carbon.^{[10][11]}

Experimental Protocol: Petasis Synthesis of a Substituted Piperidine

This protocol is adapted from literature procedures for the synthesis of α -amino acids, a common application of the Petasis reaction that can be extended to piperidine derivatives.^[12]

Materials:

- Piperidine derivative (amine component, 1.0 mmol)
- Glyoxylic acid (carbonyl component, 1.2 mmol)
- Aryl or vinyl boronic acid (1.2 mmol)
- Dichloromethane (DCM) or Toluene (solvent)

Procedure:

- To a solution of the piperidine derivative (1.0 mmol) and glyoxylic acid (1.2 mmol) in the chosen solvent, add the boronic acid (1.2 mmol).
- Stir the reaction mixture at room temperature or with gentle heating (e.g., 40-60°C) until the reaction is complete (monitored by LC-MS).
- Upon completion, dilute the reaction with an appropriate organic solvent and wash with saturated aqueous sodium bicarbonate.
- Separate the organic layer, dry over anhydrous sodium sulfate, and concentrate under reduced pressure.

- Purify the crude product by flash column chromatography.

Visualization: Petasis Borono-Mannich Reaction Mechanism

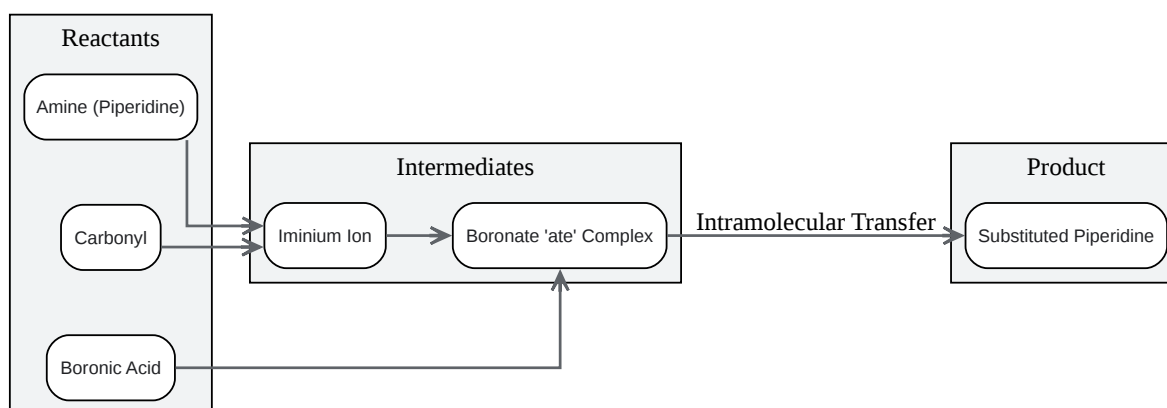

[Click to download full resolution via product page](#)

Caption: Key steps in the Petasis Borono-Mannich reaction.

The Ugi Four-Component Reaction (U-4CR)

The Ugi reaction is a powerful MCR that combines an aldehyde or ketone, an amine, a carboxylic acid, and an isocyanide to form a bis-amide.^[13] By using bifunctional starting materials, the Ugi reaction can be adapted for the synthesis of heterocyclic scaffolds, including piperidines.^{[11][14]}

Mechanistic Rationale: The reaction proceeds through the formation of an imine, which is then attacked by the isocyanide. The resulting nitrilium ion is trapped by the carboxylate, and a subsequent Mumm rearrangement yields the final product.^[15] The irreversibility of the Mumm rearrangement drives the reaction to completion.

Experimental Protocol: Ugi-based Synthesis of a Piperidine Derivative

This protocol outlines a general procedure for a solid-phase Ugi reaction to generate a library of N-substituted pyrrolidinone-tethered N-substituted piperidines.[11]

Materials:

- Resin-bound glutamic acid
- Ketone (e.g., Boc-piperidone, 2 equiv.)
- Isocyanide (2 equiv.)
- Acetonitrile/methanol (4:1)
- Trifluoroacetic acid (TFA)/DCM (for deprotection)
- Capping agents (sulfonyl chlorides, isocyanates, etc.)

Procedure:

- Swell the resin-bound glutamic acid in a solution of the ketone (2 equiv.) in acetonitrile/methanol (4:1) for 1 hour at 65°C.
- Add the isocyanide (2 equiv.) and continue heating until the reaction is complete.
- Wash the resin and deprotect the Boc group using 55% TFA in DCM.
- Treat the resin-bound piperidine with a variety of capping agents to generate a library of compounds.
- Cleave the final products from the resin and purify as necessary.

Visualization: Ugi Four-Component Reaction for Heterocycle Synthesis

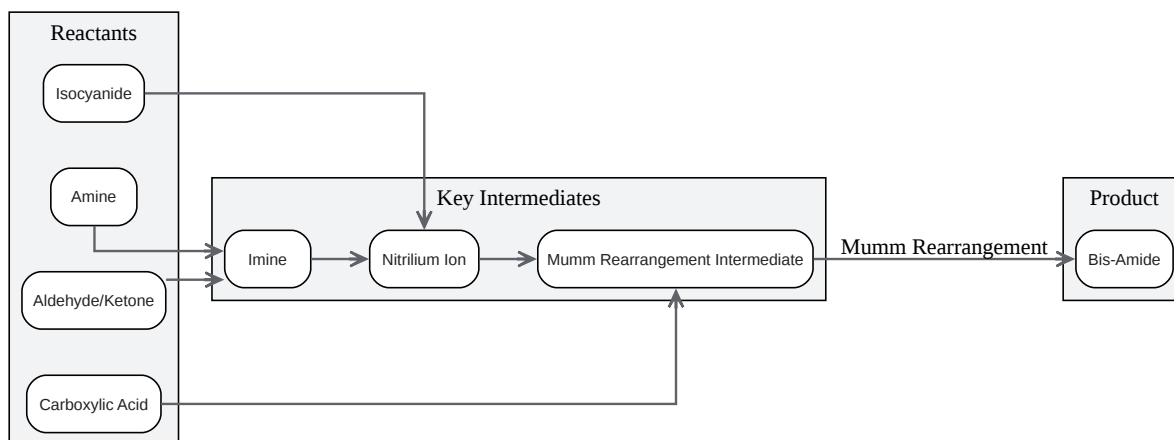

[Click to download full resolution via product page](#)

Caption: The convergent mechanism of the Ugi four-component reaction.

Domino and Cascade Reactions: Building Complexity in a Single Stroke

Domino or cascade reactions are processes involving two or more bond-forming transformations that take place under the same reaction conditions without the addition of further reagents or catalysts. These reactions are highly desirable for their efficiency in rapidly building molecular complexity.

Aza-Diels-Alder Reactions

The aza-Diels-Alder reaction, the hetero-Diels-Alder reaction of an imine with a diene, is a powerful method for the construction of tetrahydropyridines, which are immediate precursors to piperidines.^[16] One-pot versions often involve the in situ generation of the imine.

Mechanistic Considerations: The mechanism can be either concerted or stepwise, depending on the nature of the reactants and the catalyst used.^[17] Lewis acids or Brønsted acids are

commonly employed to activate the imine dienophile.

Visualization: One-Pot Aza-Diels-Alder Reaction

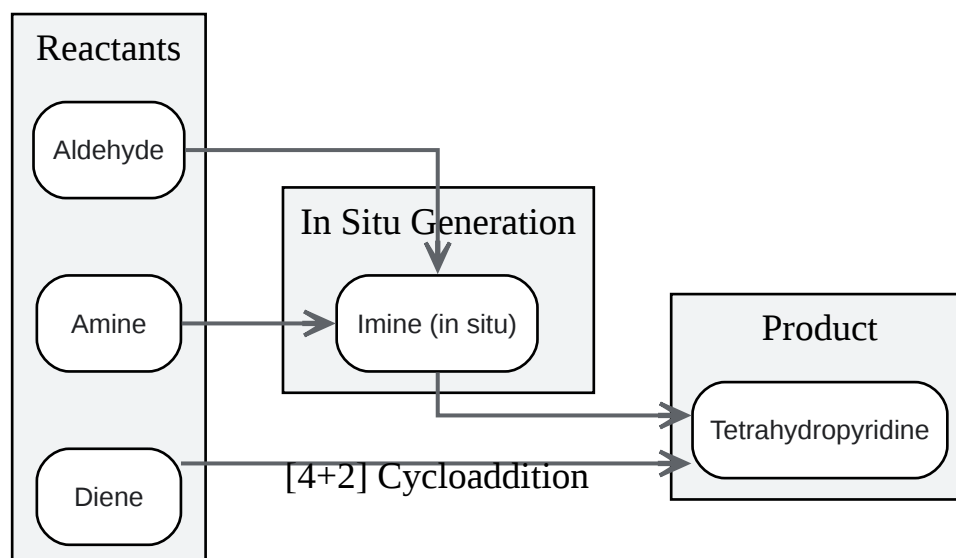

[Click to download full resolution via product page](#)

Caption: In situ imine formation followed by cycloaddition.

Michael Addition/Nitro-Mannich/Lactamization Cascade

This powerful cascade reaction allows for the synthesis of highly functionalized 2-piperidinones from simple starting materials in a single pot.[18]

Experimental Protocol: Four-Component Synthesis of a 2-Piperidinone

This protocol is based on a reported four-component reaction for the synthesis of polysubstituted 2-piperidinones.[18]

Materials:

- Substituted nitrostyrene (1.0 mmol)
- Aromatic aldehyde (1.0 mmol)

- Ammonium acetate (2.0 mmol)
- Dialkyl malonate (1.0 mmol)
- Ethanol (solvent)

Procedure:

- A mixture of the substituted nitrostyrene (1.0 mmol), aromatic aldehyde (1.0 mmol), ammonium acetate (2.0 mmol), and dialkyl malonate (1.0 mmol) in ethanol is stirred at reflux.
- The reaction progress is monitored by TLC.
- Upon completion, the reaction mixture is cooled, and the precipitated product is collected by filtration.
- The crude product can be further purified by recrystallization or column chromatography.

Data Presentation: Comparison of One-Pot Synthesis Methods

Method	Key Features	Advantages	Limitations
Hantzsch-type	Aldehyde, 2x β -ketoester, ammonia source	Well-established, high yields, access to dihydropyridines	Can require harsh conditions, subsequent reduction needed
Petasis (PBM)	Amine, carbonyl, boronic acid	Mild conditions, broad substrate scope, C-C bond formation	Boronic acids can be expensive, some are unstable
Ugi (U-4CR)	Aldehyde, amine, carboxylic acid, isocyanide	High atom economy, rapid, high diversity	Isocyanides can be toxic and have strong odors
Aza-Diels-Alder	Imine, diene	Direct access to tetrahydropyridines, good stereocontrol	Limited diene scope, can require catalysts
Domino/Cascade	Multiple bond formations in one pot	High complexity generation, elegant	Can be sensitive to reaction conditions, mechanism can be complex

Conclusion: The Future of Piperidine Synthesis

The development of one-pot methodologies for the synthesis of polysubstituted piperidines continues to be a vibrant area of research. These methods offer significant advantages in terms of efficiency, atom economy, and environmental impact over traditional multi-step syntheses. As our understanding of reaction mechanisms deepens and new catalytic systems are discovered, we can expect even more powerful and selective one-pot strategies to emerge, further empowering the synthesis of novel piperidine-based therapeutics.

References

- Ugi, I. (1959). The Ugi Reaction. *Angewandte Chemie*, 71(11), 386.
- Hantzsch, A. (1881). Condensation of Aldehyde-Ammonia with Acetoacetic Ether. *Berichte der deutschen chemischen Gesellschaft*, 14(2), 1637-1638.
- Petasis, N. A., & Akritopoulou, I. (1993). A New and Practical Synthesis of α -Amino Acids from Aldehydes and Ketones. *Tetrahedron Letters*, 34(4), 583-586.

- Alizadeh, A., & Faghani, Z. (2012). Synthesis of Polysubstituted 2-Piperidinones via a Michael Addition/Nitro-Mannich/Lactamization Cascade. *ACS Combinatorial Science*, 14(7), 419-422. [\[Link\]](#)
- Whiting, A., & Laudo, L. T. (2011). Mannich–Michael versus formal aza-Diels–Alder approaches to piperidine derivatives. *Organic & Biomolecular Chemistry*, 9(10), 3587-3597. [\[Link\]](#)
- Domling, A., & Ugi, I. (2000). Multicomponent Reactions with Isocyanides.
- El Kaim, L., Grimaud, L., & Oble, J. (2005). Phenol Ugi–Smiles Systems: Strategies for the Multicomponent N-Arylation of Primary Amines with Isocyanides, Aldehydes, and Phenols. *Angewandte Chemie International Edition*, 44(48), 7961-7964. [\[Link\]](#)
- Touré, B. B., & Hall, D. G. (2009). Natural Product Synthesis Using Multicomponent Reaction Strategies. *Chemical Reviews*, 109(9), 4439-4486.
- Song, Q., et al. (2022). One-Pot Route from Halogenated Amides to Piperidines and Pyrrolidines. *Molecules*, 27(15), 4698. [\[Link\]](#)
- Candeias, N. R., et al. (2012). Insights on the Petasis Borono–Mannich multicomponent reaction mechanism. *Chemical Communications*, 48(85), 10541-10543. [\[Link\]](#)
- Kazmaier, U., & Ackermann, S. (2005). A straightforward approach towards thiazoles and endothiopeptides via Ugi reaction. *Organic & Biomolecular Chemistry*, 3(17), 3184-3187.
- Rocha, R. O., et al. (2020). Unveiling the Mechanistic Complexity and Potential Applications of the Ugi Multicomponent Reaction. *Amerigo Scientific*. [\[Link\]](#)
- Bon, R. S., & Waldmann, H. (2010). Piperidine-based drug discovery. *Chemical Reviews*, 110(11), 6531-6575.
- Song, Q., et al. (2022). One-Pot Route from Halogenated Amides to Piperidines and Pyrrolidines. *Molecules*, 27(15), 4698. [\[Link\]](#)
- Ferreira, I. C. F. R., et al. (2023). The Asymmetric Petasis Borono-Mannich Reaction: Insights on the Last 15 Years. *Catalysts*, 13(6), 1022. [\[Link\]](#)

- Chen, Y., et al. (2016). One-pot, highly efficient, asymmetric synthesis of ring-fused piperidine derivatives bearing N,O- or N,N-acetal moieties. *Organic & Biomolecular Chemistry*, 14(3), 856-860. [\[Link\]](#)
- Laudo, L. T., & Whiting, A. (2011). Mannich–Michael versus formal aza-Diels–Alder approaches to piperidine derivatives. *Organic & Biomolecular Chemistry*, 9(10), 3587-3597. [\[Link\]](#)
- Vitaku, E., Smith, D. T., & Njardarson, J. T. (2014). Analysis of the structural diversity, substitution patterns, and frequency of nitrogen heterocycles among U.S. FDA approved pharmaceuticals. *Journal of Medicinal Chemistry*, 57(24), 10257-10274.
- Miller, A. K., & Woerpel, K. A. (2009). A Catalytic Asymmetric Synthesis of Polysubstituted Piperidines Using a Rhodium (I) Catalyzed [2+2+2] Cycloaddition Employing a Cleavable Tether. *Journal of the American Chemical Society*, 131(43), 15612-15613. [\[Link\]](#)
- Goswami, S. V., Thorat, P. B., & Bhusare, S. R. (2012). An efficient one-pot multi-component synthesis of highly functionalized piperidines. *Heterocyclic Communications*, 18(5-6), 245-248. [\[Link\]](#)
- Song, Q., et al. (2022). One-Pot Route from Halogenated Amides to Piperidines and Pyrrolidines. *Molecules*, 27(15), 4698. [\[Link\]](#)
- Song, Q., et al. (2022). One-Pot Route from Halogenated Amides to Piperidines and Pyrrolidines. *Molecules*, 27(15), 4698. [\[Link\]](#)
- Bapurao, B. S., et al. (2013). Synthesis of functionalized piperidines by one-pot multicomponent reaction using nano-crystalline solid acid catalysts. *Journal of the Serbian Chemical Society*, 78(10), 1461-1471.
- Petasis, N. A. (2024). Petasis reaction. Wikipedia. [\[Link\]](#)
- Green approach for synthesis of bioactive Hantzsch 1,4-dihydropyridine derivatives based on thiophene moiety via multicomponent reaction. Wikimedia Commons. [\[Link\]](#)
- Zhao, W., & Chen, F.-E. (2012). One-pot Synthesis and its Practical Application in Pharmaceutical Industry. *Current Organic Synthesis*, 9(6), 753-775.

- Laudo, L. T., & Whiting, A. (2011). Review: Mannich–Michael vs. aza-Diels–Alder approaches to piperidine derivatives. Royal Society of Chemistry. [\[Link\]](#)
- Romanov, A. R., et al. (2023). Piperidine Derivatives: Recent Advances in Synthesis and Pharmacological Applications. *Molecules*, 28(3), 1369. [\[Link\]](#)
- Petasis Reaction. Organic Chemistry Portal. [\[Link\]](#)
- Synthesis of the 1,4-disubstituted piperidine library via Ugi four-component reaction. ResearchGate. [\[Link\]](#)
- Ugi reaction. Wikipedia. [\[Link\]](#)
- Petasis, N. A. (2024). Petasis reaction. Wikipedia. [\[Link\]](#)
- Rice University. (2024). New molecule-creation method a 'powerful tool' to accelerate drug synthesis and discovery. ScienceDaily. [\[Link\]](#)
- Clarke, P. A., et al. (2007). Pot, atom and step economic (PASE) synthesis of highly functionalized piperidines: a five-component condensation. *Organic & Biomolecular Chemistry*, 5(11), 1731-1733.
- Green approach for synthesis of bioactive Hantzsch 1,4-dihydropyridine derivatives based on thiophene moiety via multicomponent reaction. Wikimedia Commons. [\[Link\]](#)
- Buffat, M. G. (2004). Recent advances in the synthesis of piperidones and piperidines. *Tetrahedron*, 60(8), 1701-1729.
- Van der Westhuizen, J. H., et al. (2020). One-pot multicomponent green Hantzsch synthesis of 1,2-dihydropyridine derivatives with antiproliferative activity. *Beilstein Journal of Organic Chemistry*, 16, 2898-2907. [\[Link\]](#)
- The endo-aza-Michael addition in the synthesis of piperidines and pyrrolidines. DR-NTU. [\[Link\]](#)
- Zare, A., et al. (2012). ONE-POT SYNTHESIS OF HANTZSCH ESTERS AND POLYHYDROQUINOLINE DERIVATIVES CATALYZED BY γ -Al₂O₃-NANOPARTICLES

UNDER SOLVENT-FREE CONDITIONS. Journal of the Chilean Chemical Society, 57(4), 1381-1384.

Need Custom Synthesis?

BenchChem offers custom synthesis for rare earth carbides and specific isotopic labeling.

Email: info@benchchem.com or [Request Quote Online](#).

Sources

- [1. mdpi.com](https://www.mdpi.com) [[mdpi.com](https://www.mdpi.com)]
- [2. researchgate.net](https://www.researchgate.net) [[researchgate.net](https://www.researchgate.net)]
- [3. news-medical.net](https://www.news-medical.net) [[news-medical.net](https://www.news-medical.net)]
- [4. One-pot synthesis of 3-azido- and 3-aminopiperidines by intramolecular cyclization of unsaturated amines - PubMed](#) [pubmed.ncbi.nlm.nih.gov]
- [5. pdf.benchchem.com](https://pdf.benchchem.com) [pdf.benchchem.com]
- [6. pubs.acs.org](https://pubs.acs.org) [pubs.acs.org]
- [7. revroum.lew.ro](https://www.revroum.lew.ro) [[revroum.lew.ro](https://www.revroum.lew.ro)]
- [8. upload.wikimedia.org](https://upload.wikimedia.org) [upload.wikimedia.org]
- [9. Petasis reaction - Wikipedia](https://en.wikipedia.org) [en.wikipedia.org]
- [10. Petasis Reaction](https://www.organic-chemistry.org) [[organic-chemistry.org](https://www.organic-chemistry.org)]
- [11. Insights on the Petasis Borono–Mannich multicomponent reaction mechanism - RSC Advances \(RSC Publishing\)](#) [pubs.rsc.org]
- [12. fileserv-az.core.ac.uk](https://fileserv-az.core.ac.uk) [fileserv-az.core.ac.uk]
- [13. Piperidine synthesis](https://www.organic-chemistry.org) [[organic-chemistry.org](https://www.organic-chemistry.org)]
- [14. alfa-chemistry.com](https://www.alfa-chemistry.com) [[alfa-chemistry.com](https://www.alfa-chemistry.com)]
- [15. Ugi Reaction](https://www.organic-chemistry.org) [[organic-chemistry.org](https://www.organic-chemistry.org)]
- [16. researchgate.net](https://www.researchgate.net) [[researchgate.net](https://www.researchgate.net)]
- [17. Mannich–Michael versus formal aza-Diels–Alder approaches to piperidine derivatives - Organic & Biomolecular Chemistry \(RSC Publishing\)](#) [pubs.rsc.org]
- [18. researchgate.net](https://www.researchgate.net) [[researchgate.net](https://www.researchgate.net)]

- To cite this document: BenchChem. [One-Pot Synthesis of Polysubstituted Piperidines: A Senior Application Scientist's Guide]. BenchChem, [2026]. [Online PDF]. Available at: [<https://www.benchchem.com/product/b14785948/docs#one-pot-synthesis-of-polysubstituted-piperidines-a-senior-application-scientist-s-guide>]

Disclaimer & Data Validity:

The information provided in this document is for Research Use Only (RUO) and is strictly not intended for diagnostic or therapeutic procedures. While BenchChem strives to provide accurate protocols, we make no warranties, express or implied, regarding the fitness of this product for every specific experimental setup.

Technical Support: The protocols provided are for reference purposes. Unsure if this reagent suits your experiment?

Need Industrial/Bulk Grade? [Request Custom Synthesis Quote](#)

BenchChem

Our mission is to be the trusted global source of essential and advanced chemicals, empowering scientists and researchers to drive progress in science and industry.

Contact

Address: 3281 E Guasti Rd
Ontario, CA 91761, United States
Phone: (601) 213-4426
Email: info@benchchem.com

[Contact our Ph.D. Support Team for a compatibility check](#)