

# Understanding the Biological Activity of PCSK9 Small Molecule Inhibitors: A Technical Guide

**Author:** BenchChem Technical Support Team. **Date:** April 2026

## Compound of Interest

Compound Name: PCSK9-IN-29

Cat. No.: B14783546

[Get Quote](#)

For Researchers, Scientists, and Drug Development Professionals

## Abstract

Proprotein convertase subtilisin/kexin type 9 (PCSK9) is a key regulator of low-density lipoprotein (LDL) cholesterol metabolism.<sup>[1][2][3][4][5]</sup> By promoting the degradation of the LDL receptor (LDLR), PCSK9 reduces the clearance of LDL cholesterol from the bloodstream, leading to elevated plasma LDL-C levels, a major risk factor for cardiovascular disease.<sup>[4][5][6][7]</sup> Inhibition of the PCSK9-LDLR interaction has emerged as a validated therapeutic strategy for lowering LDL-C.<sup>[6][8][9][10]</sup> While monoclonal antibodies have been successful in targeting circulating PCSK9, there is significant interest in the development of orally bioavailable small molecule inhibitors. This guide provides an in-depth overview of the biological activity of a representative small molecule PCSK9 inhibitor, herein referred to as PCSK9-IN-XX, and details the experimental protocols used for its characterization.

## Mechanism of Action of PCSK9

PCSK9 is a serine protease that is primarily synthesized and secreted by the liver.<sup>[6][7]</sup> Circulating PCSK9 binds to the epidermal growth factor-like repeat A (EGF-A) domain of the LDLR on the surface of hepatocytes.<sup>[2][11]</sup> This binding prevents the recycling of the LDLR

back to the cell surface after endocytosis of the LDLR-LDL complex.[6][8] Instead, the entire complex is targeted for degradation in the lysosome.[2][6][8] This reduction in the number of available LDLRs on the cell surface leads to decreased clearance of LDL-C from the circulation and consequently, higher plasma LDL-C levels.[4][5][6]

## Biological Activity of PCSK9-IN-XX

PCSK9-IN-XX is a hypothetical small molecule inhibitor designed to disrupt the interaction between PCSK9 and the LDLR. Its biological activity is characterized by its ability to bind to PCSK9, inhibit the PCSK9-LDLR interaction, and ultimately increase the uptake of LDL-C by liver cells.

## Data Presentation

The following tables summarize the quantitative data for the biological activity of PCSK9-IN-XX.

Table 1: In Vitro Biochemical Activity

Assay Type	Parameter	PCSK9-IN-XX
HTRF Binding Assay	IC50 (nM)	50
Surface Plasmon Resonance (SPR)	KD (nM)	100

Table 2: Cell-Based Activity

Assay Type	Cell Line	Parameter	PCSK9-IN-XX
LDL-C Uptake Assay	HepG2	EC50 (nM)	200
Max LDL-C Uptake (%)	85		

## Experimental Protocols

## Homogeneous Time-Resolved Fluorescence (HTRF) Binding Assay

This assay is used to measure the ability of a compound to inhibit the binding of PCSK9 to the LDLR's EGF-A domain.

Methodology:

- Recombinant human PCSK9 and the LDLR EGF-A domain are used.
- PCSK9 is labeled with a donor fluorophore (e.g., Europium cryptate), and the EGF-A domain is labeled with an acceptor fluorophore (e.g., d2).[12]
- In the absence of an inhibitor, the binding of PCSK9 to the EGF-A domain brings the donor and acceptor fluorophores into close proximity, resulting in a high FRET signal.
- PCSK9-IN-XX is serially diluted and incubated with PCSK9 and the EGF-A domain.
- The reaction is incubated for a specified period (e.g., 2 hours) at room temperature.[12]
- The HTRF signal is read on a compatible plate reader.
- The IC50 value, the concentration of inhibitor required to reduce the FRET signal by 50%, is calculated from the dose-response curve.

## Surface Plasmon Resonance (SPR)

SPR is a label-free technique used to measure the binding kinetics and affinity (KD) between PCSK9 and the inhibitor.

Methodology:

- Recombinant human PCSK9 is immobilized on a sensor chip surface.
- A solution containing PCSK9-IN-XX at various concentrations is flowed over the sensor chip surface.

- The binding of the inhibitor to the immobilized PCSK9 causes a change in the refractive index at the surface, which is detected by the SPR instrument.
- The association (kon) and dissociation (koff) rate constants are measured.
- The equilibrium dissociation constant (KD) is calculated as the ratio of koff/kon.

## Cell-Based LDL-C Uptake Assay

This assay measures the functional consequence of PCSK9 inhibition, which is the increased uptake of LDL-C by liver cells.[13][14]

Methodology:

- Human hepatoma cells (e.g., HepG2) are cultured in 96-well plates.[13]
- The cells are treated with various concentrations of PCSK9-IN-XX in the presence of a fixed concentration of recombinant human PCSK9.[13]
- After an incubation period, fluorescently labeled LDL (e.g., Bodipy-FL-LDL) is added to the cells.[13]
- The cells are incubated for a further period (e.g., 4 hours) to allow for the uptake of the labeled LDL.[13]
- The cells are washed to remove any unbound labeled LDL.
- The fluorescence intensity within the cells is measured using a fluorescence plate reader or a high-content imaging system.[13]
- The EC50 value, the concentration of the inhibitor that results in a 50% increase in LDL uptake, and the maximum percentage of LDL uptake are determined from the dose-response curve.

## Signaling Pathways and Experimental Workflows

### Signaling Pathway

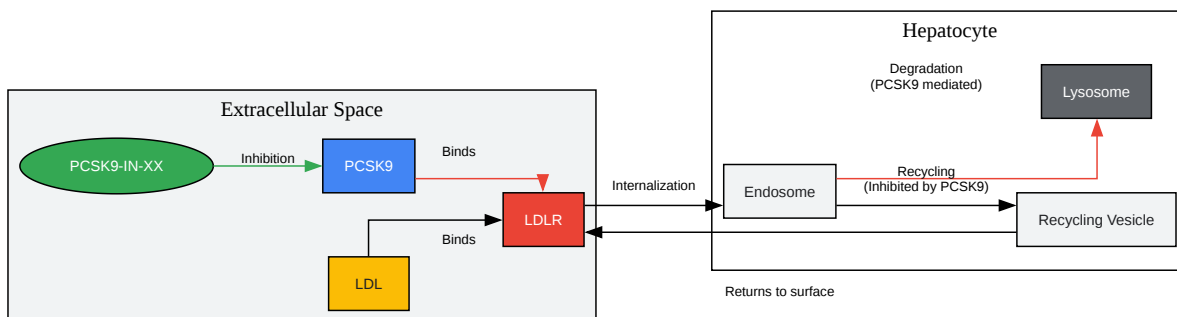

[Click to download full resolution via product page](#)

Caption: PCSK9 signaling pathway and the inhibitory action of PCSK9-IN-XX.

## Experimental Workflow: HTRF Assay

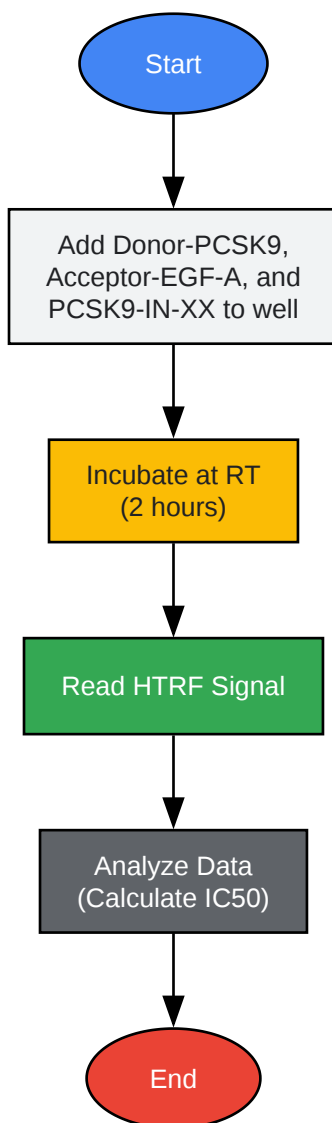

[Click to download full resolution via product page](#)

Caption: Workflow for the Homogeneous Time-Resolved Fluorescence (HTRF) assay.

## Experimental Workflow: Cell-Based LDL-C Uptake Assay

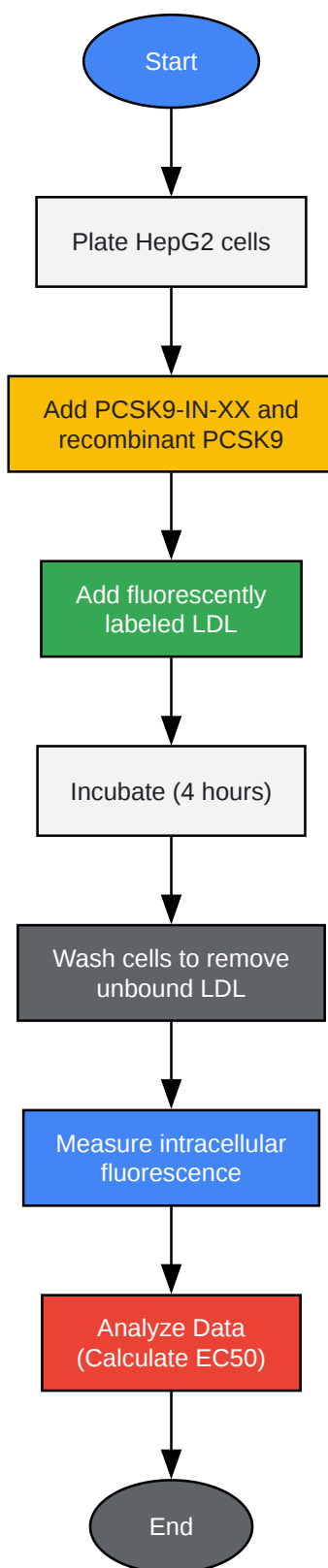

[Click to download full resolution via product page](#)

Caption: Workflow for the cell-based LDL-C uptake assay.

### Need Custom Synthesis?

BenchChem offers custom synthesis for rare earth carbides and specific isotopic labeling.

Email: [info@benchchem.com](mailto:info@benchchem.com) or [Request Quote Online](#).

## References

- [1. researchgate.net \[researchgate.net\]](https://www.researchgate.net)
- [2. PCSK9 signaling pathways and their potential importance in clinical practice - PMC \[pmc.ncbi.nlm.nih.gov\]](https://pubmed.ncbi.nlm.nih.gov/23111111/)
- [3. PCSK9 signaling pathways and their potential importance in clinical practice - PubMed \[pubmed.ncbi.nlm.nih.gov\]](https://pubmed.ncbi.nlm.nih.gov/23111111/)
- [4. my.clevelandclinic.org \[my.clevelandclinic.org\]](https://my.clevelandclinic.org)
- [5. PCSK9 Inhibitors - StatPearls - NCBI Bookshelf \[ncbi.nlm.nih.gov\]](https://pubmed.ncbi.nlm.nih.gov/23111111/)
- [6. bpsbioscience.com \[bpsbioscience.com\]](https://bpsbioscience.com)
- [7. mdpi.com \[mdpi.com\]](https://www.mdpi.com)
- [8. heartcare.sydney \[heartcare.sydney\]](https://www.heartcare.sydney)
- [9. PCSK9 Inhibitors: The Evolving Future - PMC \[pmc.ncbi.nlm.nih.gov\]](https://pubmed.ncbi.nlm.nih.gov/23111111/)
- [10. ahajournals.org \[ahajournals.org\]](https://www.ahajournals.org)
- [11. Frontiers | Regulation of PCSK9 Expression and Function: Mechanisms and Therapeutic Implications \[frontiersin.org\]](https://www.frontiersin.org)
- [12. revvity.com \[revvity.com\]](https://www.revvity.com)
- [13. walshmedicalmedia.com \[walshmedicalmedia.com\]](https://www.walshmedicalmedia.com)
- [14. researchgate.net \[researchgate.net\]](https://www.researchgate.net)
- To cite this document: BenchChem. [Understanding the Biological Activity of PCSK9 Small Molecule Inhibitors: A Technical Guide]. BenchChem, [2026]. [Online PDF]. Available at: [\[https://www.benchchem.com/product/b14783546/docs#understanding-the-biological-activity-of-pcsk9-small-molecule-inhibitors-a-technical-guide\]](https://www.benchchem.com/product/b14783546/docs#understanding-the-biological-activity-of-pcsk9-small-molecule-inhibitors-a-technical-guide)

---

### Disclaimer & Data Validity:

The information provided in this document is for Research Use Only (RUO) and is strictly not intended for diagnostic or therapeutic procedures. While BenchChem strives to provide accurate protocols, we make no warranties, express or implied, regarding the fitness of this product for every specific experimental setup.

**Technical Support:** The protocols provided are for reference purposes. Unsure if this reagent suits your experiment?

**Need Industrial/Bulk Grade?** [Request Custom Synthesis Quote](#)

## BenchChem

Our mission is to be the trusted global source of essential and advanced chemicals, empowering scientists and researchers to drive progress in science and industry.

### Contact

Address: 3281 E Guasti Rd  
Ontario, CA 91761, United States  
Phone: (601) 213-4426  
Email: [info@benchchem.com](mailto:info@benchchem.com)

[Contact our Ph.D. Support Team for a compatibility check](#)