

# "Methodology for evaluating PCSK9-IN-29 in hypercholesterolemia models"

**Author:** BenchChem Technical Support Team. **Date:** April 2026

## Compound of Interest

Compound Name: PCSK9-IN-29

Cat. No.: B14783546

[Get Quote](#)

## Methodology for Evaluating PCSK9-IN-29 in Hypercholesterolemia Models

### Application Notes and Protocols for Researchers

Audience: Researchers, scientists, and drug development professionals.

Introduction: Proprotein Convertase Subtilisin/Kexin type 9 (PCSK9) is a key regulator of cholesterol homeostasis.[1][2] It functions by binding to the Low-Density Lipoprotein Receptor (LDLR) on the surface of hepatocytes, targeting it for lysosomal degradation.[3][4][5] This reduction in LDLR density leads to decreased clearance of LDL cholesterol (LDL-C) from the circulation, resulting in elevated plasma LDL-C levels.[2][3] Inhibition of PCSK9 has emerged as a promising therapeutic strategy for managing hypercholesterolemia.[3][6] PCSK9 inhibitors, such as monoclonal antibodies, prevent the PCSK9-LDLR interaction, leading to increased LDLR recycling and enhanced LDL-C clearance.[5][7] This document outlines a comprehensive methodology for the preclinical evaluation of a novel small molecule inhibitor, **PCSK9-IN-29**, in various hypercholesterolemia models.

## In Vitro Evaluation of PCSK9-IN-29

## Biochemical Assays

Objective: To determine the direct inhibitory effect of **PCSK9-IN-29** on the PCSK9-LDLR interaction and on PCSK9 autocleavage.

Protocols:

- PCSK9-LDLR Binding Assay (ELISA-based):
  - Coat a 96-well plate with recombinant human LDLR-EGF-A domain.
  - Block non-specific binding sites.
  - Pre-incubate various concentrations of **PCSK9-IN-29** with recombinant human PCSK9.
  - Add the PCSK9/**PCSK9-IN-29** mixture to the LDLR-coated wells.
  - Wash the wells to remove unbound PCSK9.
  - Detect bound PCSK9 using a specific primary antibody followed by a horseradish peroxidase (HRP)-conjugated secondary antibody.
  - Add a colorimetric substrate and measure the absorbance to quantify the amount of bound PCSK9.
  - Calculate the IC<sub>50</sub> value of **PCSK9-IN-29**.
- PCSK9 Autoprocessing Assay:
  - Express and purify a truncated pro-PCSK9 construct.[8]
  - Incubate the pro-PCSK9 with varying concentrations of **PCSK9-IN-29**.
  - Monitor the autocatalytic cleavage of pro-PCSK9 into its mature form over time using automated Western analysis or liquid chromatography-mass spectrometry.[8]
  - Determine the effect of **PCSK9-IN-29** on the rate of autoprocessing.[8]

## Cell-Based Assays

Objective: To assess the functional activity of **PCSK9-IN-29** in a cellular context.

Protocols:

- LDL Uptake Assay in HepG2 Cells:
  - Culture HepG2 human liver cells in appropriate media.[9]
  - Treat the cells with varying concentrations of **PCSK9-IN-29** in the presence of recombinant PCSK9.
  - Incubate the treated cells with fluorescently labeled LDL (e.g., DiI-LDL).
  - Measure the cellular uptake of DiI-LDL using flow cytometry or fluorescence microscopy.
  - An increase in DiI-LDL uptake would indicate that **PCSK9-IN-29** is preventing PCSK9-mediated LDLR degradation.[10]
- LDLR Protein Expression by Western Blot:
  - Culture HepG2 cells and treat with **PCSK9-IN-29** in the presence of recombinant PCSK9.
  - Lyse the cells and quantify total protein concentration.
  - Separate proteins by SDS-PAGE and transfer to a membrane.
  - Probe the membrane with primary antibodies against LDLR and a loading control (e.g., GAPDH).
  - Use a labeled secondary antibody for detection and quantify band intensities.
  - An increase in LDLR protein levels would confirm the inhibitory effect of **PCSK9-IN-29**.

## In Vivo Evaluation of **PCSK9-IN-29** Animal Models of Hypercholesterolemia

Objective: To evaluate the efficacy and safety of **PCSK9-IN-29** in relevant animal models.

Model Selection:

- Wild-type mice on a high-fat/high-cholesterol diet: To assess the effect of **PCSK9-IN-29** in a diet-induced hypercholesterolemia model.
- LDLR-deficient (Ldlr<sup>-/-</sup>) mice: To investigate the LDLR-dependent mechanism of action of **PCSK9-IN-29**.
- Humanized PCSK9 transgenic mice: These models express human PCSK9 and are useful for testing the efficacy of inhibitors targeting the human protein.

## Experimental Protocols

- Pharmacokinetic (PK) Study:
  - Administer a single dose of **PCSK9-IN-29** to mice via the intended clinical route (e.g., oral gavage, subcutaneous injection).
  - Collect blood samples at various time points.
  - Measure the concentration of **PCSK9-IN-29** in plasma using a validated analytical method (e.g., LC-MS/MS).
  - Determine key PK parameters such as C<sub>max</sub>, T<sub>max</sub>, AUC, and half-life.
- Efficacy Study:
  - Acclimatize animals and induce hypercholesterolemia (if required by the model).
  - Divide animals into vehicle control and **PCSK9-IN-29** treatment groups (multiple dose levels).
  - Administer **PCSK9-IN-29** daily or as determined by the PK study for a predefined period (e.g., 2-4 weeks).
  - Monitor body weight and food consumption throughout the study.

- Collect blood samples at baseline and at the end of the treatment period for lipid analysis.
- At the end of the study, euthanize the animals and collect liver tissue for protein and gene expression analysis.

## Endpoint Analysis

- **Lipid Profile:** Measure plasma levels of total cholesterol, LDL-C, HDL-C, and triglycerides using standard enzymatic assays.
- **PCSK9 Levels:** Quantify plasma PCSK9 concentrations using a species-specific ELISA kit. [\[11\]](#)[\[12\]](#)
- **Liver LDLR Expression:** Analyze liver tissue for LDLR protein levels by Western blot and mRNA levels by qRT-PCR.
- **Safety and Tolerability:** Monitor for any adverse effects, and at necropsy, perform a gross examination of major organs. Histopathological analysis of the liver and other key organs should be conducted.

## Data Presentation

Table 1: In Vitro Activity of **PCSK9-IN-29**

Assay	Endpoint	PCSK9-IN-29	Positive Control (e.g., Alirocumab)
PCSK9-LDLR Binding	IC50 (nM)		
PCSK9 Autoprocessing	% Inhibition at 10 $\mu$ M		
LDL Uptake (HepG2)	EC50 (nM)		
LDLR Protein Expression	Fold Increase at 10 $\mu$ M		

Table 2: In Vivo Efficacy of **PCSK9-IN-29** in a Mouse Model of Hypercholesterolemia

Treatment Group	Dose (mg/kg)	Change in LDL-C (%)	Change in Total Cholesterol (%)	Change in Plasma PCSK9 (%)	Change in Liver LDLR Protein (fold)
Vehicle Control	-				
PCSK9-IN-29	Low Dose				
PCSK9-IN-29	Mid Dose				
PCSK9-IN-29	High Dose				
Positive Control	-				

## Visualizations

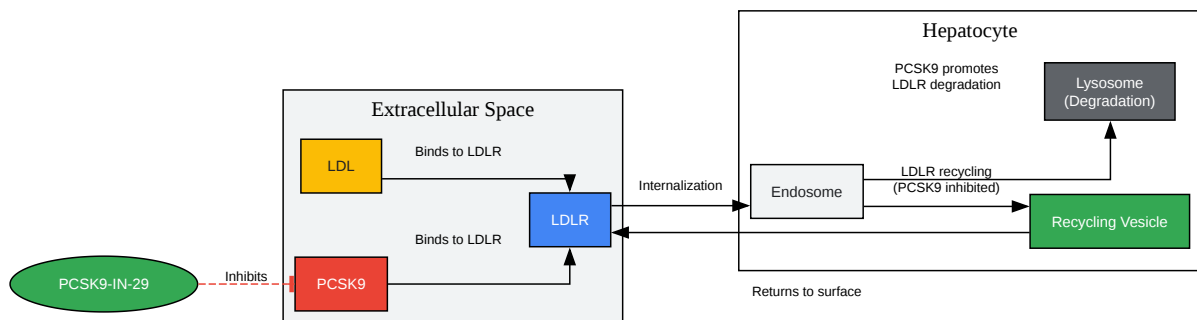

[Click to download full resolution via product page](#)

Caption: PCSK9 Signaling Pathway and Point of Inhibition.

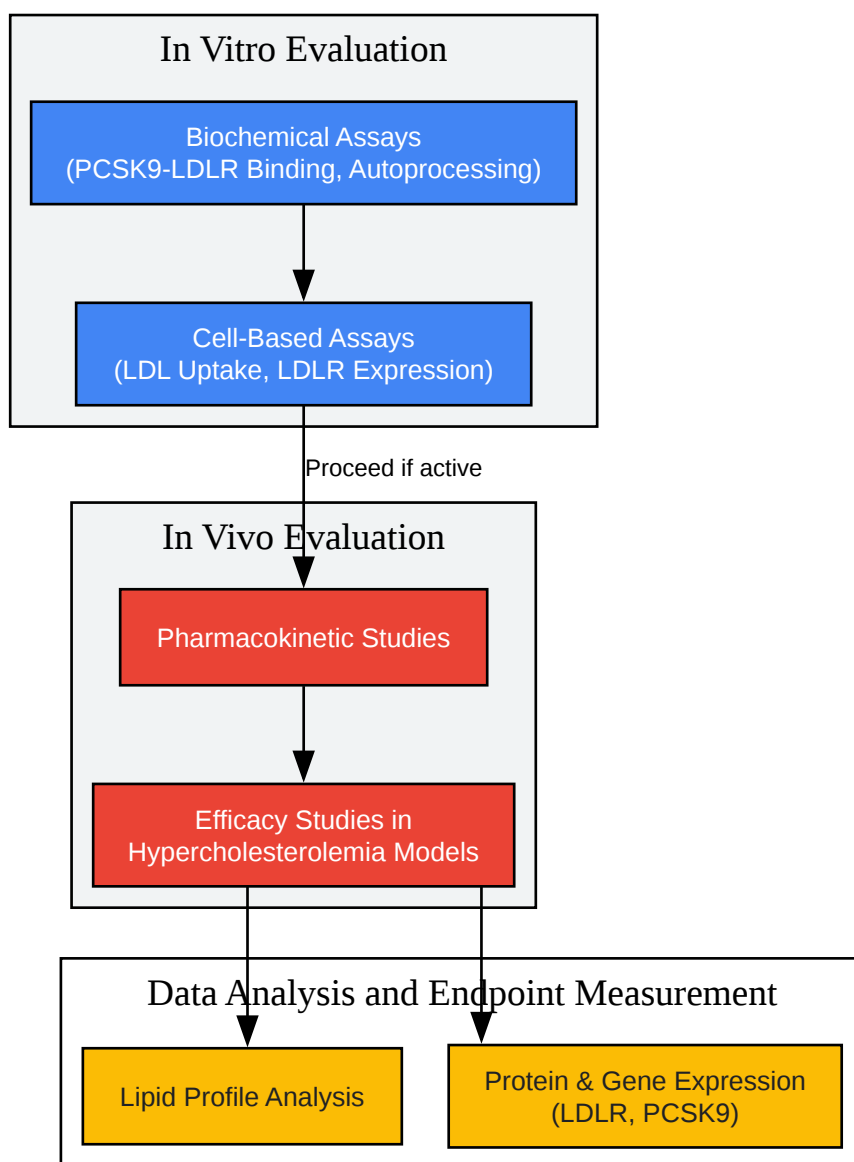

[Click to download full resolution via product page](#)

Caption: Experimental Workflow for Evaluating **PCSK9-IN-29**.

### Need Custom Synthesis?

BenchChem offers custom synthesis for rare earth carbides and specific isotopic labeling.

Email: [info@benchchem.com](mailto:info@benchchem.com) or [Request Quote Online](#).

## References

- [1. my.clevelandclinic.org \[my.clevelandclinic.org\]](https://my.clevelandclinic.org)
- [2. PCSK9 Inhibitors - StatPearls - NCBI Bookshelf \[ncbi.nlm.nih.gov\]](https://pubmed.ncbi.nlm.nih.gov/)
- [3. bpsbioscience.com \[bpsbioscience.com\]](https://bpsbioscience.com)
- [4. Frontiers | Regulation of PCSK9 Expression and Function: Mechanisms and Therapeutic Implications \[frontiersin.org\]](https://frontiersin.org)
- [5. heartcare.sydney \[heartcare.sydney\]](https://heartcare.sydney)
- [6. PCSK9 inhibition: A game changer in cholesterol management - Mayo Clinic \[mayoclinic.org\]](https://mayoclinic.org)
- [7. m.youtube.com \[m.youtube.com\]](https://m.youtube.com)
- [8. In Vitro Assays for the Discovery of PCSK9 Autoprocessing Inhibitors - PubMed \[pubmed.ncbi.nlm.nih.gov\]](https://pubmed.ncbi.nlm.nih.gov/)
- [9. researchgate.net \[researchgate.net\]](https://researchgate.net)
- [10. mdpi.com \[mdpi.com\]](https://mdpi.com)
- [11. PCSK9 ELISA Kits, PCSK9-LDLR, PCSK9-cIAP1 in vitro Binding Assay Kits | MBL Life Science -GLOBAL- \[mblbio.com\]](https://mblbio.com)
- [12. Establishment of an in vitro safety assessment model for lipid-lowering drugs using same-origin human pluripotent stem cell-derived cardiomyocytes and endothelial cells - PMC \[pmc.ncbi.nlm.nih.gov\]](https://pmc.ncbi.nlm.nih.gov/)
- To cite this document: BenchChem. ["Methodology for evaluating PCSK9-IN-29 in hypercholesterolemia models"]. BenchChem, [2026]. [Online PDF]. Available at: [\[https://www.benchchem.com/product/b14783546/docs#methodology-for-evaluating-pcsk9-in-29-in-hypercholesterolemia-models\]](https://www.benchchem.com/product/b14783546/docs#methodology-for-evaluating-pcsk9-in-29-in-hypercholesterolemia-models)

---

**Disclaimer & Data Validity:**

The information provided in this document is for Research Use Only (RUO) and is strictly not intended for diagnostic or therapeutic procedures. While BenchChem strives to provide accurate protocols, we make no warranties, express or implied, regarding the fitness of this product for every specific experimental setup.

**Technical Support:** The protocols provided are for reference purposes. Unsure if this reagent suits your experiment?

**Need Industrial/Bulk Grade?** [Request Custom Synthesis Quote](#)

# BenchChem

Our mission is to be the trusted global source of essential and advanced chemicals, empowering scientists and researchers to drive progress in science and industry.

## Contact

Address: 3281 E Guasti Rd  
Ontario, CA 91761, United States  
Phone: (601) 213-4426  
Email: [info@benchchem.com](mailto:info@benchchem.com)

[Contact our Ph.D. Support Team for a compatibility check](#)