

Scalable Synthesis of gem-Difluoro Piperidine Intermediates: Application Notes & Protocols

Author: BenchChem Technical Support Team. **Date:** April 2026

Compound of Interest

Compound Name: 3,3-Difluoro-5,5-dimethylpiperidin-4-ol
Cat. No.: B14779283

[Get Quote](#)

Executive Summary

The incorporation of gem-difluoromethylene ($-\text{CF}_2-$) groups into saturated nitrogen heterocycles is a privileged tactic in modern drug discovery. In piperidine scaffolds, the gem-difluoro moiety acts as an isosteric replacement for a ketone or ether, modulating the basicity (pK_a) of the distal amine, enhancing metabolic stability against cytochrome P450 oxidation, and increasing lipophilicity without imposing a significant steric penalty.

However, the scalable synthesis of these intermediates—most commonly achieved via the deoxofluorination of piperidone precursors like N-Boc-4-piperidone—presents formidable challenges. Traditional batch fluorination using Diethylaminosulfur trifluoride (DAST) or Deoxo-Fluor is plagued by severe safety risks (thermal runaway) and poor chemoselectivity (elimination byproducts). This application note details two field-proven, scalable methodologies designed to overcome these bottlenecks: a highly controlled batch protocol using the crystalline reagent XtalFluor-E, and a high-throughput continuous flow protocol utilizing DAST.

Mechanistic Rationale & Scalability Bottlenecks

The deoxofluorination of a ketone proceeds via the nucleophilic attack of the carbonyl oxygen onto the sulfur center of the fluorinating agent, forming an activated aminosulfur ether intermediate. Subsequent cleavage generates a transient carbocation (or tightly bound ion pair), which undergoes nucleophilic attack by fluoride to yield the gem-difluoro product.

The Causality of Failure at Scale

At the multigram or kilogram scale, the reaction is hindered by two primary failure modes:

- **The Elimination Pathway:** The transient carbocation is highly susceptible to E1-type elimination, yielding unwanted tetrahydropyridine (monofluoroalkene) byproducts. This pathway is exponentially accelerated by poor heat dissipation in large batch reactors.
- **Reagent Instability:** Liquid reagents like DAST decompose violently at temperatures above 50 °C. In batch vessels, localized exothermic "hot spots" can trigger catastrophic thermal runaway[1].

Engineered Solutions

- **Batch Optimization (XtalFluor-E):** XtalFluor-E is a crystalline dialkylaminodifluorosulfonium salt. It is thermally stable up to 80 °C and, crucially, does not generate free hydrogen fluoride (HF) during the initial activation step[2]. By decoupling the activation step from the fluorination step (which requires an exogenous fluoride source like Et₃N·3HF), the reaction avoids the highly acidic conditions that strip Boc-protecting groups, making it ideal for standard batch scale-up[1].
- **Continuous Flow (DAST):** Microreactor technology provides exceptional surface-area-to-volume ratios, enabling instantaneous heat dissipation. This allows hazardous reagents like DAST to be used safely at elevated temperatures (60–90 °C) with short residence times[3]. The rapid heating drives the sluggish C–F bond formation to completion, kinetically outcompeting the elimination pathway, while in-line quenching neutralizes HF immediately upon reactor exit[3].

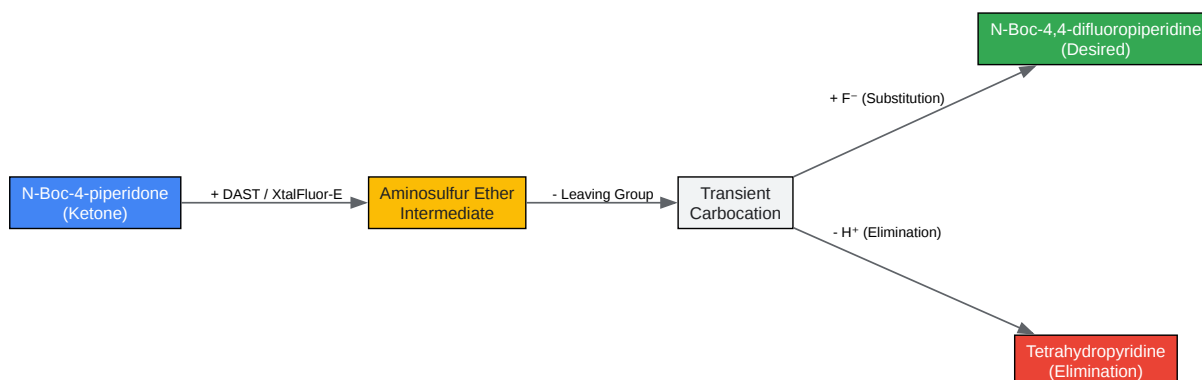

[Click to download full resolution via product page](#)

Mechanistic divergence in piperidone deoxofluorination showing product vs. elimination.

Quantitative Data Summary: Reagent & Platform Comparison

The following table summarizes the performance metrics of different deoxofluorination strategies for the synthesis of N-Boc-4,4-difluoropiperidine from N-Boc-4-piperidone.

Reaction Platform	Reagent	Temp (°C)	Reaction Time	Yield (%)	Elimination Byproduct (%)	Scalability / Safety Profile
Standard Batch	DAST	0 to 25	12 hours	45 - 55%	20 - 30%	Poor: High explosion risk >50 °C; poor exotherm control.
Standard Batch	XtalFluor-E	0 to 25	8 hours	75 - 82%	< 10%	Good: Reagent is crystalline and thermally stable.
Continuous Flow	DAST	60	10 mins	88 - 94%	< 5%	Excellent: Perfect thermal control; in-line HF quenching.

Experimental Protocols

Protocol A: Batch Synthesis using XtalFluor-E (Gram-Scale)

This protocol utilizes a self-validating buffering system. The addition of Et₃N·3HF acts as both the nucleophilic fluoride source and a buffer, preventing the reaction from becoming acidic enough to cleave the N-Boc protecting group.

Materials:

- N-Boc-4-piperidone (1.0 equiv, 10.0 g, 50.2 mmol)

- XtalFluor-E (1.5 equiv, 17.2 g, 75.3 mmol)
- Triethylamine trihydrofluoride (Et₃N·3HF) (2.0 equiv, 16.2 g, 100.4 mmol)
- Anhydrous Dichloromethane (DCM) (100 mL)

Step-by-Step Methodology:

- Preparation: Flame-dry a 250 mL round-bottom flask equipped with a magnetic stirrer and a nitrogen inlet. Add anhydrous DCM (100 mL) and Et₃N·3HF (16.2 g).
- Reagent Addition: Cool the solution to 0 °C using an ice-water bath. Add XtalFluor-E (17.2 g) portion-wise over 10 minutes. Stir for 15 minutes to ensure partial dissolution and complexation.
- Substrate Addition: Dissolve N-Boc-4-piperidone (10.0 g) in 20 mL of anhydrous DCM. Add this solution dropwise to the reaction mixture over 30 minutes via an addition funnel, maintaining the internal temperature below 5 °C.
- Reaction Progression: Remove the ice bath and allow the reaction to warm to room temperature (20–25 °C). Stir for 8 hours.
- Validation Checkpoint (In-Process): Withdraw a 0.1 mL aliquot, quench with saturated NaHCO₃, extract with DCM, and analyze via ¹⁹F NMR. The appearance of a characteristic multiplet at approximately -100 ppm confirms gem-difluoro formation. The reaction is complete when the starting material ketone signal in ¹H NMR disappears.
- Quenching & Workup: Cool the mixture to 0 °C and carefully quench by the dropwise addition of saturated aqueous NaHCO₃ (100 mL) until CO₂ evolution ceases and the pH reaches ~8.
- Isolation: Separate the organic layer. Extract the aqueous layer with DCM (2 × 50 mL). Wash the combined organic layers with brine, dry over anhydrous Na₂SO₄, filter, and concentrate under reduced pressure to yield the crude product. Purify via silica gel chromatography (Hexanes/EtOAc) to obtain N-Boc-4,4-difluoropiperidine as a white solid.

Protocol B: Continuous Flow Synthesis using DAST (Multi-Gram/Kilogram Scale)

This protocol leverages microreactor technology to safely utilize DAST at elevated temperatures. The self-validating nature of this system relies on the in-line purification column, which quantitatively traps hazardous byproducts before they exit the reactor[3].

System Setup:

- Pump A: 0.5 M solution of N-Boc-4-piperidone in anhydrous DCM.
- Pump B: 0.75 M solution of DAST in anhydrous DCM.
- Reactor: A 10 mL perfluoroalkoxy alkane (PFA) residence coil.
- Quench Column: An Omnifit® glass column packed with a 1:1 (w/w) mixture of anhydrous calcium carbonate (CaCO₃) and silica gel[3].

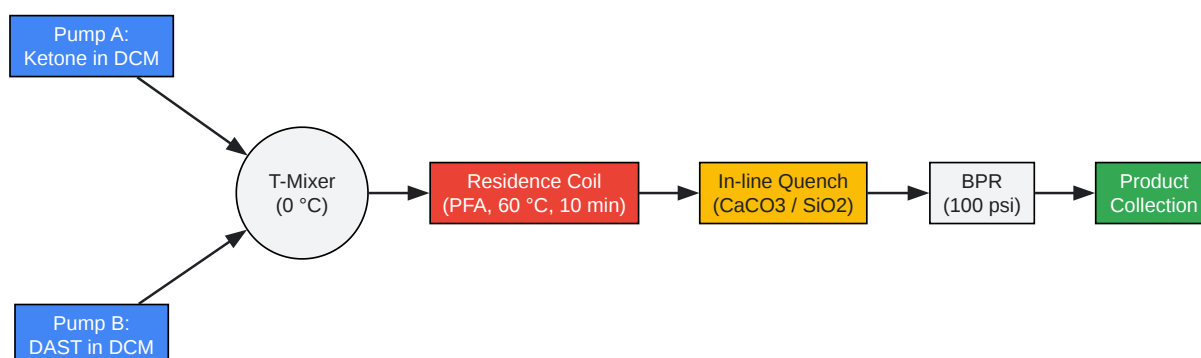

[Click to download full resolution via product page](#)

Continuous flow reactor schematic for safe, scalable DAST-mediated deoxofluorination.

Step-by-Step Methodology:

- **System Priming:** Flush the entire flow system with anhydrous DCM at a total flow rate of 2.0 mL/min for 10 minutes. Set the Back Pressure Regulator (BPR) to 100 psi to prevent solvent boiling.
- **Thermal Equilibration:** Submerge the T-mixer in an ice bath (0 °C) to control the initial exothermic complexation between the ketone and DAST. Submerge the 10 mL PFA residence coil in a heating bath set to 60 °C.
- **Steady-State Operation:** Engage Pump A and Pump B simultaneously at a flow rate of 0.5 mL/min each (Total flow = 1.0 mL/min). This provides a residence time of exactly 10 minutes in the heated coil.
- **In-Line Quenching:** Route the effluent directly through the Omnifit® column packed with CaCO₃/Silica. The CaCO₃ neutralizes the generated HF in situ, while the silica gel traps polar baseline impurities and unreacted DAST[3].
- **Validation Checkpoint (Effluent Mass Balance):** Because the in-line column traps all inorganic and highly polar species, the reactor effluent contains only the product and solvent. Evaporating a 5 mL fraction of the steady-state effluent should yield a crude mass that matches the theoretical yield (>90% purity by ¹H/¹⁹F NMR), validating the steady-state efficiency without the need for aqueous workup.
- **Collection:** Collect the steady-state output stream. Concentrate the solvent under reduced pressure to afford highly pure N-Boc-4,4-difluoropiperidine.

References

- Chen, H., Gurung, S. R., Li, L., Mancheno, D. E., Radtke, M. A., Ma, Z., Zhang, Z., Yang, W., Sun, L., & Xie, S. (2024). Development of an Efficient Synthesis toward a 4,4-Difluoropiperidine Intermediate Bearing a Pyridine N-Oxide Motif at the Carbon Stereocenter. *Synthesis*. 2

- Scholtz, C. (2015). The automated flow synthesis of fluorine containing organic compounds. University of Pretoria. [3](#)
- BenchChem. (n.d.). 4,4-Difluoroazepane Hydrochloride / Reagent Stability Profiles. [1](#)

Need Custom Synthesis?

BenchChem offers custom synthesis for rare earth carbides and specific isotopic labeling.

Email: info@benchchem.com or [Request Quote Online](#).

Sources

- [1. 4,4-Difluoroazepane Hydrochloride \[benchchem.com\]](#)
- [2. Thieme E-Journals - Synthesis / Abstract \[thieme-connect.com\]](#)
- [3. repository.up.ac.za \[repository.up.ac.za\]](#)
- To cite this document: BenchChem. [Scalable Synthesis of gem-Difluoro Piperidine Intermediates: Application Notes & Protocols]. BenchChem, [2026]. [Online PDF]. Available at: [<https://www.benchchem.com/product/b14779283/docs#scalable-synthesis-of-gem-difluoro-piperidine-intermediates-application-notes-protocols>]

Disclaimer & Data Validity:

The information provided in this document is for Research Use Only (RUO) and is strictly not intended for diagnostic or therapeutic procedures. While BenchChem strives to provide accurate protocols, we make no warranties, express or implied, regarding the fitness of this product for every specific experimental setup.

Technical Support: The protocols provided are for reference purposes. Unsure if this reagent suits your experiment?

Need Industrial/Bulk Grade? [Request Custom Synthesis Quote](#)

BenchChem

Our mission is to be the trusted global source of essential and advanced chemicals, empowering scientists and researchers to drive progress in science and industry.

Contact

Address: 3281 E Guasti Rd

Ontario, CA 91761, United States

Phone: (601) 213-4426

Email: info@benchchem.com

[Contact our Ph.D. Support Team for a compatibility check](#)