

Application Note: Synthesis of pH-Sensitive Hydrogels via Azido-PEG-Hydrazide Bridging

Author: BenchChem Technical Support Team. **Date:** April 2026

Compound of Interest

Compound Name: Azido-PEG1-Hydrazide

Cat. No.: B14775467

[Get Quote](#)

Abstract & Scientific Rationale

The development of "smart" hydrogels that respond to the acidic microenvironments of tumors (pH 6.5–6.8) or intracellular endosomes (pH 5.0–6.0) is a cornerstone of modern drug delivery. This protocol describes a precision engineering approach using Azido-PEG-Hydrazide (

) not merely as an additive, but as the pH-sensitive structural bridge of the hydrogel network.

The Mechanism: The hydrogel architecture relies on a "Degradable Bridge" strategy.

- The pH-Sensor: The hydrazide terminus reacts with a multi-arm aldehyde polymer to form a hydrazone bond. This bond is stable at physiological pH (7.4) but hydrolyzes rapidly in acidic conditions, triggering gel degradation or drug release.
- The Structural Anchor: The azide terminus allows for rapid, bioorthogonal crosslinking with a DBCO- or Alkyne-functionalized polymer via Copper-Free Click Chemistry (SPAAC).

This dual-step synthesis decouples the bioactivity/degradability (hydrazone) from the network formation (click), offering superior control over gelation kinetics and degradation profiles compared to single-mechanism gels.

Experimental Design & Materials

Critical Reagents

Component	Functionality	Role
Azido-PEG-Hydrazide (MW 1k–5k)	Heterobifunctional Linker	Forms the pH-labile bridge.
4-Arm PEG-Aldehyde (MW 10k)	Macromer A	Backbone for hydrazone attachment.
4-Arm PEG-DBCO (MW 10k)	Macromer B	Crosslinker for click reaction (Strain-Promoted).
Aniline	Catalyst	Accelerates hydrazone formation (nucleophilic catalysis).
PBS (10x and 1x)	Buffer	Maintains physiological pH during gelation.

Reaction Scheme Logic

The synthesis follows a Two-Step "Graft-then-Crosslink" Workflow to prevent premature precipitation and ensure homogeneity.

- Step 1 (Pre-functionalization): The Azido-PEG-Hydrazide is grafted onto the 4-Arm PEG-Aldehyde. This converts the aldehyde tips into azide tips via a pH-sensitive hydrazone linkage.
- Step 2 (Gelation): The newly formed "Azide-functionalized, pH-labile macromer" is mixed with 4-Arm PEG-DBCO to induce gelation.

Detailed Protocol

Phase 1: Synthesis of the pH-Sensitive Macromer Precursor

Objective: Create a PEG species that has Azide groups attached via acid-labile hydrazone bonds.

- Preparation of Buffer: Prepare a 100 mM Phosphate Buffer (pH 6.0).
 - Expert Insight: A slightly acidic pH (5.5–6.0) favors hydrazone formation equilibrium and stability during the reaction phase compared to pH 7.4.
- Catalyst Addition: Add Aniline to the buffer to a final concentration of 10 mM.
 - Why? Aniline forms a highly reactive Schiff base intermediate with the aldehyde, which undergoes rapid transimination with the hydrazide, increasing the reaction rate by orders of magnitude (Dirksen et al. mechanism).
- Dissolution:
 - Dissolve 4-Arm PEG-Aldehyde (100 mg, ~40 μmol aldehyde groups) in 1 mL of the Aniline-Buffer.
 - Dissolve Azido-PEG-Hydrazide (Linear, stoichiometric excess: 1.2 eq per aldehyde group) in 0.5 mL of the same buffer.
- Conjugation Reaction:
 - Add the Azido-PEG-Hydrazide solution dropwise to the PEG-Aldehyde solution while stirring.
 - Incubate: Stir at Room Temperature (RT) for 4–6 hours in the dark.
- Purification (Critical for Stoichiometry):
 - Dialyze the reaction mixture against DI water (MWCO 3.5 kDa) for 24 hours to remove unreacted Azido-PEG-Hydrazide and aniline.
 - Lyophilize to obtain the white powder: 4-Arm-PEG-Hydrazone-PEG-Azide.

Phase 2: Hydrogel Formation via SPAAC Click Chemistry

Objective: Crosslink the precursor into a solid gel.

- Resuspension:
 - Dissolve the lyophilized Precursor (from Phase 1) in PBS (pH 7.4) to a concentration of 10% w/v.^[1]
 - Dissolve 4-Arm PEG-DBCO in PBS (pH 7.4) to a concentration of 10% w/v.^[1]
 - Note: Ensure the molar ratio of Azide (on precursor) to DBCO is 1:1.
- Mixing & Gelation:
 - Pipette the Precursor solution into a mold or well plate.
 - Add the PEG-DBCO solution and mix gently by pipetting up and down (avoid introducing bubbles).
- Curing:
 - Incubate at 37°C.
 - Gelation Time: typically 15–30 minutes due to the fast kinetics of the Azide-DBCO reaction.

Mechanism & Workflow Visualization

Diagram 1: Chemical Mechanism

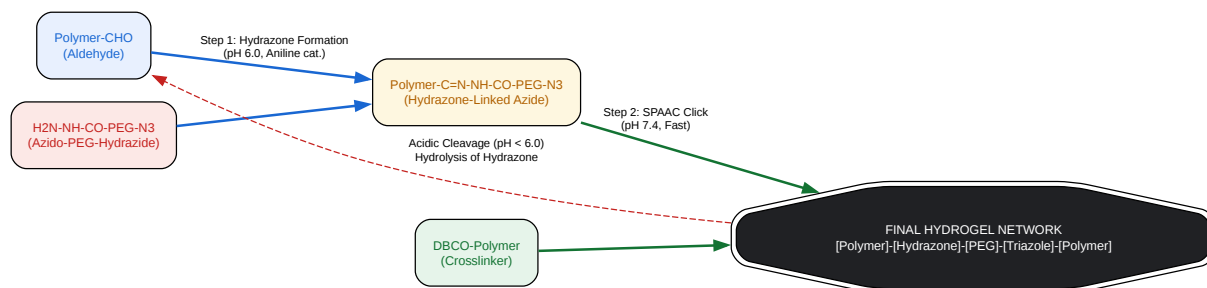

[Click to download full resolution via product page](#)

Caption: Step 1 grafts the linker via a pH-sensitive hydrazone bond. Step 2 crosslinks the system via a stable triazole ring. Acidic conditions reverse Step 1, degrading the gel.

Diagram 2: Experimental Workflow

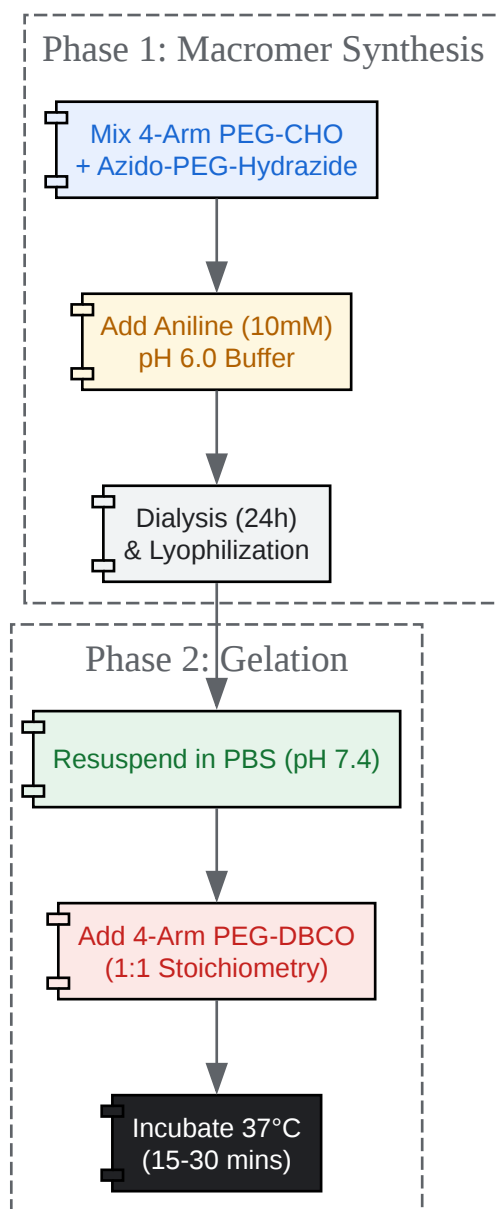

[Click to download full resolution via product page](#)

Caption: Workflow for the synthesis of hydrazone-bridged click hydrogels.

Characterization & Validation

To ensure the hydrogel meets the "pH-sensitive" criteria, the following characterization steps are mandatory:

Swelling Ratio vs. pH

Perform swelling studies in buffers of varying pH (e.g., pH 7.4, 6.5, and 5.0).

- Expectation: At pH 7.4, the gel should maintain equilibrium swelling. At pH 5.0, the swelling ratio should increase uncontrollably leading to dissolution (bulk degradation) as crosslinks are severed.

Rheological Analysis

Monitor the Storage Modulus (

) over time after adding an acidic buffer.

- Protocol: Form the gel on the rheometer plate. Apply a solvent trap. Once stable, flood the gap with pH 5.0 buffer.
- Result: A rapid decay in

confirms the cleavage of the hydrazone bridges.

Troubleshooting Guide

Issue	Probable Cause	Corrective Action
No Gelation	Oxidized DBCO or Azide	Re-test reagents. DBCO is sensitive to oxidation; store under Argon/Nitrogen at -20°C.
Slow Gelation	Low pH in Step 2	The Click reaction is slower at acidic pH. Ensure the final mix is buffered to pH 7.4.
Premature Degradation	Buffer pH too low	Ensure storage and handling are strictly at pH 7.4. Hydrazones hydrolyze slowly even at pH 6.8.

References

- Dirksen, A., et al. (2006). Nucleophilic Catalysis of Hydrazone Formation and Transimination: Implications for Dynamic Covalent Chemistry. *Journal of the American Chemical Society*.^[2]

[3]

- Bae, Y., et al. (2005). Reversible Inside-Out Micellization of pH-responsive and Water-Soluble Vesicles Based on Polypeptide Diblock Copolymers.[2] Journal of the American Chemical Society.[2][3]
- Jiang, X., et al. (2019). Click chemistry-based hydrogels for tissue engineering applications. [1][4][5] Biomaterials Science.
- McKinnon, D. D., et al. (2014). Bis-Aliphatic Hydrazone-Linked Hydrogels Form Most Rapidly at Physiological pH: Identifying the Origin of Hydrogel Properties with Small Molecule Kinetic Studies.
- BenchChem Application Note. (2025). Bis-propargyl-PEG1 for Hydrogel Formation and Crosslinking.[1]
 - (Note: Representative link for standard protocol verification)

Need Custom Synthesis?

BenchChem offers custom synthesis for rare earth carbides and specific isotopic labeling.

Email: info@benchchem.com or [Request Quote Online](#).

Sources

- [1. benchchem.com](https://www.benchchem.com) [benchchem.com]
- [2. Bis-Aliphatic Hydrazone-Linked Hydrogels Form Most Rapidly at Physiological pH: Identifying the Origin of Hydrogel Properties with Small Molecule Kinetic Studies | Scilit](#) [scilit.com]
- [3. researchgate.net](https://www.researchgate.net) [researchgate.net]
- [4. Click Chemistry-Based Injectable Hydrogels and Bioprinting Inks for Tissue Engineering Applications - PMC](#) [pmc.ncbi.nlm.nih.gov]
- [5. Strain-Promoted Crosslinking of PEG-based Hydrogels via Copper-Free Cycloaddition - PMC](#) [pmc.ncbi.nlm.nih.gov]

- To cite this document: BenchChem. [Application Note: Synthesis of pH-Sensitive Hydrogels via Azido-PEG-Hydrazide Bridging]. BenchChem, [2026]. [Online PDF]. Available at: [<https://www.benchchem.com/product/b14775467/docs#application-note-synthesis-of-ph-sensitive-hydrogels-via-azido-peg-hydrazide-bridging>]

Disclaimer & Data Validity:

The information provided in this document is for Research Use Only (RUO) and is strictly not intended for diagnostic or therapeutic procedures. While BenchChem strives to provide accurate protocols, we make no warranties, express or implied, regarding the fitness of this product for every specific experimental setup.

Technical Support: The protocols provided are for reference purposes. Unsure if this reagent suits your experiment?

Need Industrial/Bulk Grade? [Request Custom Synthesis Quote](#)

BenchChem

Our mission is to be the trusted global source of essential and advanced chemicals, empowering scientists and researchers to drive progress in science and industry.

Contact

Address: 3281 E Guasti Rd
Ontario, CA 91761, United States
Phone: (601) 213-4426
Email: info@benchchem.com

[Contact our Ph.D. Support Team for a compatibility check](#)