

Introduction: The Isomer Challenge in Dichlorobenzamide Analysis

Author: BenchChem Technical Support Team. **Date:** May 2026

Compound of Interest

Compound Name: 3,5-Dichloro-4-propoxybenzamide

Cat. No.: B14766494

[Get Quote](#)

Dichlorobenzamides are a class of chemical compounds encountered in various fields, most notably as the primary degradation product of the widely used herbicide dichlobenil (2,6-dichlorobenzonitrile).[1][2] Accurate identification and differentiation of dichlorobenzamide isomers are critical for environmental monitoring, toxicology studies, and drug development, as the position of the chlorine atoms on the benzene ring can significantly influence the compound's biological activity and degradation profile.

Mass spectrometry (MS), particularly coupled with gas chromatography (GC-MS), stands as the definitive analytical tool for this purpose.[3] While different isomers of dichlorobenzamide share the same molecular weight, their mass spectra exhibit unique fragmentation patterns under electron ionization (EI), providing a distinct "molecular fingerprint" for unambiguous identification.[4][5]

This guide provides an in-depth comparison of the EI mass spectrometry fragmentation patterns of dichlorobenzamide isomers. We will explore the core fragmentation mechanisms, present a comparative analysis of key isomers, and provide a validated experimental protocol for reproducible data acquisition. This document is intended for researchers, scientists, and drug development professionals who require a deep, mechanistic understanding of how these molecules behave in the mass spectrometer.

Pillar 1: Fundamentals of Dichlorobenzamide Fragmentation

To interpret the mass spectra of dichlorobenzamides, one must first understand the fundamental principles governing the fragmentation of halogenated aromatic amides under electron ionization (EI).

The Ionization Process

In EI-MS, high-energy electrons (typically 70 eV) bombard the analyte molecule.^{[6][7]} This process is energetic enough to eject an electron from the molecule, forming a positively charged radical ion known as the molecular ion ($M+\bullet$).^{[5][8]} This molecular ion is often energetically unstable and rapidly undergoes a series of fragmentation reactions to produce smaller, more stable ions.^[9] The key to spectral interpretation is understanding these fragmentation pathways.

Characteristic Features of Dichlorinated Compounds

A hallmark of compounds containing chlorine is the presence of distinct isotopic patterns. Chlorine has two stable isotopes, ^{35}Cl ($\approx 75.8\%$ abundance) and ^{37}Cl ($\approx 24.2\%$ abundance). For a molecule with two chlorine atoms, like dichlorobenzamide, this results in a characteristic cluster of peaks for the molecular ion and any chlorine-containing fragments:

- $M+$ peak: Contains two ^{35}Cl atoms.
- $M+2$ peak: Contains one ^{35}Cl and one ^{37}Cl atom. Its intensity is approximately 65% of the $M+$ peak.
- $M+4$ peak: Contains two ^{37}Cl atoms. Its intensity is approximately 10% of the $M+$ peak.

This triplet-like pattern is a powerful diagnostic tool for confirming the presence of two chlorine atoms in an ion.^[10]

Core Fragmentation Pathways

The fragmentation of dichlorobenzamides is primarily driven by the amide functional group and the dichlorinated aromatic ring. Key reactions include:

- **Alpha (α)-Cleavage:** This is a common fragmentation pathway for amides.[9][11] It involves the cleavage of the bond between the carbonyl carbon and the aromatic ring. This results in the formation of a stable dichlorobenzoyl cation or the loss of the amide group.
- **Loss of Neutral Molecules:** The molecular ion can stabilize by expelling small, neutral molecules. For dichlorobenzamides, common losses include:
 - **Loss of CO (Carbon Monoxide):** A frequent fragmentation pathway for carbonyl-containing compounds.
 - **Loss of Cl• (Chlorine Radical):** The C-Cl bond can break, leading to the loss of a chlorine radical.[10]
 - **Loss of HCl (Hydrogen Chloride):** A rearrangement reaction can lead to the elimination of a neutral HCl molecule.[10]
- **Ring Fragmentation:** The aromatic ring itself can break apart, though this typically results in lower-mass fragments of lower diagnostic value compared to the initial, more characteristic losses.

Pillar 2: Comparative Fragmentation Analysis of Dichlorobenzamide Isomers

The substitution pattern of the chlorine atoms significantly influences the relative abundance of fragment ions, providing the basis for isomer differentiation. Here, we compare the fragmentation of 2,6-dichlorobenzamide and 3,5-dichlorobenzamide.

Case Study: 2,6-Dichlorobenzamide

2,6-Dichlorobenzamide is a significant metabolite of the herbicide dichlobenil.[12] Its mass spectrum is well-characterized and available in spectral libraries.[13]

Table 1: Key Fragment Ions in the EI Mass Spectrum of 2,6-Dichlorobenzamide

m/z (mass-to-charge)	Proposed Fragment Ion	Proposed Structure	Neutral Loss	Relative Intensity
191/189	[M] ⁺ • (Molecular Ion)	C ₇ H ₅ Cl ₂ NO ⁺ •	-	Moderate
175/173	[M - NH ₂] ⁺	[C ₇ H ₄ Cl ₂ O] ⁺	•NH ₂	High
145/147	[M - NH ₂ - CO] ⁺ •	[C ₆ H ₄ Cl ₂] ⁺ •	CO	Moderate
138	[M - Cl - NH ₂] ⁺	[C ₇ H ₄ ClO] ⁺	Cl•, •NH ₂	Low
110	[C ₆ H ₄ Cl] ⁺	[C ₆ H ₄ Cl] ⁺	Cl•, CO, •NH ₂	Moderate

The fragmentation of 2,6-dichlorobenzamide is dominated by the initial formation of the dichlorobenzoyl cation at m/z 173/175. This is a highly stable acylium ion. Subsequent loss of carbon monoxide (CO) leads to the dichlorophenyl cation at m/z 145/147.

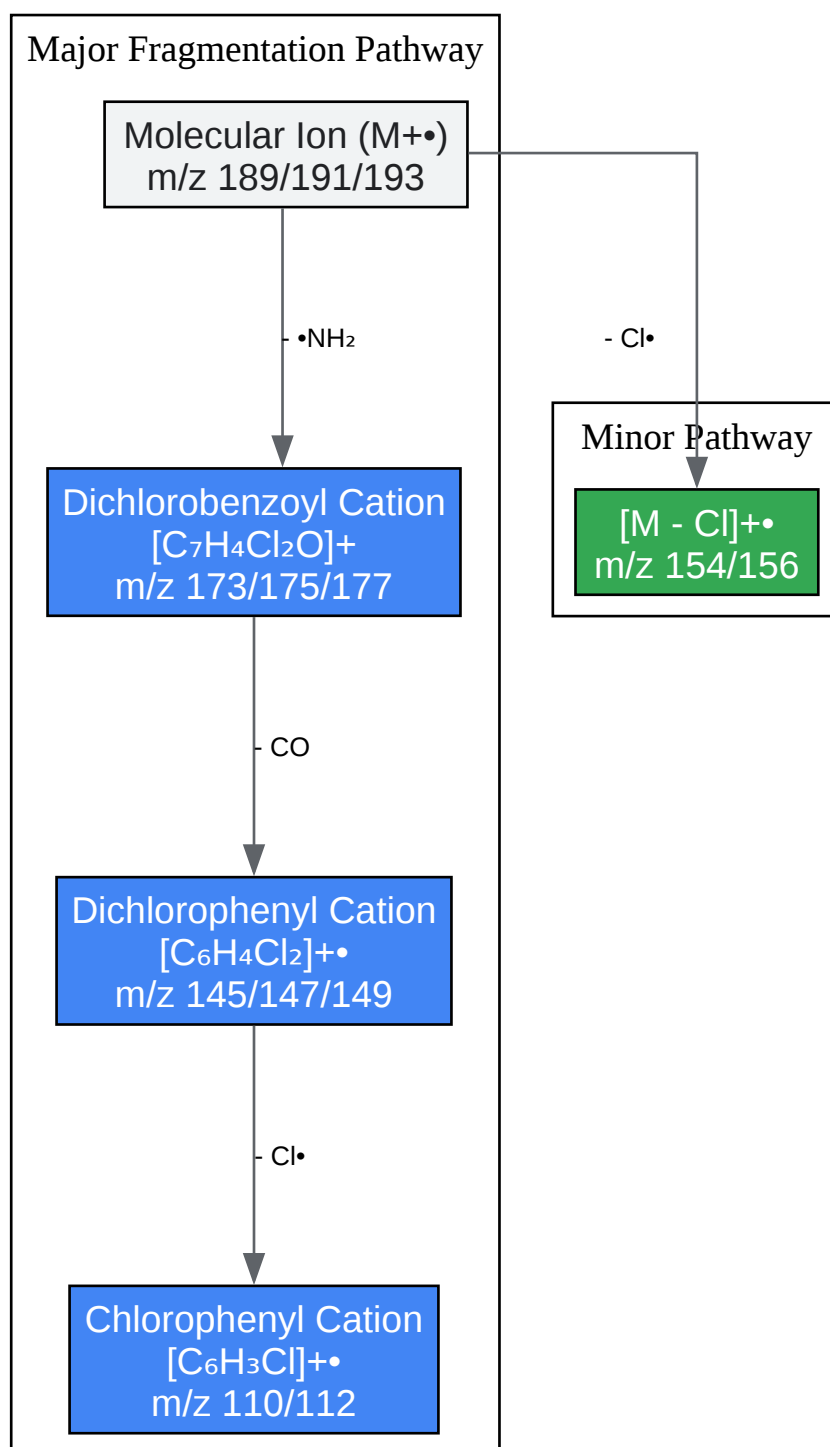

[Click to download full resolution via product page](#)

Caption: Proposed fragmentation pathway for 2,6-Dichlorobenzamide.

Case Study: 3,5-Dichlorobenzamide

While a direct experimental spectrum for 3,5-dichlorobenzamide is less commonly published, its fragmentation can be predicted based on established principles. The stability of the resulting fragment ions will differ from the 2,6-isomer due to the lack of ortho-effects.

Table 2: Predicted Key Fragment Ions for 3,5-Dichlorobenzamide

m/z (mass-to-charge)	Proposed Fragment Ion	Proposed Structure	Neutral Loss	Predicted Relative Intensity
191/189	[M] ^{+•} (Molecular Ion)	C ₇ H ₅ Cl ₂ NO ^{+•}	-	Moderate
175/173	[M - NH ₂] ⁺	[C ₇ H ₄ Cl ₂ O] ⁺	•NH ₂	High
145/147	[M - NH ₂ - CO] ^{+•}	[C ₆ H ₄ Cl ₂] ^{+•}	CO	High
110	[C ₆ H ₄ Cl] ⁺	[C ₆ H ₄ Cl] ⁺	Cl•, CO, •NH ₂	Moderate

For the 3,5-isomer, the formation of the dichlorobenzoyl cation (m/z 173/175) and its subsequent decarbonylation product (m/z 145/147) are also expected to be major pathways. However, the key differentiator often lies in the relative intensities of these fragments. Without the steric hindrance from chlorine atoms in the ortho positions, the stability of the dichlorophenyl cation (m/z 145/147) may be greater, potentially making it the base peak in the spectrum, in contrast to the 2,6-isomer where the dichlorobenzoyl cation is often dominant.

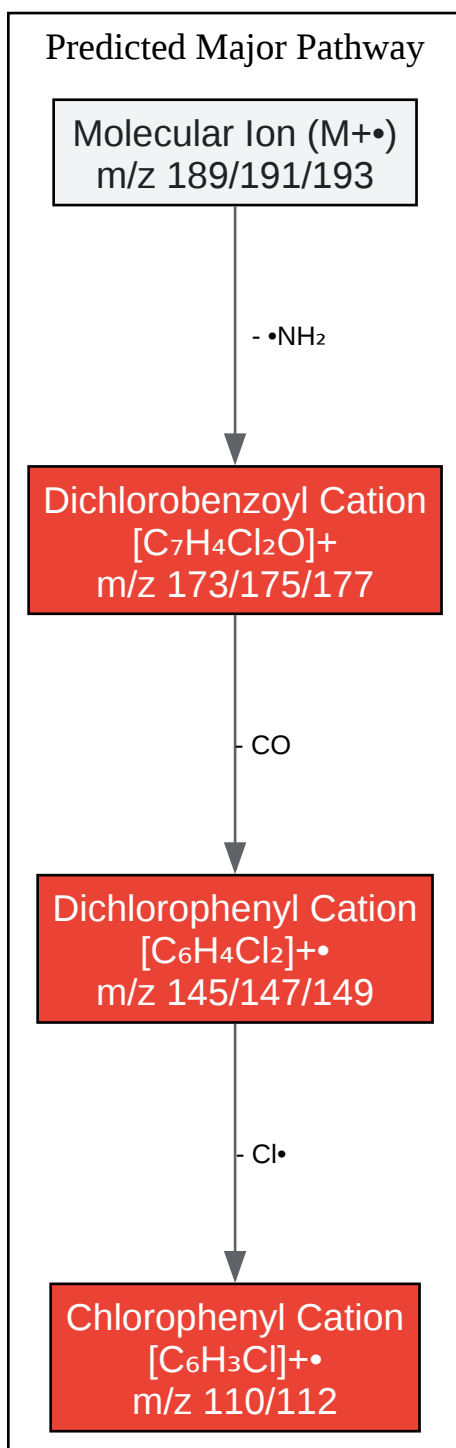

[Click to download full resolution via product page](#)

Caption: Predicted fragmentation pathway for 3,5-Dichlorobenzamide.

Pillar 3: A Self-Validating Experimental Protocol for GC-MS Analysis

Reproducible and high-quality data are paramount. This protocol describes a robust method for the analysis of dichlorobenzamides using GC-MS. The inclusion of quality control checks ensures the validity of the results.

Objective

To acquire high-quality, reproducible electron ionization mass spectra of dichlorobenzamide isomers for identification and comparison.

Methodology

- Standard Preparation:
 1. Prepare a 1 mg/mL stock solution of each dichlorobenzamide isomer in a suitable solvent (e.g., ethyl acetate or methanol).
 2. Perform serial dilutions to create working standards at concentrations ranging from 1 µg/mL to 10 µg/mL. Causality: Working in this concentration range prevents detector saturation while ensuring adequate signal intensity.
- GC-MS Instrumentation and Parameters:
 - Gas Chromatograph: Agilent 8890 GC or equivalent.
 - Mass Spectrometer: Agilent 5977B MSD or equivalent.
 - Injector: Split/Splitless inlet. Operate in splitless mode for 1 minute to maximize analyte transfer to the column for trace analysis.
 - Injection Volume: 1 µL.
 - Liner: Use a deactivated, single-taper splitless liner. Causality: An inert liner is crucial to prevent the thermal degradation of the amide functional group.

- GC Column: HP-5ms (30 m x 0.25 mm x 0.25 μ m) or equivalent 5% phenyl-methylpolysiloxane column. Causality: This column provides excellent separation for a wide range of semi-volatile aromatic compounds.
- Oven Program:
 - Initial Temperature: 100 °C, hold for 1 minute.
 - Ramp: 15 °C/min to 280 °C.
 - Hold: 5 minutes at 280 °C.
- Carrier Gas: Helium at a constant flow of 1.2 mL/min.
- Mass Spectrometer Parameters:
 - Ion Source: Electron Ionization (EI).
 - Ionization Energy: 70 eV. Causality: This is the standard energy used for generating mass spectra, allowing for direct comparison with established libraries like NIST.[6]
 - Source Temperature: 230 °C.
 - Quadrupole Temperature: 150 °C.
 - Mass Scan Range: m/z 40 - 400. Causality: This range comfortably covers the molecular ion and all expected major fragments.
 - Solvent Delay: 4 minutes. Causality: This prevents the high concentration of the injection solvent from entering and saturating the MS detector.
- Data Acquisition and Validation Workflow:

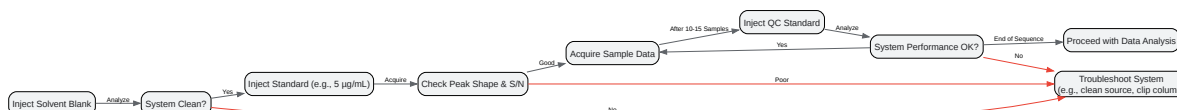

[Click to download full resolution via product page](#)

Caption: A self-validating workflow for GC-MS data acquisition.

Data Analysis

- Identify the chromatographic peak for the dichlorobenzamide isomer.
- Extract the mass spectrum from the apex of the peak.
- Subtract the background spectrum from an adjacent region of the chromatogram to obtain a clean spectrum.
- Identify the molecular ion cluster (M^+ , $M+2$, $M+4$) to confirm the molecular weight and presence of two chlorine atoms.
- Identify the major fragment ions and compare their m/z values and relative intensities to reference spectra or the patterns discussed in this guide to confirm the isomer's identity.

Conclusion

The differentiation of dichlorobenzamide isomers via mass spectrometry is a clear and achievable analytical goal. While the primary fragmentation pathways—notably the formation of the dichlorobenzoyl cation—are common across isomers, the key to their unique identification lies in the subtle yet significant differences in the relative intensities of their fragment ions. The steric and electronic effects imparted by the chlorine substitution pattern directly influence fragment ion stability, creating a distinct and reproducible mass spectral fingerprint. By

employing a robust and well-validated GC-MS protocol, researchers can confidently identify these compounds, ensuring data integrity for critical applications in environmental and pharmaceutical sciences.

References

- Zambonin, C., & Aresta, A. (2005). GC-MS analysis of dichlobenil and its metabolites in groundwater. *Talanta*, 68(1), 146-54. [\[Link\]](#)
- Sørensen, S. R., et al. (2003). An analytical method for the determination of 2,6-dichlorobenzamide and its degradation products in water samples using solid-phase extraction followed by liquid chromatography-tandem mass spectrometry. *Journal of Chromatography A*, 1003(1-2), 183-192. [\[Link\]](#)
- Zwank, L., et al. (2005). A method based on gas chromatography/mass spectrometry-negative ion chemical ionization detection for the determination of 3,3'-dichlorobenzidine (DCB)-hemoglobin adducts. *Journal of Chromatography B*, 824(1-2), 1-8. [\[Link\]](#)
- PubChem. (n.d.). 2,6-Dichlorobenzamide. National Center for Biotechnology Information. [\[Link\]](#)
- Scribd. (n.d.). Halogen Fragmentation in Mass Spectrometry. [\[Link\]](#)
- University of Calgary. (n.d.). Fragmentation Patterns. University of Calgary Chemistry Department. [\[Link\]](#)
- ResearchGate. (n.d.). Determination of 2,6-dichlorobenzamide and its degradation products in water samples using solid-phase extraction followed by liquid chromatography-tandem mass spectrometry. [\[Link\]](#)
- NIST. (n.d.). Benzamide, 2,6-dichloro-. NIST Chemistry WebBook. [\[Link\]](#)
- NIST. (n.d.). Gas Chromatography data for Benzamide, 2,6-dichloro-. NIST Chemistry WebBook. [\[Link\]](#)
- Chemistry LibreTexts. (2023). Mass Spectrometry - Fragmentation Patterns. [\[Link\]](#)

- Clark, J. (n.d.). Fragmentation patterns in the mass spectra of organic compounds. Chemguide. [[Link](#)]
- NIST. (n.d.). IR Spectrum for Benzamide, 2,6-dichloro-. NIST Chemistry WebBook. [[Link](#)]
- Widener University. (n.d.). Fragmentation Mechanisms. Intro to Mass Spectrometry. [[Link](#)]
- PubChem. (n.d.). Dichlobenil. National Center for Biotechnology Information. [[Link](#)]
- Wikipedia. (n.d.). Fragmentation (mass spectrometry). [[Link](#)]
- Animal Health Laboratory, University of Guelph. (2019). GC/MS-LC/MS multi-residue method. [[Link](#)]
- Emory University. (n.d.). Mass Spectrometry Ionization Methods. Chemistry at Emory. [[Link](#)]
- Kofoed, J. (n.d.). Fragmentation mechanisms in electron impact mass spectrometry. University of Copenhagen.
- eGyanKosh. (n.d.). Mass Spectrometry: Fragmentation Patterns. [[Link](#)]

Need Custom Synthesis?

BenchChem offers custom synthesis for rare earth carbides and specific isotopic labeling.

Email: info@benchchem.com or [Request Quote Online](#).

Sources

- 1. GC-MS analysis of dichlobenil and its metabolites in groundwater - PubMed [pubmed.ncbi.nlm.nih.gov]
- 2. researchgate.net [researchgate.net]
- 3. uoguelph.ca [uoguelph.ca]
- 4. idc-online.com [idc-online.com]
- 5. chemguide.co.uk [chemguide.co.uk]
- 6. benchchem.com [benchchem.com]

- [7. Mass Spectrometry Ionization Methods \[chemistry.emory.edu\]](#)
- [8. thiele.ruc.dk \[thiele.ruc.dk\]](#)
- [9. Fragmentation \(mass spectrometry\) - Wikipedia \[en.wikipedia.org\]](#)
- [10. scribd.com \[scribd.com\]](#)
- [11. chem.libretexts.org \[chem.libretexts.org\]](#)
- [12. 2,6-Dichlorobenzamide | C7H5Cl2NO | CID 16183 - PubChem \[pubchem.ncbi.nlm.nih.gov\]](#)
- [13. Benzamide, 2,6-dichloro- \[webbook.nist.gov\]](#)
- To cite this document: BenchChem. [Introduction: The Isomer Challenge in Dichlorobenzamide Analysis]. BenchChem, [2026]. [Online PDF]. Available at: [\[https://www.benchchem.com/product/b14766494/docs#introduction-the-isomer-challenge-in-dichlorobenzamide-analysis\]](https://www.benchchem.com/product/b14766494/docs#introduction-the-isomer-challenge-in-dichlorobenzamide-analysis)

Disclaimer & Data Validity:

The information provided in this document is for Research Use Only (RUO) and is strictly not intended for diagnostic or therapeutic procedures. While BenchChem strives to provide accurate protocols, we make no warranties, express or implied, regarding the fitness of this product for every specific experimental setup.

Technical Support: The protocols provided are for reference purposes. Unsure if this reagent suits your experiment?

Need Industrial/Bulk Grade? [Request Custom Synthesis Quote](#)

BenchChem

Our mission is to be the trusted global source of essential and advanced chemicals, empowering scientists and researchers to drive progress in science and industry.

Contact

Address: 3281 E Guasti Rd

Ontario, CA 91761, United States

Phone: (601) 213-4426

Email: info@benchchem.com

Contact our Ph.D. Support Team for a compatibility check