

GC-MS Analysis of Cyclooctadecane: A Technical Guide

Author: BenchChem Technical Support Team. **Date:** May 2026

Compound of Interest

Compound Name: Cyclooctadecane

CAS No.: 296-18-4

Cat. No.: B14757594

[Get Quote](#)

This guide provides a comprehensive overview of the Gas Chromatography-Mass Spectrometry (GC-MS) analysis of **Cyclooctadecane** (C₁₈H₃₆). It is intended for researchers, scientists, and professionals in drug development and related fields who utilize GC-MS for the identification and quantification of long-chain cycloalkanes. This document outlines detailed experimental protocols, data interpretation, and expected fragmentation patterns.

Introduction

Cyclooctadecane is a saturated cyclic hydrocarbon with the chemical formula C₁₈H₃₆ and a molecular weight of approximately 252.48 g/mol ^[1]. As a large, non-polar molecule, it is well-suited for analysis by Gas Chromatography-Mass Spectrometry (GC-MS), a powerful technique that combines the superior separation capabilities of gas chromatography with the sensitive and specific detection provided by mass spectrometry. This combination allows for the effective separation of **Cyclooctadecane** from complex matrices and its unambiguous identification based on its unique mass spectrum and retention time.

Experimental Protocols

A successful GC-MS analysis relies on meticulous sample preparation and optimized instrument parameters. The following section details a generalized protocol adaptable to most standard GC-MS systems.

Sample Preparation

Proper sample preparation is critical for achieving accurate and reproducible results.

- **Standard Solution:** Prepare a stock solution by accurately weighing a known amount of pure **Cyclooctadecane** standard and dissolving it in a high-purity volatile solvent such as n-hexane or dichloromethane to a concentration of 1 mg/mL.
- **Serial Dilutions:** Create a series of working standards by performing serial dilutions of the stock solution to generate a calibration curve for quantitative analysis.
- **Sample Extraction:** For samples in a complex matrix (e.g., plant extracts, biological fluids), a liquid-liquid extraction or solid-phase extraction (SPE) may be necessary to isolate the non-polar components, including **Cyclooctadecane**.
- **Final Preparation:** Transfer the final diluted standard or prepared sample into a 2 mL glass GC vial with a screw cap and septum for analysis.

GC-MS Instrumentation and Conditions

The following instrumental parameters are recommended. Optimization may be required based on the specific instrument and analytical goals.[\[2\]](#)[\[3\]](#)[\[4\]](#)[\[5\]](#)

Parameter	Recommended Setting
Gas Chromatograph	System equipped with a capillary column inlet (e.g., Split/Splitless)
Column	Elite-1, HP-5MS, or equivalent (30 m x 0.25 mm ID, 0.25 μ m film thickness)[2][5]
Carrier Gas	Helium (99.999% purity) at a constant flow rate of 1.0 mL/min[2][3]
Injection Mode	Split (e.g., 10:1 or 50:1 ratio) or Splitless, depending on concentration[2][4]
Injection Volume	1 μ L
Injector Temperature	250 - 280 $^{\circ}$ C[2]
Oven Program	Initial temp 50-80 $^{\circ}$ C, hold for 2 min, ramp at 5-10 $^{\circ}$ C/min to 280-300 $^{\circ}$ C, hold for 5-10 min
Mass Spectrometer	Quadrupole or Ion Trap Mass Analyzer
Ionization Mode	Electron Ionization (EI) at 70 eV[3]
Ion Source Temp.	230 - 280 $^{\circ}$ C[2][3]
Mass Scan Range	40 - 550 amu[3]
Data Acquisition	Full Scan Mode

Data Analysis and Interpretation

Retention Time

The retention time (tR) is the time it takes for a compound to travel from the injector to the detector.[6] Under consistent chromatographic conditions, the retention time for **Cyclooctadecane** will be highly reproducible and serves as a primary identifier. It is influenced by factors such as the oven temperature program, carrier gas flow rate, and the column's stationary phase.[6][7] For positive identification, the retention time of the analyte peak in a sample should match that of a pure **Cyclooctadecane** standard run under identical conditions.

Mass Spectrum Interpretation

Electron Ionization (EI) of alkanes and cycloalkanes typically results in extensive fragmentation. The molecular ion peak (M⁺) for **Cyclooctadecane** at m/z 252 may be present, but often with low intensity.[8] The fragmentation pattern is characterized by clusters of peaks separated by 14 mass units, corresponding to the sequential loss of methylene (-CH₂-) groups.[8] The interpretation of the mass spectrum involves comparing the fragmentation pattern of the unknown peak to a reference spectrum from a library like NIST or Wiley.

Expected Results

The GC-MS analysis of **Cyclooctadecane** will produce a chromatogram with a distinct peak at its characteristic retention time and a corresponding mass spectrum.

Quantitative Data Summary

For quantitative analysis, a calibration curve is constructed by plotting the peak area of a characteristic ion against the concentration of the prepared standards. The concentration of **Cyclooctadecane** in a sample can then be determined from this curve.

Table 1: Expected Mass Spectral Data for **Cyclooctadecane**

Attribute	Value (m/z)	Description
Molecular Formula	C18H36	-
Molecular Weight	252.48	-
Molecular Ion (M ⁺)	252	Parent ion; may have low abundance.
Key Fragments	223, 195, 167, 139, 111, 97, 83, 69, 55, 41	Series of fragments resulting from the loss of successive C ₂ H ₅ , C ₄ H ₉ , and other alkyl radicals. The pattern shows clusters of ions separated by 14 amu (-CH ₂ -).

| Base Peak | 41, 55, or 69 | Typically one of the smaller, more stable carbocation fragments. |

Visualizations

Diagrams are provided below to illustrate the experimental workflow and a plausible mass fragmentation pathway for **Cyclooctadecane**.



[Click to download full resolution via product page](#)

Caption: Experimental workflow for the GC-MS analysis of **Cyclooctadecane**.

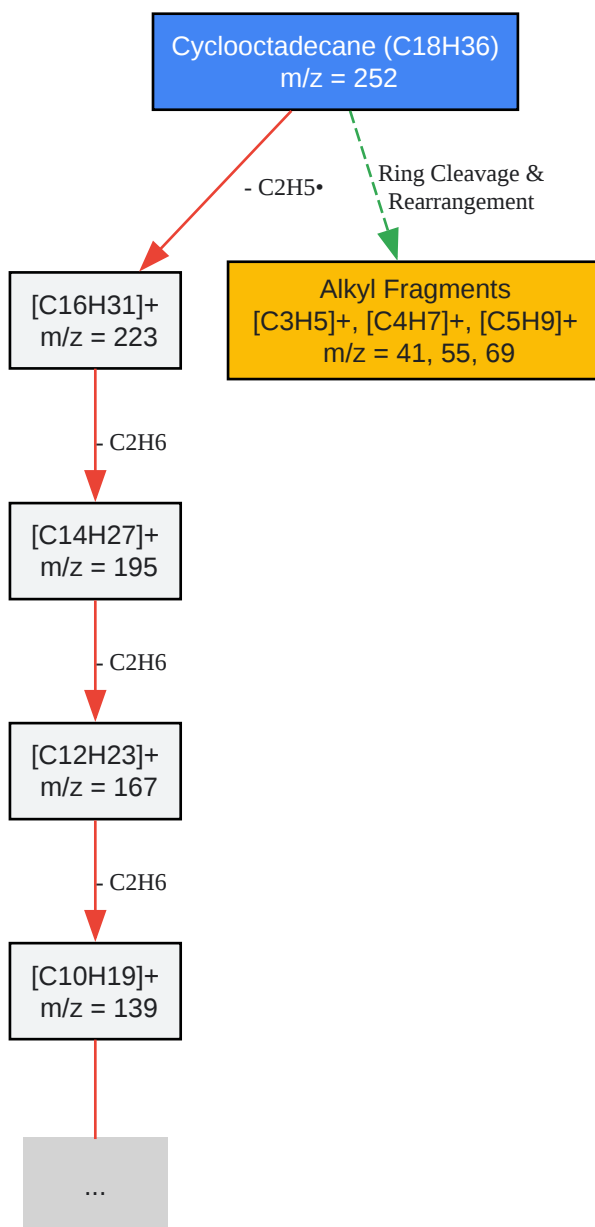

[Click to download full resolution via product page](#)

Caption: Proposed mass fragmentation pathway for **Cyclooctadecane** under EI conditions.

Need Custom Synthesis?

BenchChem offers custom synthesis for rare earth carbides and specific isotopic labeling.

Email: info@benchchem.com or [Request Quote Online](#).

References

- [1. Cyclooctadecane \[webbook.nist.gov\]](#)
- [2. scholarsresearchlibrary.com \[scholarsresearchlibrary.com\]](#)
- [3. mdpi.com \[mdpi.com\]](#)
- [4. thepharmajournal.com \[thepharmajournal.com\]](#)
- [5. researchgate.net \[researchgate.net\]](#)
- [6. Retention Time & Relative Retention Time in GC | Phenomenex \[phenomenex.com\]](#)
- [7. lotusinstruments.com \[lotusinstruments.com\]](#)
- [8. chem.libretexts.org \[chem.libretexts.org\]](#)
- To cite this document: BenchChem. [GC-MS Analysis of Cyclooctadecane: A Technical Guide]. BenchChem, [2026]. [Online PDF]. Available at: [\[https://www.benchchem.com/product/b14757594/docs#gc-ms-analysis-of-cyclooctadecane-a-technical-guide\]](https://www.benchchem.com/product/b14757594/docs#gc-ms-analysis-of-cyclooctadecane-a-technical-guide)

Disclaimer & Data Validity:

The information provided in this document is for Research Use Only (RUO) and is strictly not intended for diagnostic or therapeutic procedures. While BenchChem strives to provide accurate protocols, we make no warranties, express or implied, regarding the fitness of this product for every specific experimental setup.

Technical Support: The protocols provided are for reference purposes. Unsure if this reagent suits your experiment?

Need Industrial/Bulk Grade? [Request Custom Synthesis Quote](#)

BenchChem

Our mission is to be the trusted global source of essential and advanced chemicals, empowering scientists and researchers to drive progress in science and industry.

Contact

Address: 3281 E Guasti Rd

Ontario, CA 91761, United States

Phone: (601) 213-4426

Email: info@benchchem.com

[Contact our Ph.D. Support Team for a compatibility check](#)