

Technical Support Center: T-3861174 Dose-Response Curve Optimization

Author: BenchChem Technical Support Team. **Date:** April 2026

Compound of Interest

Compound Name: T-3861174

Cat. No.: B14754603

[Get Quote](#)

Notice: Information regarding the specific compound "**T-3861174**" is not available in the public domain. The following technical support guide is a generalized framework based on common challenges and methodologies in dose-response curve optimization for novel therapeutic compounds. Researchers should adapt these principles to their specific experimental findings for **T-3861174**.

Frequently Asked Questions (FAQs)

Q1: We are observing a high degree of variability in our dose-response assays for **T-3861174**. What are the potential causes and how can we troubleshoot this?

A1: High variability in dose-response assays can stem from several factors. Systematically investigate the following:

- Cell-Based Assay Variability:
 - Cell Line Stability: Ensure you are using a stable cell line with consistent passage numbers. Genetic drift in cultured cells can alter their response to therapeutic agents.

- Cell Seeding Density: Inconsistent cell numbers at the start of the experiment will lead to variable results. Optimize and strictly control seeding density.
- Edge Effects in Plates: Cells in the outer wells of a microplate can behave differently due to temperature and humidity gradients. Avoid using the outermost wells for experimental data or use appropriate plate-sealing techniques.
- Compound Handling:
 - Solubility: Confirm the solubility of **T-3861174** in your chosen solvent and that it remains soluble in the final assay medium. Precipitation of the compound will lead to inaccurate dosing.
 - Storage and Stability: Ensure the compound is stored under recommended conditions to prevent degradation. Perform stability tests if necessary.
- Assay Protocol:
 - Incubation Times: Adhere to optimized and consistent incubation times for both compound treatment and assay reagents.
 - Reagent Preparation: Prepare fresh reagents and ensure thorough mixing.

Q2: The dose-response curve for **T-3861174** is not reaching a complete sigmoidal shape (i.e., no upper or lower plateau). What does this indicate?

A2: An incomplete sigmoidal curve can suggest several possibilities:

- Concentration Range: The concentration range tested may be too narrow. You may need to test higher concentrations to observe the maximal effect (upper plateau) or lower concentrations to see the minimal effect (lower plateau).
- Compound Efficacy: **T-3861174** may be a partial agonist or antagonist, meaning it does not produce a maximal response even at saturating concentrations.
- Off-Target Effects or Toxicity: At very high concentrations, the compound might be causing non-specific toxicity, leading to a drop in the response that confounds the expected sigmoidal curve. Consider performing a cytotoxicity assay in parallel.

Q3: How do we determine the optimal concentration range for our initial dose-response experiments with **T-3861174**?

A3: A common approach is to perform a wide-range, logarithmic-scale dose-response experiment. For example, you could start with a range from 1 nM to 100 μ M, with 10-fold dilutions. This will help you identify the approximate range of concentrations where the biological activity of **T-3861174** occurs. Subsequent experiments can then focus on a narrower range of concentrations with smaller dilution steps (e.g., 2-fold or 3-fold dilutions) around the initially identified active range to precisely determine the EC50/IC50.

Troubleshooting Guides

Problem: Non-Reproducible EC50/IC50 Values

Potential Cause	Troubleshooting Steps
Inconsistent Cell Passage Number	Use cells within a defined, narrow passage number range for all experiments.
Variable Reagent Quality	Use reagents from the same lot number where possible. Prepare fresh solutions for each experiment.
Pipetting Errors	Calibrate pipettes regularly. Use reverse pipetting for viscous solutions.
Inconsistent Incubation Conditions	Ensure consistent temperature, CO ₂ , and humidity levels in the incubator.

Problem: Low Assay Signal-to-Noise Ratio

Potential Cause	Troubleshooting Steps
Suboptimal Assay Reagent Concentration	Titrate key assay reagents (e.g., antibodies, substrates) to determine the optimal concentration for your specific assay conditions.
High Background Signal	Identify and minimize sources of background, such as non-specific binding or autofluorescence of the compound or plate material.
Insufficient Incubation Time	Optimize the incubation time for the detection reagent to allow for sufficient signal development.

Experimental Protocols

General Protocol for a Cell-Based Dose-Response Assay

- Cell Seeding:
 - Culture cells to be used in the assay to approximately 80% confluency.
 - Trypsinize and count the cells.
 - Seed the cells into a 96-well plate at a pre-determined optimal density and allow them to adhere overnight in a CO2 incubator at 37°C.
- Compound Preparation and Dosing:
 - Prepare a stock solution of **T-3861174** in a suitable solvent (e.g., DMSO).
 - Perform a serial dilution of the stock solution to create a range of working concentrations.
 - Remove the culture medium from the cells and add the medium containing the different concentrations of **T-3861174**. Include a vehicle control (medium with solvent only).
- Incubation:

- Incubate the plate for a predetermined duration based on the expected mechanism of action of **T-3861174**.
- Assay Readout:
 - Perform the chosen assay to measure the biological response (e.g., cell viability assay, reporter gene assay, protein expression analysis).
 - Read the plate using a suitable plate reader.
- Data Analysis:
 - Subtract the background readings.
 - Normalize the data to the vehicle control.
 - Plot the normalized response versus the log of the compound concentration.
 - Fit the data to a four-parameter logistic regression model to determine the EC50/IC50.

Visualizations

Logical Workflow for Dose-Response Curve Optimization

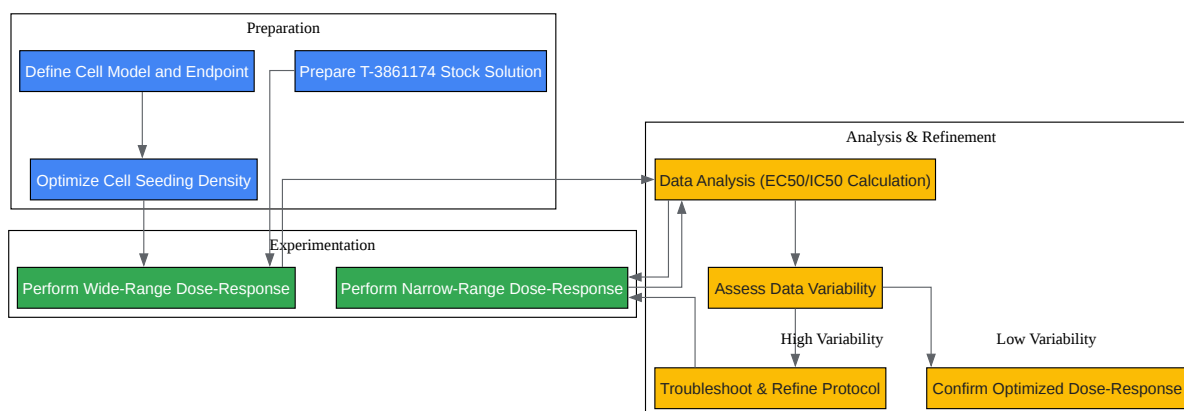

[Click to download full resolution via product page](#)

Caption: A logical workflow for optimizing dose-response experiments.

Hypothetical Signaling Pathway Inhibition by T-3861174

This diagram illustrates a hypothetical scenario where **T-3861174** inhibits a key kinase in a cancer-related signaling pathway.

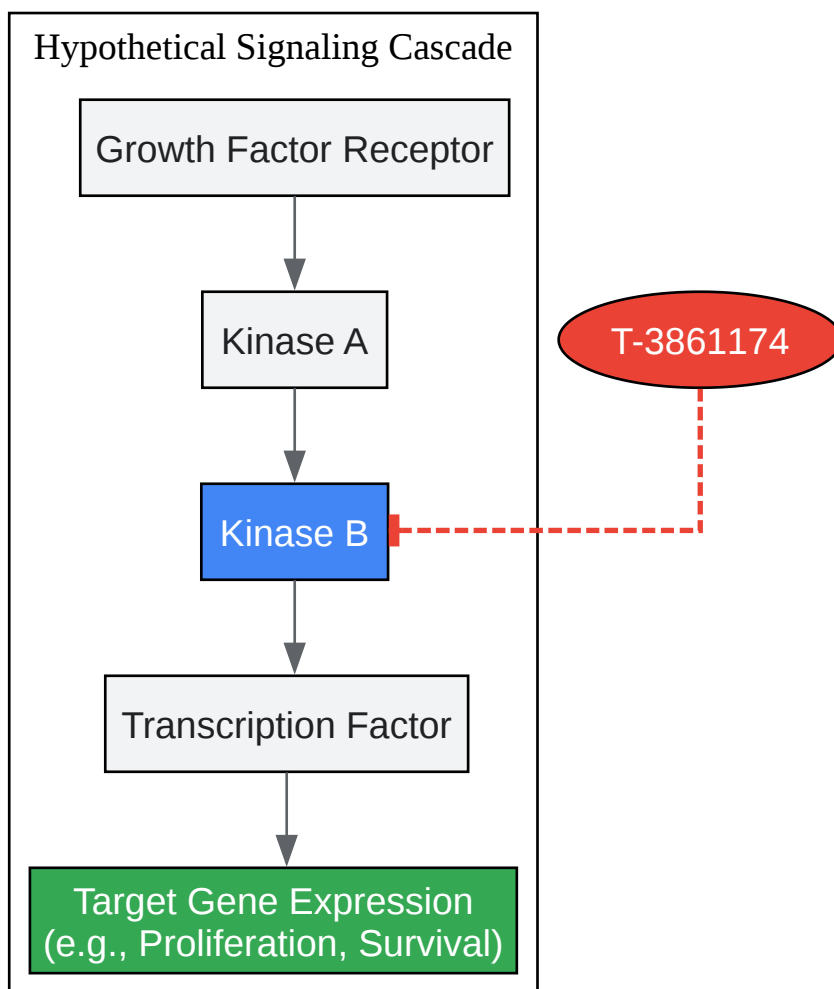

[Click to download full resolution via product page](#)

Caption: Hypothetical inhibition of Kinase B by **T-3861174**.

- To cite this document: BenchChem. [Technical Support Center: T-3861174 Dose-Response Curve Optimization]. BenchChem, [2026]. [Online PDF]. Available at: [\[https://www.benchchem.com/product/b14754603/docs#technical-support-center-t-3861174-dose-response-curve-optimization\]](https://www.benchchem.com/product/b14754603/docs#technical-support-center-t-3861174-dose-response-curve-optimization)

Disclaimer & Data Validity:

The information provided in this document is for Research Use Only (RUO) and is strictly not intended for diagnostic or therapeutic procedures. While BenchChem strives to provide

accurate protocols, we make no warranties, express or implied, regarding the fitness of this product for every specific experimental setup.

Technical Support: The protocols provided are for reference purposes. Unsure if this reagent suits your experiment?

Need Industrial/Bulk Grade? [Request Custom Synthesis Quote](#)

BenchChem

Our mission is to be the trusted global source of essential and advanced chemicals, empowering scientists and researchers to drive progress in science and industry.

Contact

Address: 3281 E Guasti Rd
Ontario, CA 91761, United States
Phone: (601) 213-4426
Email: info@benchchem.com

[Contact our Ph.D. Support Team for a compatibility check](#)