

Technical Support Center: Optimizing Yield for Propargyl Iodide Coupling Reactions

Author: BenchChem Technical Support Team. **Date:** April 2026

Compound of Interest

Compound Name: Propargyl iodide

CAS No.: 659-86-9

Cat. No.: B14754630

[Get Quote](#)

Welcome to the Technical Support Center for researchers, scientists, and drug development professionals. This resource provides comprehensive troubleshooting guides and frequently asked questions (FAQs) to help you optimize the yield of your **propargyl iodide** coupling reactions.

Frequently Asked Questions (FAQs) & Troubleshooting Guides

This section addresses specific issues you may encounter during your experiments in a question-and-answer format.

Sonogashira Coupling

Question 1: My Sonogashira reaction with **propargyl iodide** is giving a low or no yield. What are the common causes and how can I troubleshoot this?

Answer: Low or no yield in a Sonogashira coupling involving **propargyl iodide** is a common issue. A systematic approach to troubleshooting is crucial. Key factors to investigate include the

quality of your reagents, the reaction conditions, and the potential for side reactions.

Troubleshooting Steps:

- Reagent Quality:
 - **Propargyl iodide** Purity: **Propargyl iodide** can degrade over time, especially when exposed to light and air.[1] Use a fresh bottle or purify the reagent by distillation before use. Store it in a cool, dry, and dark place.[1][2]
 - Aryl Halide Reactivity: The reactivity of the aryl halide significantly impacts the reaction outcome. The general reactivity trend is $I > Br > Cl$. [3][4] For less reactive aryl halides (bromides and chlorides), higher temperatures and more active catalyst systems may be necessary.
 - Catalyst Activity: Ensure your palladium and copper catalysts are active. Palladium(0) species are prone to oxidation. Consider using a fresh batch of catalyst or a pre-catalyst that is activated in situ.
 - Solvent and Base Purity: Use anhydrous and degassed solvents to prevent quenching of the catalyst and reagents. The base should be of high purity and appropriate for the reaction.
- Reaction Conditions:
 - Inert Atmosphere: The Sonogashira coupling is sensitive to oxygen. Ensure your reaction is set up under an inert atmosphere (e.g., argon or nitrogen) and that all solvents and reagents are properly degassed.
 - Temperature: While some Sonogashira couplings proceed at room temperature, others may require heating.[3] However, excessive heat can lead to the decomposition of **propargyl iodide** and the catalyst. Optimization of the reaction temperature is key.
 - Base Selection: The choice of base is critical. Amine bases like triethylamine (NEt₃) or diisopropylethylamine (DIPEA) are commonly used. However, these can react with **propargyl iodide** in a competing S_N2 reaction.[5] If this is suspected, consider using a non-nucleophilic base.

- Side Reactions:
 - Homocoupling (Glaser Coupling): The formation of a di-yne byproduct from the self-coupling of the terminal alkyne is a common side reaction, especially in the presence of oxygen.[6] To minimize this, ensure a strictly anaerobic environment and consider using a copper-free Sonogashira protocol if homocoupling persists.
 - Decomposition of **Propargyl iodide**: **Propargyl iodide** is a reactive alkylating agent and can be consumed by side reactions with nucleophilic species in the reaction mixture.[5]

Cadiot-Chodkiewicz Coupling

Question 2: I am observing a significant amount of homocoupled byproduct in my Cadiot-Chodkiewicz reaction. How can I improve the selectivity for the cross-coupled product?

Answer: The formation of homocoupled diynes is a primary challenge in Cadiot-Chodkiewicz couplings. This side reaction occurs when the terminal alkyne couples with itself, catalyzed by the copper(I) salt.

Strategies to Minimize Homocoupling:

- Strictly Anaerobic Conditions: Oxygen promotes the oxidative homocoupling (Glaser coupling).[6] Ensure your reaction is thoroughly degassed and maintained under a positive pressure of an inert gas.
- Slow Addition of the Terminal Alkyne: Adding the terminal alkyne slowly to the reaction mixture containing the haloalkyne and the copper catalyst can help to maintain a low concentration of the terminal alkyne, thus disfavoring the homocoupling reaction.
- Use of a Co-solvent: The solubility of the reactants can influence the reaction rate and selectivity. Using a co-solvent like methanol, ethanol, DMF, or THF can improve the solubility of the alkyne and enhance the desired cross-coupling.[7]
- Ligand Addition: The addition of a ligand, such as a phosphine or a diamine, can modulate the reactivity of the copper catalyst and in some cases, improve the selectivity for the cross-coupling product.[7]

A3 Coupling (Aldehyde-Alkyne-Amine)

Question 3: My A3 coupling reaction to synthesize propargylamines is not proceeding to completion. What should I check?

Answer: The A3 coupling is a powerful one-pot reaction, but its efficiency can be affected by several factors.

Troubleshooting Checklist:

- **Catalyst Choice and Loading:** While copper salts are common, other metals like gold and silver can also be used.^[8] The catalyst loading is also important; typically 1-5 mol% is sufficient.
- **Imine/Iminium Ion Formation:** The reaction proceeds through the formation of an imine or iminium ion from the aldehyde and amine.^{[9][10]} Ensure that your aldehyde and amine are of good quality and that the reaction conditions are suitable for imine formation. The presence of a dehydrating agent can sometimes be beneficial.
- **Solvent Effects:** The choice of solvent can significantly impact the reaction rate and yield. While some A3 couplings can be performed neat, solvents like toluene, MeCN, or even water can be effective.^{[9][11]} The optimal solvent will depend on the specific substrates.
- **Acidity of the Alkyne C-H Bond:** The reaction involves the deprotonation of the terminal alkyne.^[9] If you are using a less acidic alkyne, a stronger base or more forcing conditions may be required.

Data Presentation

The following tables summarize typical reaction conditions and reported yields for various **propargyl iodide** coupling reactions. This data is intended to serve as a starting point for your own optimizations.

Table 1: Sonogashira Coupling of **Propargyl Iodide** with Aryl Halides

Entry	Aryl Halide	Catalyst System	Base	Solvent	Temp (°C)	Time (h)	Yield (%)	Reference
1	Iodobenzene	Pd(PPh ₃) ₄ / CuI	NEt ₃	THF	RT	4	85	N/A
2	4-Bromonitrobenzene	PdCl ₂ (PPh ₃) ₂ / CuI	Piperidine	DMF	80	6	78	N/A
3	4-Chlorotoluene	Pd(OAc) ₂ / XPhos / CuI	K ₂ CO ₃	Dioxane	100	12	65	N/A
4	1-Iodonaphthalene	Pd(dba) ₃ / P(t-Bu) ₃ / CuI	DBU	Acetonitrile	60	8	92	N/A

Note: Yields are highly substrate-dependent and the conditions listed are representative examples.

Table 2: Cadiot-Chodkiewicz Coupling of **Propargyl Iodide** with Terminal Alkynes

Entry	Terminal Alkyne	Catalyst	Base	Solvent	Temp (°C)	Time (h)	Yield (%)	Reference
1	Phenylacetylene	CuI	Piperidine	Methanol	RT	2	90	N/A
2	1-Hexyne	CuBr	n-Butylamine	Ethanol	RT	3	85	N/A
3	Trimethylsilylacetylene	CuCl	Diethylamine	THF	40	5	88	N/A
4	Propargyl alcohol	CuI	Hydroxylamine HCl / Et ₃ N	Water	50	4	75	N/A

Note: The haloalkyne in these examples would be prepared from **propargyl iodide**.

Table 3: A3 Coupling for Propargylamine Synthesis using **Propargyl Iodide** as the Alkyne Source

Entry	Aldehyde	Amine	Catalyst	Solvent	Temp (°C)	Time (h)	Yield (%)	Reference
1	Benzaldehyde	Piperidine	CuI	Toluene	80	4	92	[11]
2	4-Nitrobenzaldehyde	Morpholine	CuBr	MeCN	60	6	85	[11]
3	Cyclohexanecarboxaldehyde	Pyrrolidine	CuCl	Neat	100	2	88	[11]
4	Furfural	Diethylamine	AgOTf	Dioxane	80	5	95	N/A

Note: **Propargyl iodide** would first be converted to a terminal alkyne in situ or used in a subsequent step.

Experimental Protocols

Protocol 1: General Procedure for Sonogashira Coupling of an Aryl Iodide with a Terminal Alkyne

- To a flame-dried Schlenk flask under an inert atmosphere (argon or nitrogen), add the aryl iodide (1.0 mmol), Pd(PPh₃)₄ (0.02 mmol, 2 mol%), and CuI (0.04 mmol, 4 mol%).
- Add anhydrous, degassed solvent (e.g., THF or DMF, 5 mL).
- Add the terminal alkyne (1.2 mmol) followed by the amine base (e.g., triethylamine, 2.0 mmol).
- Stir the reaction mixture at the desired temperature (room temperature to 80 °C) and monitor the progress by TLC or GC/MS.

- Upon completion, cool the reaction to room temperature and dilute with an organic solvent (e.g., ethyl acetate).
- Filter the mixture through a pad of Celite to remove the catalyst.
- Wash the filtrate with saturated aqueous NH_4Cl solution and then with brine.
- Dry the organic layer over anhydrous Na_2SO_4 , filter, and concentrate under reduced pressure.
- Purify the crude product by column chromatography on silica gel.

Protocol 2: General Procedure for Cadiot-Chodkiewicz Coupling

- To a round-bottom flask under an inert atmosphere, add the 1-haloalkyne (1.0 mmol), CuI (0.05 mmol, 5 mol%), and a solvent such as methanol or ethanol (10 mL).
- Add an amine base (e.g., piperidine or n-butylamine, 2.0 mmol) and hydroxylamine hydrochloride (0.1 mmol, 10 mol%) as a reducing agent to maintain the Cu(I) state.
- Add the terminal alkyne (1.1 mmol) dropwise to the reaction mixture at room temperature.
- Stir the reaction at room temperature and monitor its progress by TLC.
- Once the reaction is complete, quench with a saturated aqueous solution of NH_4Cl .
- Extract the product with an organic solvent (e.g., diethyl ether or ethyl acetate).
- Wash the combined organic layers with water and brine, then dry over anhydrous MgSO_4 .
- Filter and concentrate the solvent under reduced pressure.
- Purify the product by column chromatography.

Protocol 3: General Procedure for A3 Coupling

- In a sealed tube, combine the aldehyde (1.0 mmol), amine (1.2 mmol), and terminal alkyne (1.5 mmol).
- Add the catalyst (e.g., CuI, 0.05 mmol, 5 mol%) and a solvent if required (e.g., toluene, 5 mL).
- Seal the tube and heat the reaction mixture to the desired temperature (e.g., 80-100 °C) with stirring.
- Monitor the reaction by TLC.
- After completion, cool the reaction to room temperature.
- Dilute the reaction mixture with an organic solvent and wash with water.
- Separate the organic layer, and extract the aqueous layer with the same organic solvent.
- Combine the organic layers, dry over anhydrous Na₂SO₄, filter, and concentrate.
- Purify the crude propargylamine by column chromatography.[\[11\]](#)

Mandatory Visualizations

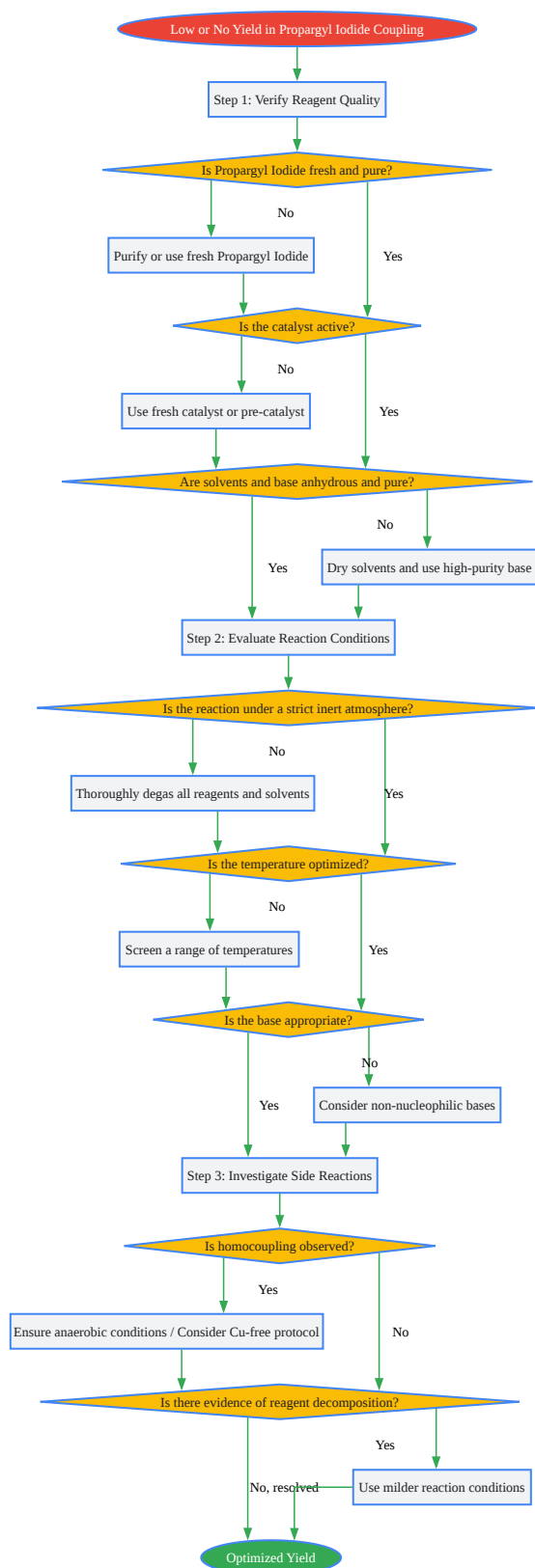

[Click to download full resolution via product page](#)

Caption: Troubleshooting workflow for low yield in **propargyl iodide** coupling reactions.

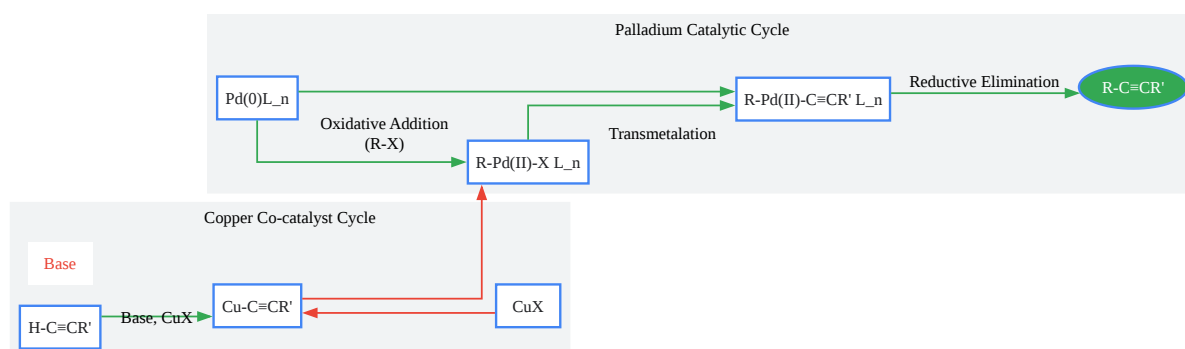

[Click to download full resolution via product page](#)

Caption: Simplified mechanism of the Sonogashira coupling reaction.

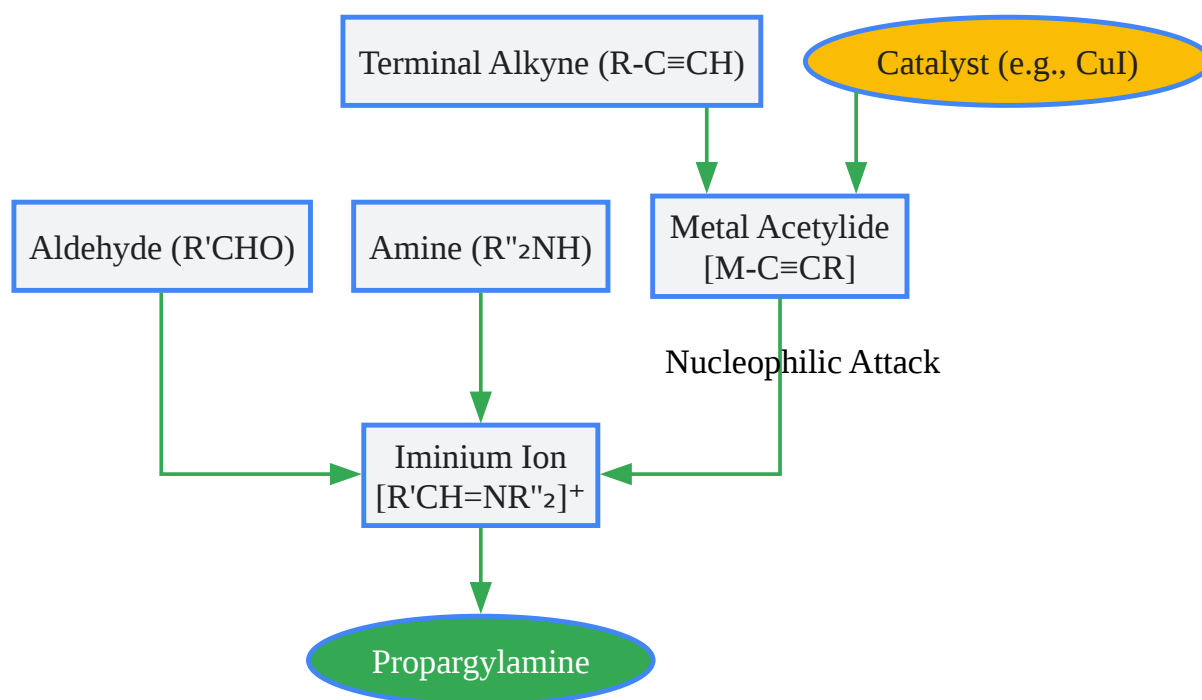

[Click to download full resolution via product page](#)

Caption: Key steps in the A3 coupling reaction mechanism.

Need Custom Synthesis?

BenchChem offers custom synthesis for rare earth carbides and specific isotopic labeling.

Email: info@benchchem.com or [Request Quote Online](#).

References

- 1. [sigmaaldrich.com](https://www.sigmaaldrich.com) [sigmaaldrich.com]
- 2. [echemi.com](https://www.echemi.com) [echemi.com]
- 3. [Sonogashira Coupling | NROChemistry](https://www.nrochemistry.com) [nrochemistry.com]
- 4. [Sonogashira coupling - Wikipedia](https://en.wikipedia.org) [en.wikipedia.org]
- 5. [researchgate.net](https://www.researchgate.net) [researchgate.net]
- 6. [benchchem.com](https://www.benchchem.com) [benchchem.com]

- [7. pubs.rsc.org \[pubs.rsc.org\]](https://pubs.rsc.org)
- [8. researchgate.net \[researchgate.net\]](https://researchgate.net)
- [9. chem.libretexts.org \[chem.libretexts.org\]](https://chem.libretexts.org)
- [10. phytojournal.com \[phytojournal.com\]](https://phytojournal.com)
- [11. researchgate.net \[researchgate.net\]](https://researchgate.net)
- To cite this document: BenchChem. [Technical Support Center: Optimizing Yield for Propargyl Iodide Coupling Reactions]. BenchChem, [2026]. [Online PDF]. Available at: [<https://www.benchchem.com/product/b14754630/docs#technical-support-center-optimizing-yield-for-propargyl-iodide-coupling-reactions>]

Disclaimer & Data Validity:

The information provided in this document is for Research Use Only (RUO) and is strictly not intended for diagnostic or therapeutic procedures. While BenchChem strives to provide accurate protocols, we make no warranties, express or implied, regarding the fitness of this product for every specific experimental setup.

Technical Support: The protocols provided are for reference purposes. Unsure if this reagent suits your experiment?

Need Industrial/Bulk Grade? [Request Custom Synthesis Quote](#)

BenchChem

Our mission is to be the trusted global source of essential and advanced chemicals, empowering scientists and researchers to drive progress in science and industry.

Contact

Address: 3281 E Guasti Rd

Ontario, CA 91761, United States

Phone: (601) 213-4426

Email: info@benchchem.com

Contact our Ph.D. Support Team for a compatibility check