

AF568 NHS Ester: A Comprehensive Technical Guide for Bioconjugation

Author: BenchChem Technical Support Team. **Date:** May 2026

Compound of Interest

Compound Name: AF568 NHS ester

Cat. No.: B14754393

[Get Quote](#)

For Researchers, Scientists, and Drug Development Professionals

This in-depth guide serves as a technical resource for the effective use of **AF568 NHS ester** in bioconjugation. As a Senior Application Scientist, this guide is structured to provide not just protocols, but the scientific reasoning behind them, ensuring robust and reproducible results. We will cover the fundamental properties, safety protocols, and detailed experimental workflows for this versatile fluorescent label.

Core Properties and Chemical Identity

AF568 NHS ester, also known as Alexa Fluor™ 568 NHS Ester, is a bright, orange-fluorescent dye widely utilized for labeling primary amines in proteins, antibodies, and other biomolecules. [1] Its N-hydroxysuccinimidyl (NHS) ester functional group allows for efficient and specific covalent attachment to primary amines (-NH₂) on lysine residues and the N-terminus of proteins, forming a stable amide bond. [2][3][4]

Property	Value
CAS Number	247145-38-6[5]
Molecular Weight	~791.8 g/mol [2][5][6]
Excitation Maximum	578 nm[3][6][7]
Emission Maximum	602-603 nm[1][3][6][7]
Extinction Coefficient	~88,000-91,000 cm ⁻¹ M ⁻¹ [6]
Appearance	Solid[2][5]
Solubility	DMSO, DMF[2][5]

The fluorophore is water-soluble and its fluorescence is pH-insensitive between pH 4 and 10, making it suitable for a wide range of biological applications.[2][5][8]

The Labeling Reaction: A Mechanistic Overview

The core of the labeling process is the reaction between the NHS ester and a primary amine, a classic example of nucleophilic acyl substitution.[9] The unprotonated primary amine acts as a nucleophile, attacking the carbonyl carbon of the NHS ester. This forms a transient tetrahedral intermediate that then collapses, releasing the N-hydroxysuccinimide (NHS) leaving group and forming a stable amide bond.[9][10]

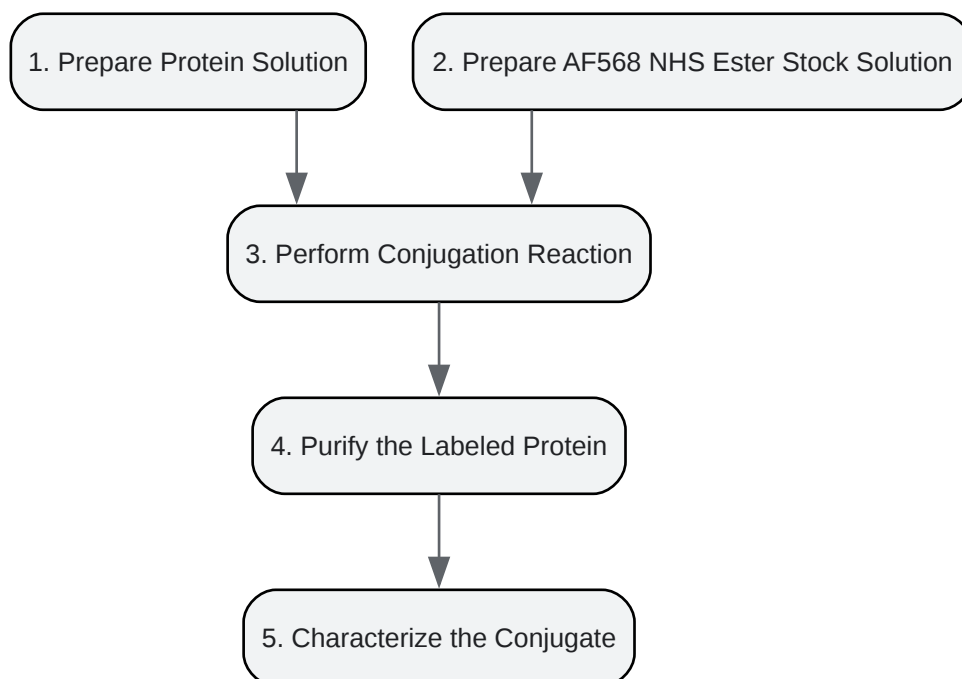
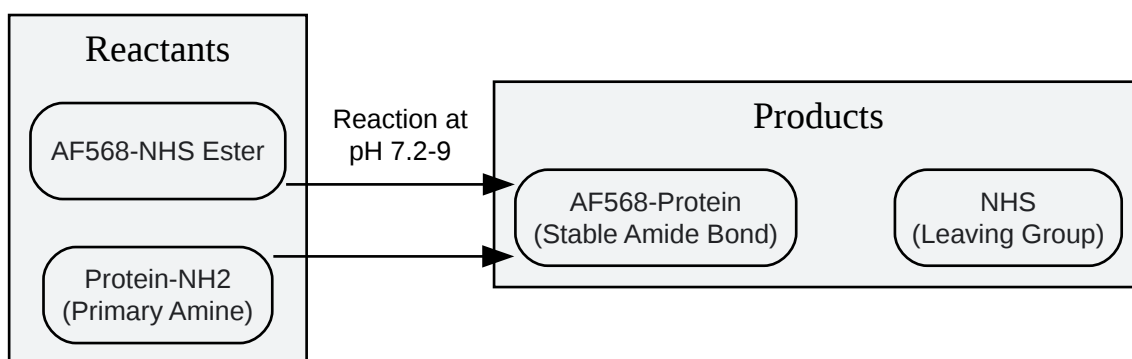

[Click to download full resolution via product page](#)

Need Custom Synthesis?

BenchChem offers custom synthesis for rare earth carbides and specific isotopic labeling.

Email: info@benchchem.com or [Request Quote Online](#).

Sources

- [1. medchemexpress.com \[medchemexpress.com\]](https://www.medchemexpress.com)
- [2. docs.aatbio.com \[docs.aatbio.com\]](https://docs.aatbio.com)

- [3. abpbio.com \[abpbio.com\]](#)
- [4. documents.thermofisher.com \[documents.thermofisher.com\]](#)
- [5. AF568 NHS 酯 / Alexa Fluor 568 NHS Ester\(Succinimidyl Ester\) -结构一致 CAS : 247145-38-6-陕西金杰森茂生物科技有限公司-官网 \[geneschem.com\]](#)
- [6. Invitrogen Alexa Fluor 568 NHS Ester \(Succinimidyl Ester\) 5 mg | Buy Online | Invitrogen™ | Fisher Scientific \[fishersci.fi\]](#)
- [7. FluoroFinder \[app.fluorofinder.com\]](#)
- [8. vectorlabs.com \[vectorlabs.com\]](#)
- [9. pdf.benchchem.com \[pdf.benchchem.com\]](#)
- [10. glenresearch.com \[glenresearch.com\]](#)
- [To cite this document: BenchChem. \[AF568 NHS Ester: A Comprehensive Technical Guide for Bioconjugation\]. BenchChem, \[2026\]. \[Online PDF\]. Available at: \[https://www.benchchem.com/product/b14754393/docs#af568-nhs-ester-a-comprehensive-technical-guide-for-bioconjugation\]](#)

Disclaimer & Data Validity:

The information provided in this document is for Research Use Only (RUO) and is strictly not intended for diagnostic or therapeutic procedures. While BenchChem strives to provide accurate protocols, we make no warranties, express or implied, regarding the fitness of this product for every specific experimental setup.

Technical Support: The protocols provided are for reference purposes. Unsure if this reagent suits your experiment?

Need Industrial/Bulk Grade? [Request Custom Synthesis Quote](#)

BenchChem

Our mission is to be the trusted global source of essential and advanced chemicals, empowering scientists and researchers to drive progress in science and industry.

Contact

Address: 3281 E Guasti Rd
Ontario, CA 91761, United States
Phone: (601) 213-4426
Email: info@benchchem.com

Contact our Ph.D. Support Team for a compatibility check